

Unit / Module Name:	Dual channel 14-bit DAC – 840 MSPS
Unit / Module Number:	SMT381
Used On:	SMT338-VP, SMT320, SMT310Q, SMT327, SMT300Q
Document Issue:	1.6.0
Date:	23/09/2004

CONFIDENTIAL

Approvals		Date
Managing Director		
Software Manager		
Design Engineer		

Sundance Multiprocessor Technology Ltd, Chiltern House, Waterside, Chesham, Bucks. HP5 1PS.
This documents is the property of Sundance and may not be copied nor communicated to a third party
without the written permission of Sundance. © Sundance Multiprocessor Technology Limited 1999



Certificate Number FM 55022

Revision History

	Changes Made	Issue	Initials
01/06/04	First release	1.0.0	LPS
28/06/04	Updated analog output circuit and PCB placement	1.1.0	LPS
15/07/04	General Updated to Document	1.2.0	LPS
16/07/04	Updated ext clock input description and updated part descriptions	1.3.0	LPS
11/08/04	Added figure indicating test points on SMT381	1.4.0	LPS
20/09/04	General Updates to Document	1.5.0	MRV
23/09/04	Added waveform performance specifications	1.6.0	MRV

List of Abbreviations

Abbreviation	Explanation
ATP	Acceptance Test Procedure
BCD	Binary Coded Decimal
BER	Bit Error Rate
BOM	Bill Of Materials
CDR	Clock and Data Recovery
CPCI	Compact PCI
DAC	Digital to Analog Converter
DDR	Double Data Rate
DLL	Delay Lock Loop
DSP	Digital Signal Processor
FPGA	Field Programmable Gate Array
GSPS	Giga Sample Per Second
LSB	Least Significant Bit
LVDS	Low Voltage Differential Signalling
LVPECL	Low Voltage Positive ECL
MSB	Most Significant Bit
NA	Not Applicable
PC	Personal Computer
PCB	Printed Circuit Board
PCI	Peripheral Component Interconnect
POR	Power On Reset
RSL	Rocket Serial Link
RSLCC	Rocket Serial Link Communications Channel
SDRAM	Synchronous Dynamic Random Access Memory
SHB	Sundance High-speed Bus
SI	Serial Interface
SMT	Sundance Multiprocessor Technology
SPI	Serial Peripheral Interface
TBD	To Be Determined
TI	Texas Instruments
VCO	Voltage Controlled Oscillator

Table of Contents

1	Introduction	10
1.1	Overview	10
1.2	Module Features.....	10
1.3	Possible Applications.....	10
1.4	Related Documents	11
2	Functional Description.....	12
2.1	Module Overview.....	12
2.2	Communication Ports (ComPorts)	13
2.3	Sundance High-Speed Bus (SHB).....	13
2.4	Main Analogue characteristics	14
2.5	Data stream description.....	14
2.5.1	Description of internal FPGA blocks	15
2.6	Clock Structure	17
2.7	Trigger Structure.....	18
2.8	Power Supply and Reset Structure.....	19
2.9	MSP430 Functionality.....	20
2.10	FPGA Configuration.....	22
2.11	Analogue output section	22
2.12	DAC Settings.....	24
3	Description of interfaces.....	24
3.1	DAC Control Interface.....	24
3.2	DAC Data Interface	25
3.3	Memory Interface.....	25
3.4	MSP430 Interface.....	25
3.5	Serial Number	25
3.6	PLL Interface	25
3.7	Clock Synthesizer Interface	26
3.8	TIM Interface	26
3.9	External Trigger	26
3.10	Daughter card Interface	26
3.11	RSL Interface (RSL not yet available).....	33
3.11.1	RSL Connector and Pinout Definition	33
3.11.2	RSL Cable Definition	35
3.12	SHB Interface	35
4	Firmware Description	39
4.1	Main States	39
4.2	Configuring the FPGA.....	40
4.3	Setting up the FPGA.....	40
5	Control Register Settings	41
5.1	Control Packet Structure.....	41
5.2	Reading and Writing Registers	42
5.3	Memory Map	43
5.4	Register Descriptions.....	45

5.4.1 The Reset Register	45
5.4.2 Firmware Version Register (Read Add 0x000)	45
5.4.3 Temperature Registers (Read Add 0x020, 0x021, 0x028,0x029)	46
5.4.4 Serial Number Registers (Read Add 0x022 – 0x025 and 0x02A – 0x02D)	46
5.4.5 DAC Clock Source Registers (Write Add 0x801)	47
5.4.6 Clock Synthesizer Setup Register (Write Add 0x800).....	47
5.4.7 PLL Setup Registers (Write Add 0x802 – 0x809)	48
5.4.8 DAC Setup Registers (Write Add 0x900 – 0x905)	48
6 PCB Layout.....	50
6.1 SMT381 PCB View.....	50
6.2 Assembly Drawings	51
6.3 SMT338-VP Assembly Drawings.....	53
6.4 SMT381 PCB View.....	54
7 General Properties.....	58
7.1 FPGA Mounted on SMT338-VP.....	58
7.2 Design Resource Usage.....	58
7.3 Power Supply	58
7.4 Module Dimensions	59
7.5 FPGA/JTAG Connector	60
8 System Setup.....	61
8.1 How to connect the SMT381 to SMT338-VP	61
9 Module Performance.....	65
9.1 Introduction.....	65
9.2 LVDS Data interface.....	65
9.3 Waveform Memory	66
10 Firmware Building Blocks.....	70
10.1 Introduction.....	70
10.2 Clock Synthesizer.....	70
10.3 DAC serial setup.....	71
10.4 PLL Configuration.....	74
11 Test Points.....	77
12 APPENDIX A – Waveform Memory Setup	78
12.1 Introduction.....	78
10.2 System Setup	78
10.2 Software Setup.....	78

Table of Tables

Table 1. Main analogue characteristics of the SMT381.	14
Table 2. Daughter Card Interface Power Connector and Pinout.	29
Table 3. Register Memory Map (DAC registers not yet fixed in firmware).....	45
Table 4. Table of Connector Locations on SMT381.	56
Table 5. Table of Component Locations on SMT381.....	57
Table 6. Virtex-II Pro IO Count.	58
Table 7. Virtex-II Pro Device Utilization Summary.	58
Table 8. SMT381 Power Supply Voltages.	59
Table 9. SMT381-VP Power Supply Voltages.	59
Table 10. Internal Power Supply Voltages.....	59
Table 11. SMT381-VP Dimensions.	60
Table 12. Clock Synthesizer Test Output.	70
Table 13. Clock Synthesizer Division Setup.	71
Table 14. Configuration of the DACSerialSetupReg register.	73

Table of Figures

Figure 1. Functional Block diagram of SMT381.....	12
Figure 2. Internal Data path of the SMT338-VP.....	15
Figure 3. Clock tree of the SMT381.....	17
Figure 4. Trigger structure of the SMT381 and SMT338-VP.....	19
Figure 5. Power Generation and distribution.	20
Figure 6. Microcontroller State Machine.	21
Figure 7. Option 1 for the SMT381 analog output stage.	23
Figure 8. Option 2 for the SMT381 analog output stage.	23
Figure 9. Combined analog output circuit.	24
Figure 10. Daughter card connector interface	27
Figure 11. Daughter Card Interface: Data Signals Connector and Pinout (Bank A).	30
Figure 12. Daughter Card Interface: Data Signals Connector and Pinout (Bank B).	31
Figure 13. Daughter Card Interface: Data Signals Connector and Pinout (Bank C).	32
Figure 14. Rocket Serial Link Interface.	33
Figure 15. Rocket Serial Link Interface Connector and Pinout (RSL A).	34
Figure 16. Rocket Serial Link Interface Connector and Pinout (RSL B).	35
Figure 17. Samtec HFEM Series Data Cable.	35
Figure 18. Possible SHB Configurations.	36
Figure 19. SHB Connector Configuration 1 Pinout.	37
Figure 20. SHB Connector Configuration 2 Pinout.	38
Figure 21. SMT381-VP Firmware State Diagram.	39
Figure 22. Setup Packet Structure.	41
Figure 23. Packet Structure – Defined Commands.	42
Figure 24. Control Register Read Sequence.	42
Figure 25. Reset Register (Write Only).....	45
Figure 26. Firmware Version Register (Read Only).....	45
Figure 27. Temperature Registers (Read Only).....	46
Figure 28. Serial Number Registers (Read Only).	46
Figure 29. Serial Number Registers Cont. (Read Only).....	47
Figure 30. Clock Source Selection Table (Write Only).....	47
Figure 31. Clock Source Register (Write Only).....	47
Figure 32. Clock Synthesizer Setup Register (Write Only).	47
Figure 33. PLL Setup Registers (Write Only).	48
Figure 34. DAC Setup Registers (Write Only).	48
Figure 35. SMT 381 PCB layout - TOP.	50
Figure 36. SMT 381 PCB layout – BOTTOM.....	50
Figure 37. SMT381 Top Assembly Drawings.	51
Figure 38. SMT381 Bottom Assembly Drawings.	51
Figure 39. Main Module Top Assembly Drawing.	53
Figure 40. Main Module Bottom Assembly Drawing.	54
Figure 41. Side view of SMT381-VP (Height).....	54
Figure 42. Side view of SMT381-VP.	55
Figure 43. Top view of SMT381-VP.	55

Figure 44. Connector Location on SMT381,	56
Figure 45. FPGA/JTAG connector for the SMT381-VP.	60
Figure 46. SMT381 to SMT338-VP Interconnection.	61
Figure 47. Components Used to Connect the SMT381 to the SMT338-VP.	62
Figure 48. Fitting of Nylon Screws and Nuts to the SMT338-VP.	63
Figure 49. Securing the SMT338-VP onto a Sundance Carrier.	63
Figure 50. Connecting the SMT381 to the SMT338-VP.....	64
Figure 51. Time View Captures of LVDS Interface Data.....	65
Figure 52. Measurements of Time View Capture.	65
Figure 53. Waveform Memory - Time View Capture – 1000MHz sample frequency (500MHz VCO Clock) – 125MHz analog output.	66
Figure 54. Measurements of Capture – 1000MHz sample frequency (500MHz VCO Clock) – 125MHz analog output.	66
Figure 55. Waveform Memory - FFT – 1000MHz sample frequency (500MHz VCO Clock) – 125MHz analog output – Channel A.....	67
Figure 56. Waveform Memory - FFT – 1000MHz sample frequency (500MHz VCO Clock) – 125MHz analog output – Channel B.....	67
Figure 57. Waveform Memory - FFT – 1400MHz sample frequency (700MHz Synthesizer Clock) – 175MHz analog output – Channel A.	68
Figure 58. Waveform Memory - FFT – 1400MHz sample frequency (700MHz Synthesizer Clock) – 175MHz analog output – Channel B.	68
Figure 59. Waveform Memory - FFT – 600MHz sample frequency (300MHz VCO Clock) – 75MHz analog output – Channel A.....	69
Figure 60. Waveform Memory - FFT – 600MHz sample frequency (300MHz VCO Clock) – 75MHz analog output – Channel B.....	69
Figure 61. Clock Synthesizer Register.	70
Figure 62. Clock Synthesizer Frequency Calculation.	71
Figure 63. DAC serial write operation.....	72
Figure 64. DAC serial read operation.	72
Figure 65. State machine of the DAC for the SMT381.....	73
Figure 66. Register Setup for PLL.....	74
Figure 67. PLL Configuration Sequence.....	75
Figure 68. State Machine Driving the PLL Serial Interface.	76
Figure 69. Test point locations on the SMT381.	77
Figure 70. Test Program Main Menu.	78
Figure 71. SMT338-VP Sub-Menu.	79
Figure 72. SMT381 Sub-Menu.	80
Figure 73. Waveform Memory Setup Sequence.....	81

Precautions (Please Read this!).

In order to guarantee that the *SMT381-VP* functions correctly and to protect the module from damage, the following precautions should be taken:

The *SMT381-VP* is a static sensitive product and should be handled accordingly. Always place the module in a static protective bag during storage and transition.

When operated, make sure that the heat generated by the system is extracted e.g. by the use of a fan extractor or an air blower.

SHB and RSL connectors are similar but their use is really different. Do NOT connect an SHB and an RSL connectors together with an SHB cable! This would cause irreversible damages to the modules.

Naming Conventions.

The SMT381 refers to a dual channel, 14-bit, 840MSPS DAC daughter card.

The SMT338-VP refers to a single width Virtex-II Pro based FPGA module with a Sundance LVDS Bus interface (used for connecting TIM modules to daughter cards)

The SMT381-VP refers to the SMT381 plugged onto the SMT338-VP forming a complete module DAC + FPGA Module.

1 Introduction

1.1 Overview

The *SMT381-VP* is a single width expansion module that plugs onto the *SMT338-VP*. It is capable of converting two external digital inputs coming from the *SMT338-VP* at 840 MSPS with a resolution of 14 bits, or from internal memory at 1GSPS. A Fujitsu dual channel DAC ([MB86064](#)) performs the digital to analogue conversion.

The *SMT381* (daughter card) is plugged into the *SMT338-VP* (main module). Digital data is then supplied from the *SMT338-VP* via the *daughter card connector* over the [Sundance LVDS Bus](#) to the *SMT381* which converts the digital data stream to an analogue signal.

The *SMT338-VP* controls data transfers via ComPorts, **Sundance High-speed Bus** ([SHB](#)) or the **Rocket Serial Link** (RSL) (The RSL interface is not yet implemented). These interfaces are compatible with a wide range of Sundance processor and I/O modules.

A very important aspect must be kept in mind by the user. The DAC is rated for 1 GSPS but the *SMT338-VP*'s FPGA can only supply data to the DAC at 840MHz. It is however possible to load data into the onboard memory on the DAC. This internal data can be converted at 1GSPS.

1.2 Module Features

The main features of the *SMT381* are listed underneath:

- Dual channel DAC
- 1 GSPS conversion frequency from internal memory
- 840MSPS conversion frequency for data coming from the *SMT338-VP*
- 14 Bit data resolution
- Custom Clock and Trigger inputs via external connectors
- Internal Waveform generator
- Standard Sundance ComPorts and SHB interfaces for easy interconnection to Sundance products (interfaces for data sample and non-real-time processing)

1.3 Possible Applications

The *SMT381-VP* can be used for the following applications (this non-exhaustive list should be taken as an example):

- Broadband cable modem head-end systems
- 3G Radio transceivers
- High-data-rate point-to-point radios
- Medical imaging systems
- Spectrum analyzers

1.4 Related Documents

[1] Sundance High-speed Bus (*SHB*) specifications – Sundance.

ftp://ftp2.sundance.com/Pub/documentation/pdf-files/SHB_Technical_Specification_v1_0.pdf

[2] RocketIO Serial Links (*RSL*) specifications – Sundance.

ftp://ftp2.sundance.com/Pub/documentation/pdf-files/RSL_Technical_Specification_v1_0.pdf

[3] **TIM** specifications.

ftp://ftp2.sundance.com/Pub/documentation/pdf-files/tim_spec_v1.01.pdf

[4] Sundance LVDS Bus (*SLB*) specifications – Sundance.

<http://www.sundance.com/docs/SLB%20-%20Technical%20Specifications.pdf>

[5] Virtex-II Pro FPGA datasheet - Xilinx.

<http://direct.xilinx.com/bvdocs/publications/ds083.pdf>

[6] Fujitsu MB86064 DAC datasheet.

<http://www.fme.fujitsu.com>

[7] ComPort specification – Texas Instruments.

<http://focus.ti.com/lit/ug/spru63c.pdf>

2 Functional Description

2.1 Module Overview

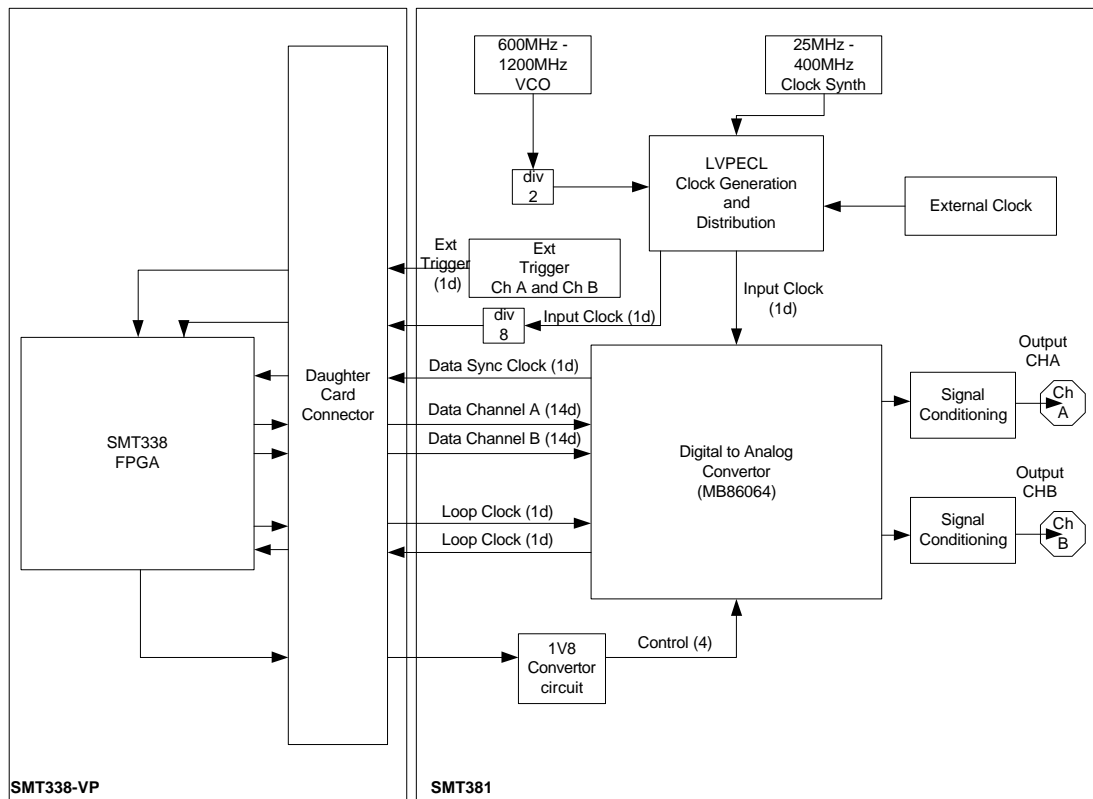

Notes: The numbers in brackets denote the amount of FPGA IO pins requires. 'd' is used for differential pairs. 1d Will thus require 2 IOs

Figure 1. Functional Block diagram of SMT381.

The *SMT338-VP* sends the digital data to the module via the *daughter card connector*. Data is clocked out of the FPGA on both edges of the DAC clock (DDR). The user can provide this clock by means of the VCO, Clock synthesizer or custom external clock. The external clock can be provided as an LVPECL clock or as an RF clock (two separate inputs).

All digital functions on the module are controlled by the *SMT338-VP*. There are two 14-bit LVDS ports on the DAC which converts the data on a DDR clock. The sampled data can either be supplied to the DAC cores externally via the LVDS data bus or internally from the Waveform Memory Module. The data may be routed to the DAC cores through a number of paths. The most direct path routes data straight from the LVDS input buffers to the DAC core input latches.

There are two DAC cores present in the MB86064. Thus two channels are available for outputs. The outputs of the DAC are differential currents, which are converted to a voltage by the analogue output stage. Details on the set up will be discussed later.

The design of the SMT381 is split over two PCBs. The main PCB (main module – SMT338-VP) contains the FPGA and the digital connector interfaces (TIM, SHB and

RSL). The main memory as well as the MSP430 microprocessor is also located on this PCB. The second PCB (daughter card – SMT381) contains all the analog circuitry. The clock generation, trigger control, analog signal conditioning and DAC is located on this PCB. The SMT381-VP refers to the combination of the SMT338-VP and the SMT381.

The depth of the SMT381-VP is 21 mm. If the SMT381-VP is mated with a PCI carrier two PCI slots will be required for the Module + Carrier combination. If the SMT381-VP is mated with a cPCI carrier the Module + Carrier will require two cPCI slots.

The FPGA gets control words over a ComPort interface following the Texas Instruments [C4x ComPort standard](#). The FPGA receives data through the onboard memory or SHB interface. It is then sent to the DAC cores over two 14-bit LVDS busses according to the [SLB](#) standard. The DACs convert the data and sends the data to the output connectors.

Two full (60-pin) SHB connectors are accessible from the FPGA. Their main function is to receive digital samples from other modules. Please refer to the [SHB specification](#) for more details about the way connectors can be configured.

A global reset signal is mapped to the FPGA from the bottom TIM connector via the MSP430 microcontroller.

2.2 Communication Ports (ComPorts)

The SMT381-VP provides two ComPorts – ComPort 0 and ComPort 3. Both of these ComPorts are connected to the FPGA on the SMT338-VP. ComPort 3 is also connected to the MSP430 microprocessor. The microprocessor is the master of this ComPort after reset and configures the FPGA with configuration data received over this link. After configuration the microprocessor releases the ComPort to the FPGA. These ComPorts are driven at 3.3V levels.

2.3 Sundance High-Speed Bus (SHB)

Two SHB connectors are used to transmit data to the SMT381-VP from the external world. Both SHB busses are identical and 60-bits wide. See the [SHB specification](#) for more information.

2.4 Main Analogue characteristics

The main analogue characteristics are listed in the following table:

Analogue outputs	
Output current range	20mA
Data Format	Analogue current
External sampling clock inputs (The clock frequency is divided by 2 on the SMT381 for a DDR clock for the DAC)	
LVPECL Clock	
Signal format	LVPECL
Frequency range	25MHz to 1000 MHz
RF Clock	
Signal format	Sinus wave
Frequency range	25MHz to 1000 MHz
Amplitude	0dBm Typ
External trigger inputs	
Signal format	LVPECL
Frequency range	DC to 100 MHz
ADC Performance @ Single tone at -1dBFS, 800MSa/s, DC to 400MHz (From DAC datasheet)	
Spurious Free Dynamic Range (SFDR) @ 20MHz	75dBc
Spurious Free Dynamic Range (SFDR) @ 300MHz	58dBc
Cross-talk 4 tone test, each tone at -15dBFS, centred at 276MHz	67dBc

Table 1. Main analogue characteristics of the SMT381.

2.5 Data stream description

The data paths for both channels on the module are the same. The DAC is driven by a single clock either generated on the module or provided by the user through an MMBX connector. As only a single clock is present on the module the two data-paths will always be in exact synchronization. As the data path on this module finds its origin in the *SMT338-VP*'s FPGA the internal data path of the FPGA must also be explained. Figure 2 shows the *SMT338-VP*'s FPGA data path.

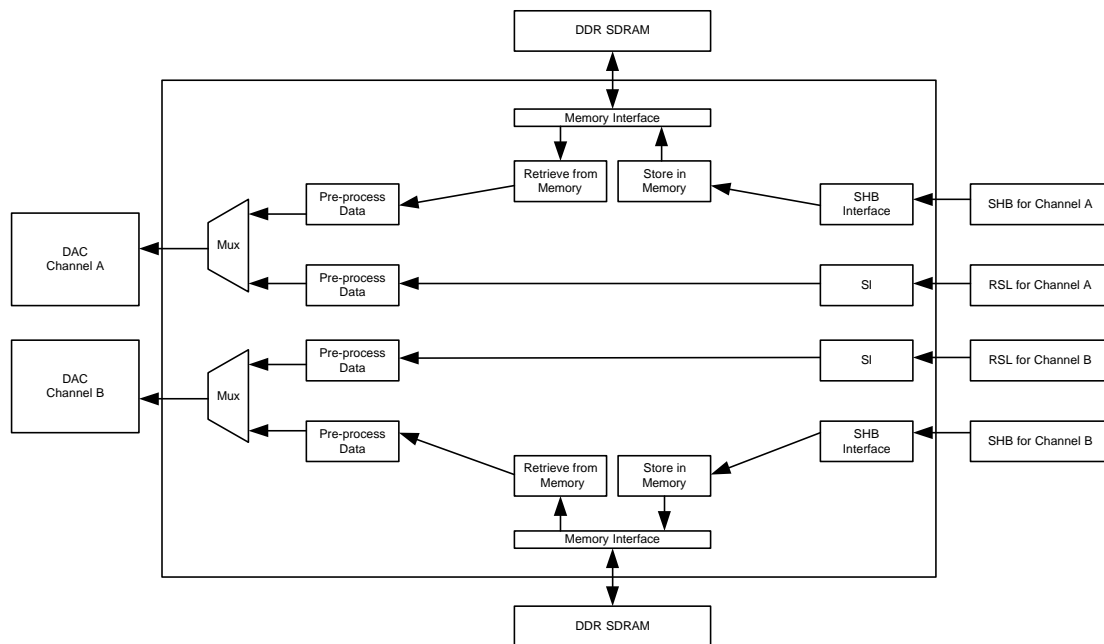

Figure 2. Internal Data path of the SMT338-VP.

The digital data stream is received from two interfaces. The first data stream is a direct RSL interface for real-time type applications (RSL is not yet implemented). While the second stream comes from the DDR SDRAM memory for non-real-time type module transmits (the memory is initialized over the SHB interface).

Each data stream is then conditioned and sent to the *SMT381* via the daughter card connector. A multiplexer selects between the two data streams.

2.5.1 Description of internal FPGA blocks

Pre-processing Data

The user can implement his own type of processing on the data stream if required.

SI

The Serial Interface block takes the high-speed serial input data stream and converts it into a parallel data stream (Not yet implemented).

Mux

The multiplexer connected to the RSL and SHB/memory interfaces selects between these two data streams to send to the *SMT381*.

Store in Memory

The store in memory block takes the incoming data stream from the SHB and stores the data into DDR SDRAM. This block will only transfer data from the memory to the *SMT381* when a valid trigger command is received. The amount of data that must be stored is configurable.

Memory Interface

The memory interface block is the DDR SDRAM controller. This block is responsible to all write and read transactions to and from the DDR SDRAM.

Retrieve from Memory

The retrieve from memory block retrieves stored data in the DDR SDRAM when it receives a valid read command. The read command specifies the location and amount of data that needs to be retrieved.

SHB Interface

The data received from the SHB interface is stored in memory. The SHB interface controls the SHB bus between the *SMT338-VP* and any module connected to the SHB sending the data.

In addition to the above interface blocks the FPGA also implements the following functions (not indicated on the diagram):

Trigger Interface

Handles all triggers. Triggers may be received from the external hardware trigger connectors (two separate triggers – one for each channel), or by receiving a trigger command over the ComPort (also separate commands for each channel). When a trigger is received data is sent to the SMT381 from the memory on the SMT338-VP.

DAC Control Interface

Control interface for writing setup information to the DAC on the SMT381 to configure it for any selected mode of operation. Data is received over the ComPort interface and written out to the DAC over a serial interface.

Clock Synthesizer Interface

Control interface for writing setup information to the clock synthesizer on the SMT381 to configure its clock output frequency. Data is received over the ComPort interface and written out to the clock synthesizer over a serial interface.

PLL Interface

Control interface for writing setup information to the PLL on the SMT381 to configure the VCO output voltage. Data is received over the ComPort interface and written out to the PLL over a serial interface. The PLL drives one VCO circuit. This VCO + PLL circuit generates the main system clock and is configurable between 600 and 1200 MHz. The side is called the RF side. This clock is then divided by two which enables the DAC to have a very stable PLL + VCO clock ranging from 300 to 600MHz.

DAC Interface

The DAC interface sends a high speed data stream from the FPGA to the DAC present on the SMT381. There are two channels available on the DAC and data is latched into the DAC on the rising and falling edge (DDR) of the DAC's input clock which is clocked into the FPGA to make data synchronization easier. The inputs are 14bit data streams which is clocked out of the FPGA at a maximum frequency of 420MHz (on both edges, thus 840MSPS).

Clock Tree Setup Interface

There are various clock routing configurations available for the SMT381. This interface configures the clock tree.

2.6 Clock Structure

There are two integrated clock generators on the module. The user can either use these clocks or provide the module with an external clock (input via MMBX connectors). The following figure shows the *SMT381* clock tree.

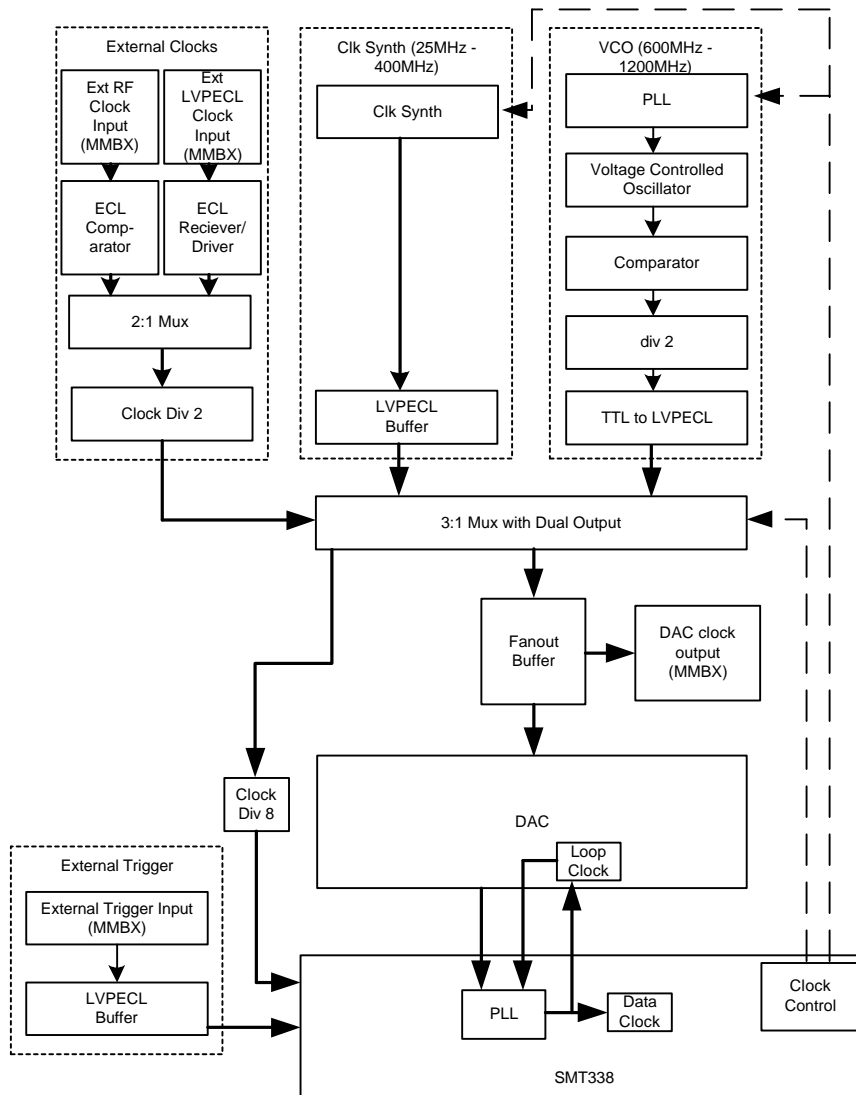

Figure 3. Clock tree of the SMT381.

The main clock tree of the SMT381 consists of two clock sources to achieve the DAC's full range of input frequencies (DC – 500MHz). The first clock source is a MICREL clock synthesizer which has a range from 50MHz to 950MHz. This source's disadvantage however is that it has a jittery output and thus the clock is not that stable. Its advantage however is that it can attain a wide range of frequencies, especially the lower frequencies. The output clock is LVPECL.

The second clock source is a voltage controlled oscillator with a phase lock loop. This combination has a very stable output. However a limited frequency range can be attained by this combination (300MHz – 600MHz). This is achieved by taking a 600MHz -1200MHz VCO and dividing the output by 2. The output clock must also be scaled to LVPECL.

Alternatively the user can provide the module with an external LVPECL clock or an external RF clock. The user can select between any of these input clocks.

The selected clock then drives the DAC and is also distributed to the main module (*SMT338-VP*) for data synchronization purposes. On the FPGA of the *SMT338-VP* a PLL synchronizes the clock with the data being sent by using the supplied clock and looping that same clock to the DAC and back. This technique synchronizes the clock to the data is being sent out on (*SMT338-VP* side) even further with the clock used in the DAC. Synchronization issues become a bigger factor as the clock frequencies get bigger.

All the clock control is done on the *SMT338-VP* side in firmware on the FPGA. The multiplexer selects the clock and this clock is then used inside the DAC and *SMT338-VP* for data transmitting purposes. The set up of the clock packages is also done in firmware.

Finally an external trigger is supplied to the *SMT338-VP* and the multiplexed clock divided by 8. The trigger can be used for memory storing and retrieving functions etc. while the clock divided by 8 is mainly for debugging purposes.

2.7 Trigger Structure

There are two main data-paths (per channel) for data received either from RSL interface (not yet implemented) or SHB/memory interface. The first data path is directly connected to the DAC interface and sends the data as is. The second data path is either a direct link to the DAC interface or to memory. The trigger settings differ depending on the path used.

There are two main sources for the trigger. The first is an LVPECL trigger received over the MMBX connector (triggered on rising edge). The second is a trigger command. The trigger command can be received either over the RSL interface or via the ComPorts.

The following trigger settings are possible for the RSL interface (RSL not yet implemented):

- Start transmitting data when a trigger is received. Stop transmitting when the next trigger is received.
- Transmit a pre-determined amount of samples when a trigger is received.
- Ignore all triggers and transmit data continuously (cycle through memory).

The following trigger settings are possible for the DDR SDRAM data-path:

- Transmit a pre-determined amount of samples when a trigger is received, and carry on cycling through them.

The following diagram is a graphical representation of the trigger structure and sources on the *SMT381* and *SMT338-VP*:

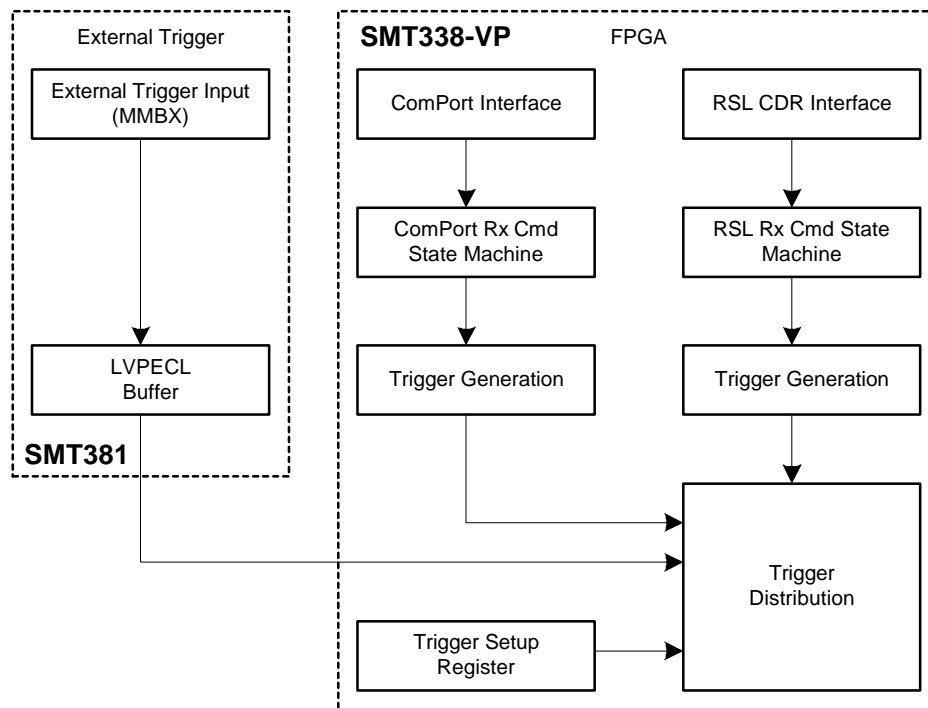

Figure 4. Trigger structure of the *SMT381* and *SMT338-VP*.

2.8 Power Supply and Reset Structure

The *SMT381* uses the following voltages: 12V, -12V, 5V, -5.2V, 3.3V and 1.8V. Only two voltages must be generated on the *SMT381* as the rest are supplied by the carrier. The voltages that must be generated are -5.2V and 1.8V. -5.2V is used for the comparator and op amp in the clock circuitry while 1.8V is used for the serial control interface on the DAC.

All the other voltages are supplied by the carrier and thus present on the *SMT338-VP*. The required voltages are then supplied to the *SMT381* by a daughter card power connector present on the *SMT338-VP* and *SMT381*. The *SMT381* plugs into this power connector and thus has power for all its modules.

Pin X_RESET is the only reset option on the *SMT381*. This pin resides on the DAC. On the falling edge of X_RESET the DAC is reset and all registers are set to their default values. After a reset most parts of the device are powered down.

The following figure shows the power structure of the *SMT338-VP* and *SMT381*:

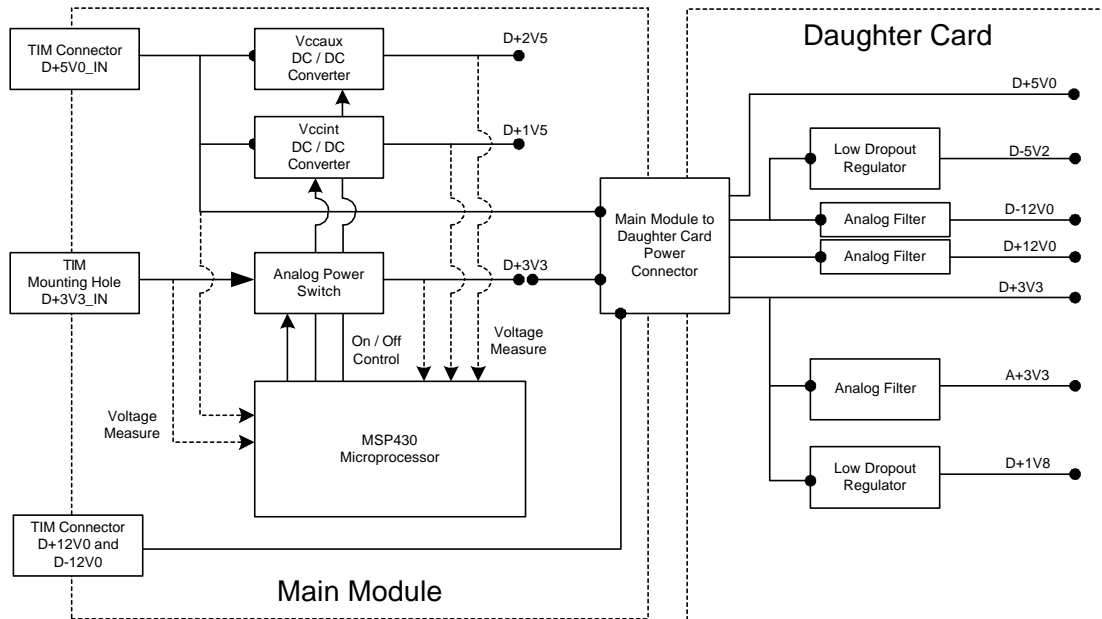

Figure 5. Power Generation and distribution.

2.9 MSP430 Functionality

The MSP430 implements analog control functionality that is difficult to implement in the FPGA. The microprocessor

- Controls the power start-up sequence
- Controls the reset structure on the module

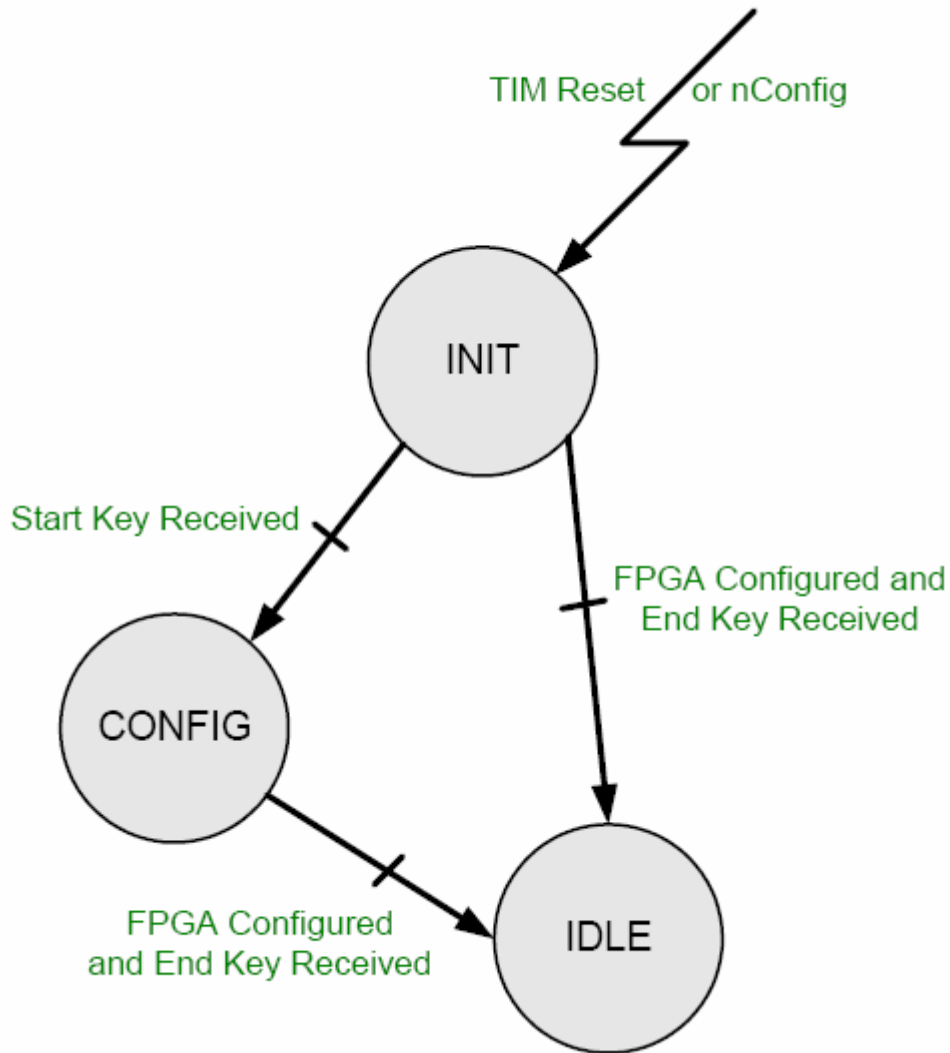

Figure 6. Microcontroller State Machine.

At power-up or on a TIM Reset or on a nConfig line going low, the state machine goes into an *INIT State*. TIM Reset and nConfig lines are available on the carrier module – see TIM Specifications for location on TIM connectors).

From there, it has two choices depending on the state of the FPGA (configured i.e. DONE pin high or un-programmed i.e. DONE Pin Low). To configure the FPGA, simply send a Start Key followed by the bitstream and then an End Key. To re-start the FPGA with the current bitstream loaded, simply send an End Key.

Start Key = 0xBCBCBCBC and End Key = 0xBCBCBC00.

A TIM Reset can be issued to reconfigure the FPGA at anytime, but may reset other modules as well. In the case of reconfiguring a particular module, the nConfig line is used.

MSP430 is connected to ComPort 3 of the TIM. With the standard firmware implementation ComPort 3 is used to communicate with the FPGA. ComPort 0 is open for custom applications as it is not used by the SMT381-VP.

2.10 FPGA Configuration

In a typical Sundance system a carrier and host module (most likely a DSP module) is needed to configure the SMT381-VP.

After a hardware reset the FPGA of the SMT381-VP is un-configured and the microprocessor (MSP430) waits for a data stream. At this point the microprocessor is in control of ComPort 3. The host can then send a data stream over ComPort 3 starting with a STARTKEY, then the data, and ending with an ENDKEY. This will configure the FPGA via the microprocessor, and after configuration the microprocessor will release ComPort3 so that the host can talk straight to the FPGA.

If at any time the host want to reset the FPGA the host must send a reset command to it the SMT381-VP over the ComPort – Any hardware resets coming over the TIM site will be caught by the microprocessor but will not be passed on to the FPGA.

If the FPGA is configured, but the host restarts its application, it must send an ENDKEY only. This will 'wake up' the FPGA and the uP will release ComPort 3 so that the host can use it for FPGA communication.

If the host want to reconfigure the FPGA it must toggle the nConfig line on the TIM site. This will give control of the ComPort back to the microprocessor, but it will not un-configure the FPGA. If the host then start sending a new bit-stream starting with a STARTKEY, the FPGA will be un-configured and the new bit-stream will load. If after toggling the nConfig line, if the host does not want to re-configure the FPGA, it must send an ENDKEY like described above.

The above structure makes it possible to:

- Reset only the FPGA in the system and
- Make sure that the FPGA is not un-configured every time the host application is re-run as it takes time for the FPGA to re-configure (approximately 35 seconds).

2.11 Analogue output section

Two options are hardwired into the design. The options are shown below with a figure of each.

Option 1

Single ended AC coupled output with Macom TP-101 transformer.

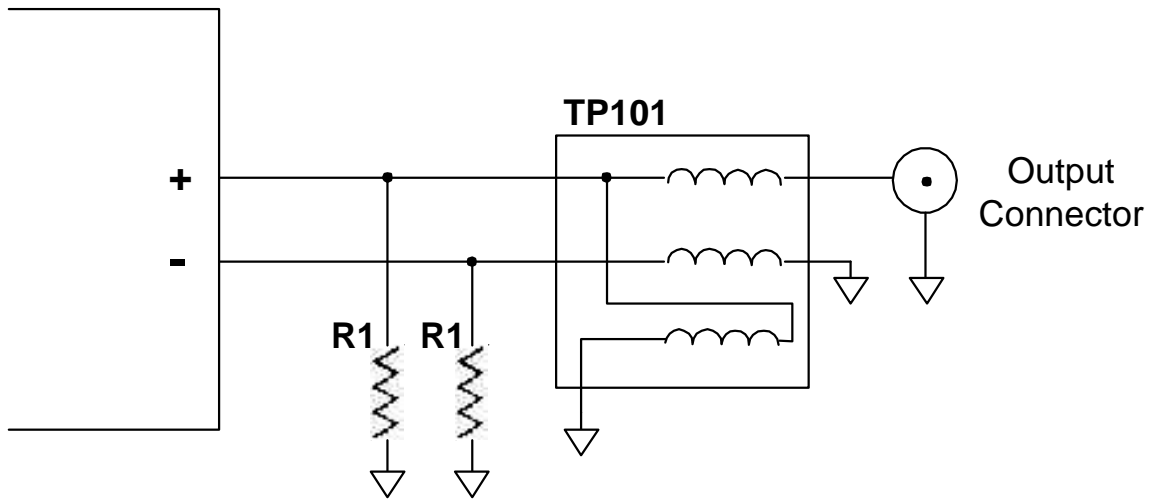

Figure 7. Option 1 for the SMT381 analog output stage.

Option 2

Differential DC coupled output with + and - channels going to separate connectors

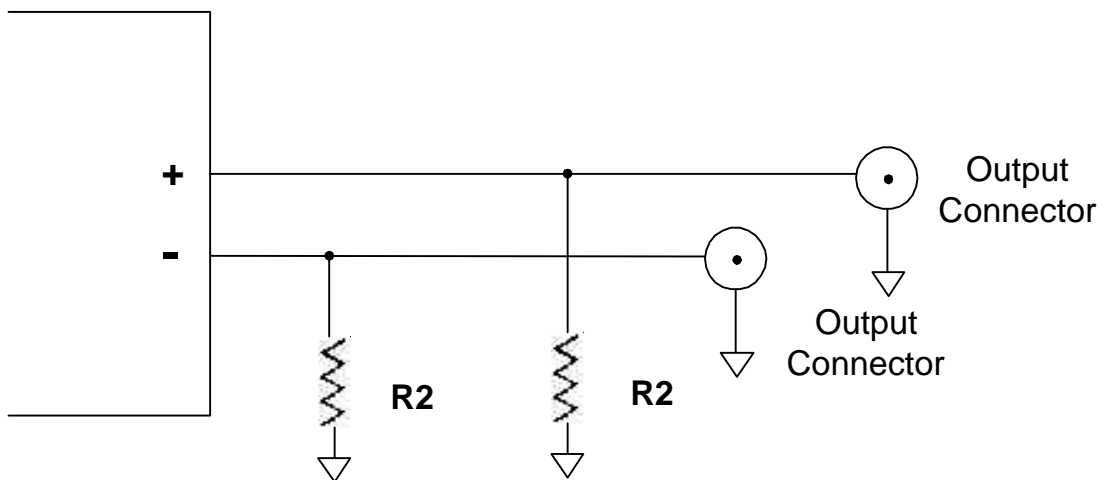

Figure 8. Option 2 for the SMT381 analog output stage.

Combined circuit

The two combined:

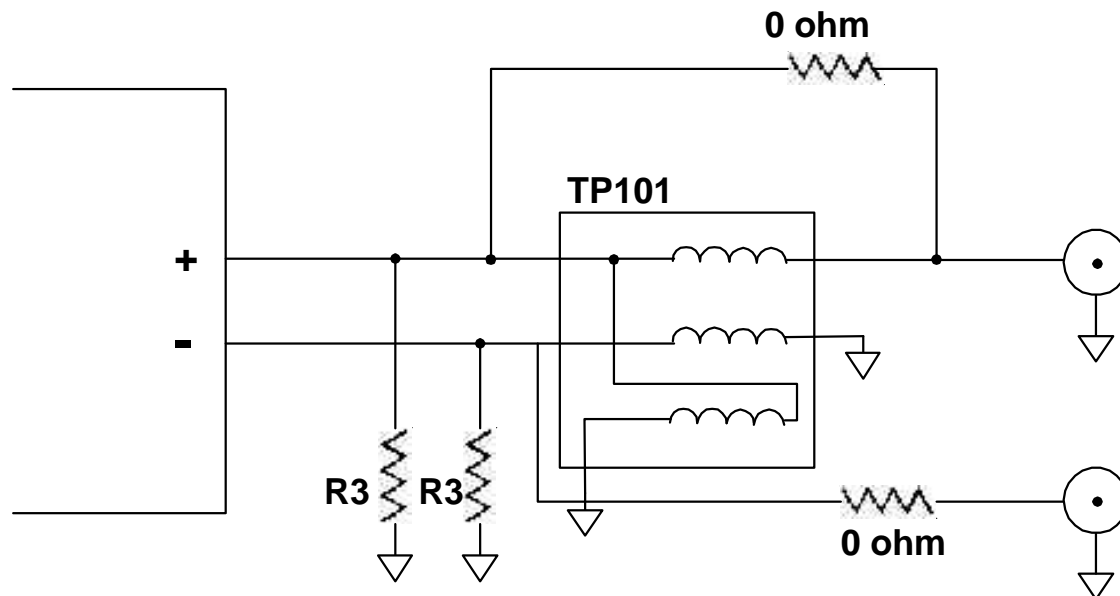

Figure 9. Combined analog output circuit.

Depending on whether an AC or DC coupled version is ordered the board will be assembled accordingly to either give the AC or DC coupled circuit shown above.

For more information consult the Fujitsu (MB86064) DAC datasheet [6].

2.12 DAC Settings

All DAC settings are controlled and implemented by the 4 wire serial control interface. The serial interface uses pins SERIAL_IN, SERIAL_OUT, SERIAL_CLK and SERIAL_EN. Programmed settings are stored in a number of registers which are individually accessible using either a 7-bit (WMM Registers) or 10-bit (DAC Core Registers) address/control word. Data may be written to or read from each of these registers.

For more information consult the Fujitsu (MB86064) DAC datasheet [6].

3 Description of interfaces

3.1 DAC Control Interface

A four wire uni-directional control interface is implemented between the FPGA and the DAC. This interface is used for clocking configuration information into the DAC.

Note 1: The serial interface on the DAC side uses 1.8V signalling levels. These control lines are however connected onto a 3.3V bank on the FPGA with additional pull-up resistors on the SMT381 to 1.8V. For this reason the FPGA firmware may never drive '1' out on these pins as it will drive the DAC at 3.3V and thus damage it. The firmware may only drive '0' for '0' and 'Z' for '1'. Because of the pull-up resistor the 'Z' will be pulled up to 1.8V. This approach works well and any used wishing to develop his own firmware is advised to take a look at the SMT381 example firmware before developing his own.

3.2 DAC Data Interface

The output of each channel from the SMT338-VP to the DAC is a 14 bit LVDS data bus clocked on the synchronized DAC clock.

Note 1: The data bus between the FPGA and the DAC is wired in a strange way to assist routing. If a user wants to develop his own VHDL design and not use the example design he is advised to take a look at the wiring of the example design to assist him with his own design.

Note 2: On Rev 01 of the SMT381 the positive and negative data pairs of the LVDS bus between the FPGA and the DAC is swapped for one of the two channels. This results in a data flip. This issue is corrected in firmware by inverting the data before writing it out over the interface. Once again any user wanting to do his own design is advised to take a look at the example firmware design.

3.3 Memory Interface

Two groups of two 16 bit Micron DDR SDRAMs form the volatile sample storage space of the module. Each DDR SDRAM is 256 Mbits in size. This provides the module with a total of 64Mbytes (or 32 Mega samples) of storage space per channel. Each channel contains a 32 bit DDR SDRAM controller. This interface is capable of data transfer at 1 GBytes / s. It is thus fast enough to write the outgoing DAC data stream.

3.4 MSP430 Interface

After configuration the microprocessor communicates with the FPGA using the IO pins of the FPGA Slave Select Configuration interface. The MSP is the master of the interface and will continually write the serial number and the measured on-board voltages to the FPGA. A system host can then read this data from the FPGA over the ComPort interface.

3.5 Serial Number

A Maxim 1-Wire silicon serial number device is located on the SMT381 and the SMT338-VP. This is used to assign a unique serial number to each module.

3.6 PLL Interface

A three wire uni-directional control interface is implemented between the FPGA and the PLL on the daughter card. This PLL sets and controls the voltage for the VCO that generates the main clock.

3.7 Clock Synthesizer Interface

A three wire uni-directional control interface is implemented between the FPGA and the Micrel clock synthesizer on the daughter card. The clock synthesizer can generate a variable 50 – 950 MHz clock. The jitter on this clock is higher than on the main PLL+VCO clock, but it is convenient for testing.

3.8 TIM Interface

The SMT381-VP implements ComPorts 0 and 3. There are no DIP switches on the module and all configuration data is received and transmitted over these two ports. The ComPorts are not used for DAC data transfer. ComPort 3 is implemented as a bi-directional transceiver interface for FPGA configuration and control operations. ComPort 0 is available but not used in the default firmware provided with the board.

The Global Bus Interface is not implemented on the SMT381. Refer to [3] for a more detailed description of the TIM interface.

3.9 External Trigger

The external trigger input is received by a LVPECL input buffer on the SMT381. The buffered signal is passed down as a differential LVPECL signal to the FPGA on the SMT338-VP. For compatibility reasons with other daughter card modules there are no ECL termination resistors mounted on the SMT338-VP. For this reason the pulse width of the input trigger must be at least 1uS before the FPGA will register it.

As this might be a problem for some applications this issue has been resolved on the newer SMT338-VP modules and appropriate termination resistors are provided to improve the response time of the FPGA to an external trigger.

For most systems it is likely that there will be a system host (DSP Module). For this reason it is also possible to send a software trigger to the SMT381-VP over ComPort 3. There will however be a latency from the time that the command is sent to the time that data is read from the memory.

3.10 Daughter card Interface

The daughter-card interface is made up of two connectors. The one is a 0.5mm pitch differential Samtec connector. This connector is for transferring digital LVDS data to the DAC from the main module. The second one is a 1mm pitch Samtec header type connector. This connector is for providing power to the daughter-card.

The figure underneath illustrates this configuration. The bottom view of the daughter card is shown on the right. This view must be mirrored to understand how it connects to the main module.

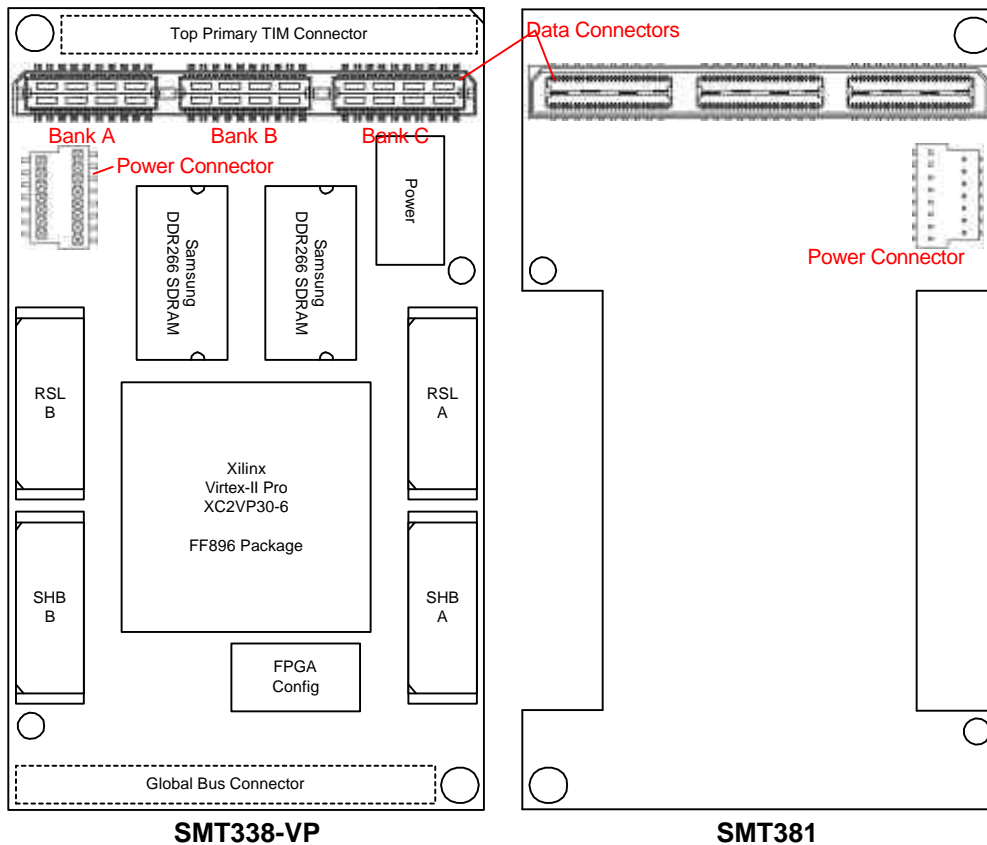

Figure 10. Daughter card connector interface

The female differential connector is located on the main module. The Samtec Part Number for this connector is QTH-060-01-F-D-DP-A.

The female power connector is located on the main module. The Samtec Part Number for this connector is BKS-107-01-F-V-A

The male differential connector is located on the daughter card. The Samtec Part Number for this connector is QSH-060-01-F-D-DP-A

The male power connector is located on the daughter card. The Samtec Part Number for this connector is BKT-107-03-F-V-A

The mated height between the main module and the daughter card is 5 mm.

Each pin on the power connector can carry 1.5 A. Digital 5V (D+5V0), digital 3V3 (D+3V3), digital 12V0 (D+12V0), digital -12V0 (D-12V0) and digital ground (DGND) is provided over this connector. D+3V3 and D+5V0 are assigned four pins each while D+12V0 and D-12V0 are assigned two each. The daughter card can thus draw a total of 6A for the D+3V3 and D+5V0 supplies while D+12V0 and D-12V0 can only supply 3A. The integral ground plane on the differential connector provides additional grounding. The following table shows the pin assignment on the power connector:

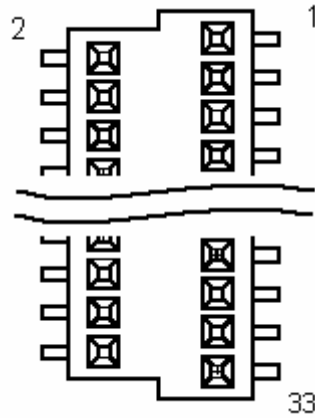

Pin Number	Pin Name	Description of Signal
1	D+3V3	Digital 3.3 Volts
2	DGND	Digital Ground
3	D+3V3	Digital 3.3 Volts
4	DGND	Digital Ground
5	D+3V3	Digital 3.3 Volts
6	DGND	Digital Ground
7	D+3V3	Digital 3.3 Volts
8	DGND	Digital Ground
9	D+5V0	Digital 5.0 Volts
10	DGND	Digital Ground
11	D+5V0	Digital 5.0 Volts
12	DGND	Digital Ground
13	D+5V0	Digital 5.0 Volts
14	DGND	Digital Ground
15	D+5V0	Digital 5.0 Volts
16	DGND	Digital Ground
17	D+12V0	Digital 12.0 Volts
18	DGND	Digital Ground
19	D+12V0	Digital 12.0 Volts
20	DGND	Digital Ground
21	D-12V0	Digital -12.0 Volts
22	DGND	Digital Ground
23	D-12V0	Digital -12.0 Volts
24	DGND	Digital Ground
25	DGND	Digital Ground
26	NC	
27	NC	
28	NC	
29	NC	
30	NC	

31	TDI	Loop with TDO
32	TDO	Loop with TDI
33	DGND	Digital Ground

Table 2. Daughter Card Interface Power Connector and Pinout.

The following few pages describes the signals on the data connector between the main module and the daughter card. Bank A on the connector is used for the DAC Channel A data bus. Bank C is used for the DAC channel B data bus. Bank B is used for system clock and trigger signals, DAC control signals and general system control signals. The general system control signals include: clock control interface (for the clock modules present on the *SMT381*), daughter card sense signal, daughter card ID signals, low drop out regulator control signals and daughter card DAC reset signal. All reserved signals are connected to the FPGA on the main module for future expansion.

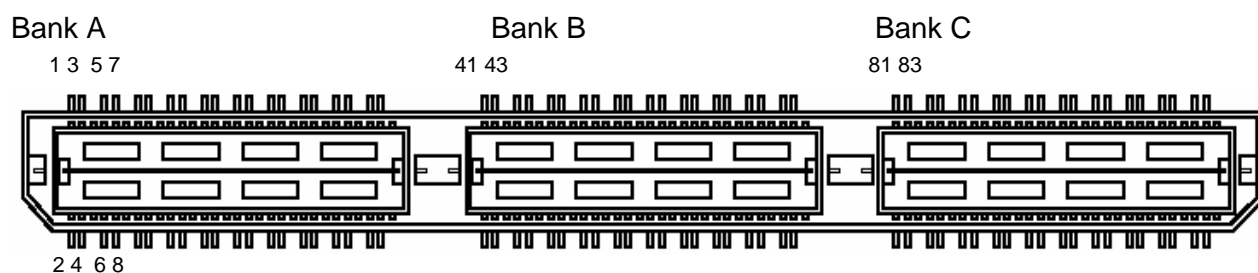

Bank A

Pin No	Pin Name	Signal Description	Pin No	Pin Name	Signal Description
Dir	Main Module to Daughter Card		Dir	Main Module to Daughter Card	
1	DOAI0p	Data In 0 Channel A, pos.	2	DOBI0p	Data In 1 Channel A, pos.
3	DOAI0n	Data In 0 Channel A, neg.	4	DOBI0n	Data In 1 Channel A, neg.
Dir	Main Module to Daughter Card		Dir	Main Module to Daughter Card	
5	DOAI1p	Data In 2 Channel A, pos.	6	DOBI1p	Data In 3 Channel A, pos.
7	DOAI1n	Data In 2 Channel A, neg.	8	DOBI1n	Data In 3 Channel A, neg.
Dir	Main Module to Daughter Card		Dir	Main Module to Daughter Card	
9	DOAI2p	Data In 4 Channel A, pos.	10	DOBI2p	Data In 5 Channel A, pos.
11	DOAI2n	Data In 4 Channel A, neg.	12	DOBI2n	Data In 5 Channel A, neg.
Dir	Main Module to Daughter Card		Dir	Main Module to Daughter Card	
13	DOAI3p	Data In 6 Channel A, pos.	14	DOBI3p	Data In 7 Channel A, pos.
15	DOAI3n	Data In 6 Channel A, neg.	16	DOBI3n	Data In 7 Channel A, neg.
Dir	Main Module to Daughter Card		Dir	Main Module to Daughter Card	
17	DOAI4p	Data In 8 Channel A, pos.	18	DOBI4p	Data In 9 Channel A, pos.
19	DOAI4n	Data In 8 Channel A, neg.	20	DOBI4n	Data In 9 Channel A, neg.
Dir	Main Module to Daughter Card		Dir	Main Module to Daughter Card	
21	DOAI5p	Data In 10 Channel A, pos.	22	DOBI5p	Data In 11 Channel A, pos.
23	DOAI5n	Data In 10 Channel A, neg.	24	DOBI5n	Data In 11 Channel A, neg.
Dir	Main Module to Daughter Card		Dir	Main Module to Daughter Card	
25	DOAI6p	Data In 12 Channel A, pos.	26	DOBI6p	Data In 13 Channel A, pos.
27	DOAI6n	Data In 12 Channel A, neg.	28	DOBI6n	Data In 13 Channel A, neg.
Dir	Reserved		Dir	Reserved	
29	Reserved	Reserved	30	Reserved	Reserved
31	Reserved	Reserved	32	Reserved	Reserved
Dir	Daughter Card to Main Module		Dir	Main Module to Daughter Card	
33	ClkOlp	Output Ready, I channel, pos	34	DOIRlp	Loop back clock to DAC, pos.
35	ClkOln	Output Ready, I channel, neg	36	DOIRln	Loop back clock to DAC, neg.
Dir	Daughter Card to Main Module		Dir	Daughter Card to Main Module	
37	SysClockp	System clock, pos.	38	ExtTriggerlp	External Trigger A, pos.
39	SysClockn	System clock, neg.	40	ExtTriggerln	External Trigger A, neg.

Figure 11. Daughter Card Interface: Data Signals Connector and Pinout (Bank A).

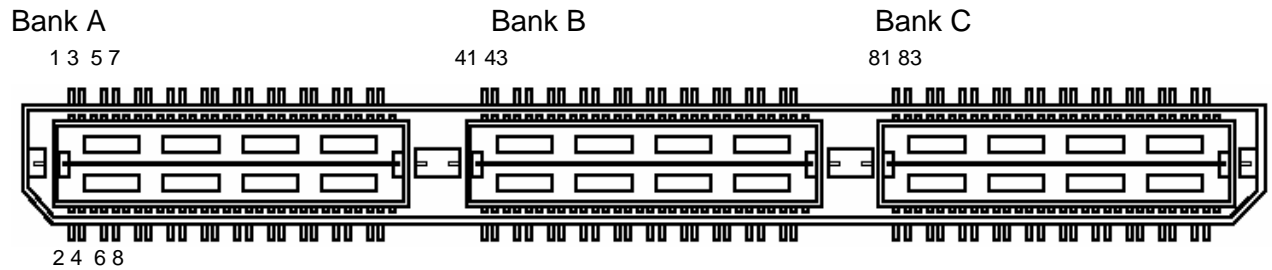

Bank B

Pin No	Pin Name	Signal Description	Pin No	Pin Name	Signal Description
Type			MSP system signals		
Dir			Bi-Directional		
41	SMBClk	TmpCntrl0	42	SMBData	TmpCntrl1
43	SMBnAlert	TmpCntrl2	44	SerialNo	Serial Number
45	Reserved	Reserved	46	Reserved	Reserved
47	Reserved	Reserved	48	Reserved	Reserved
49	D3V3Enable	D3V3Enable	50	D1V8Enable	D1V8Enable
Type			FPGA system signals		
Dir			Bi-Directional		
51	DACCntrl0	DAC Control 0	52	DACCntrl0	DAC Control 1
53	DACCntrl0	DAC Control 2	54	DACCntrl0	DAC Control 3
55	DACCntrl0	DAC Control 4	56	AdjClkSClk	AdjClockCntrl0
57	AdjClkSData	AdjClockCntrl1	58	AdjClkSLoad	AdjClockCntrl2
59	AdjClkTest	AdjClockCntrl3	60	PIIClk	PIICntrl0
61	PIIData	PIICntrl1	62	PIILe	PIICntrl2
63	PIIFoLd	PIICntrl3	64	AdcAClkSel	AdcAClkSel
65	AdcBClkSel	AdcBClkSel	66	IntClkDivEn	IntClkDivEnable
67	IntClkDivnReset	IntClkDivnReset	68	IntExtClkSel	IntExtClkSel
69	IntExtClkSelnReset	IntExtClkSelnReset			
Type			FPGA JTAG		
Dir			Bi-Directional		
			70	FpgaVref	FpgaVref
71	FpgaTck	FpgaTck	72	FpgaTms	FpgaTms
73	FpgaTdi	FpgaTdi	74	FpgaTdo	FpgaTdo
Type			MSP JTAG		
Dir			Bi-Directional		
75	MspVref	MspVref	76	MspTck	MspTck
77	MspTms	MspTms	78	MspTdi	MspTdi
79	MspTdo	MspTdo	80	MspnTrst	MspnTrst

Figure 12. Daughter Card Interface: Data Signals Connector and Pinout (Bank B).

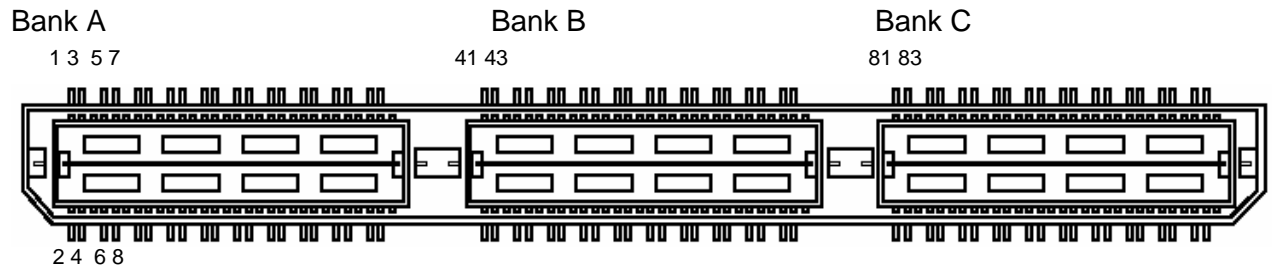

Bank C

Pin No	Pin Name	Signal Description	Pin No	Pin Name	Signal Description
Dir	Daughter Card to Main Module		Dir	Daughter Card to Main Module	
81	DOAQ0p	Data In 0 Channel B, pos.	82	DOBQ0p	Data In 1 Channel B, pos.
83	DOAQ0n	Data In 0 Channel B, neg.	84	DOBQ0n	Data In 1 Channel B, neg.
Dir	Daughter Card to Main Module		Dir	Daughter Card to Main Module	
85	DOAQ1p	Data In 2 Channel B, pos.	86	DOBQ1p	Data In 3 Channel B, pos.
87	DOAQ1n	Data In 2 Channel B, neg.	88	DOBQ1n	Data In 3 Channel B, neg.
Dir	Daughter Card to Main Module		Dir	Daughter Card to Main Module	
89	DOAQ2p	Data In 4 Channel B, pos.	90	DOBQ2p	Data In 5 Channel B, pos.
91	DOAQ2n	Data In 4 Channel B, neg.	92	DOBQ2n	Data In 5 Channel B, neg.
Dir	Daughter Card to Main Module		Dir	Daughter Card to Main Module	
93	DOAQ3p	Data In 6 Channel B, pos.	94	DOBQ3p	Data In 7 Channel B, pos.
95	DOAQ3n	Data In 6 Channel B, neg.	96	DOBQ3n	Data In 7 Channel B, neg.
Dir	Daughter Card to Main Module		Dir	Daughter Card to Main Module	
97	DOAQ4p	Data In 8 Channel B, pos.	98	DOBQ4p	Data In 9 Channel B, pos.
99	DOAQ4n	Data In 8 Channel B, neg.	100	DOBQ4n	Data In 9 Channel B, neg.
Dir	Daughter Card to Main Module		Dir	Daughter Card to Main Module	
101	DOAQ5p	Data In 10 Channel B, pos.	102	DOBQ5p	Data In 11 Channel B, pos.
103	DOAQ5n	Data In 10 Channel B, neg.	104	DOBQ5n	Data In 11 Channel B, neg.
Dir	Daughter Card to Main Module		Dir	Daughter Card to Main Module	
105	DOAQ6p	Data In 12 Channel B, pos.	106	DOBQ6p	Data In 13 Channel B, pos.
107	DOAQ6n	Data In 12 Channel B, neg.	108	DOBQ6n	Data In 13 Channel B, neg.
Dir	Reserved		Dir	Reserved	
109	Reserved	Reserved	110	Reserved	Reserved
111	Reserved	Reserved	112	Reserved	Reserved
Dir	Daughter Card to Main Module		Dir	Daughter Card to Main Module	
113	ClkOQp	Output Ready, Q channel, pos	114	DOIRQp	Loop back clock to FPGA, pos.
115	ClkOQn	Output Ready, Q channel, neg	116	DOIRQn	Loop back clock to FPGA, neg.
Dir	Daughter Card to Main Module		Dir	Daughter Card to Main Module	
117	RslClockp	Rsl Clock, pos.	118	ExtTriggerQp	External Trigger A, pos.
119	RslClockn	Rsl Clock, neg.	120	ExtTriggerQn	External Trigger A, neg.

Figure 13. Daughter Card Interface: Data Signals Connector and Pinout (Bank C).

3.11 RSL Interface (RSL not yet available)

3.11.1 RSL Connector and Pinout Definition

The Rocket Serial Link (RSL) is a serial based communications interconnection standard that is capable of transfer speeds of up to 2.5Gbit/s per link. Up to four links can be combined to form a Rocket Serial Link Communications Channel (RSLCC) that is capable of data transfer up to 10Gbit/s.

Each RSL is made up of a differential Tx and Rx pair. A single RSL can thus transfer data at 2.5Gbit/s in both directions at the same time. Rocket Serial Link interconnections are based on the RocketIO standard used on Xilinx Virtex-II Pro FPGAs. Rocket Serial Links uses Low Voltage Differential Signaling (LVDS).

The SMT381-VP uses a subset of the RSL specification. Four RSLs are combined to form a 10Gbit/s RSLCC. One RSLCC per DAC channel is implemented on the SMT381-VP. The RSLCC is thus capable to transfer a raw data stream to the DAC in real time.

The connector used for the RSL interface is a 0.8mm pitch differential Samtec connector. The part number for this connector is: QSE-014-01-F-D-DP-A. The RSL connector takes the place of the optional 3rd and 4th SHB connector on a TIM module. The following diagram shows the position of the RSL connectors on the SMT381-VP:

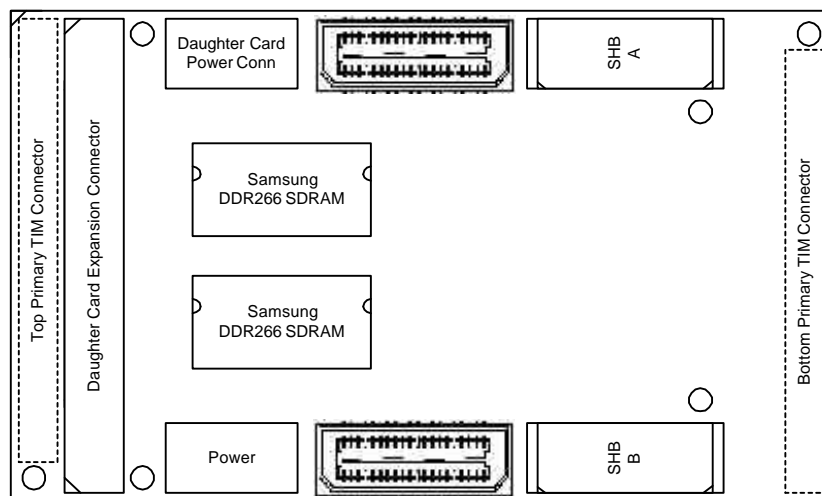
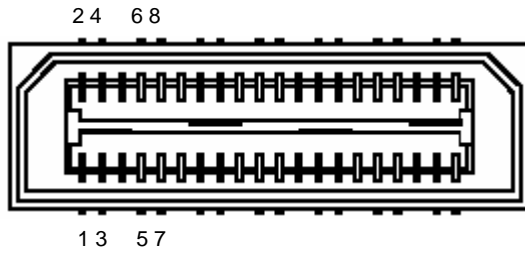

Figure 14. Rocket Serial Link Interface.

There are two additional RSL footprints underneath the module (by default not mounted) in the same place as top RSL connectors. By mounting these two connectors and not the top two it is possible to plug the SMT381-VP straight onto an RSL enabled carrier without having to interconnect the links with cables.



RSL A

Pin No	Pin Name	Signal Description	Pin No	Pin Name	Signal Description
Dir	Carrier / Other Module to SMT381-VP		Dir	SMT381-VP to Carrier / Other Module	
1	RxLink0p	Receive Link 0, positive	2	TxLink0p	Transmit Link 0, positive
3	RxLink0n	Receive Link 0, negative	4	TxLink0n	Transmit Link 0, negative
Dir	Carrier / Other Module to SMT381-VP		Dir	SMT381-VP to Carrier / Other Module	
5	RxLink1p	Receive Link 1, positive	6	TxLink1p	Transmit Link 1, positive
7	RxLink1n	Receive Link 1, negative	8	TxLink1n	Transmit Link 1, negative
Dir	Carrier / Other Module to SMT381-VP		Dir	SMT381-VP to Carrier / Other Module	
9	RxLink2p	Receive Link 2, positive	10	TxLink2p	Transmit Link 2, positive
11	RxLink2n	Receive Link 2, negative	12	TxLink2n	Transmit Link 2, negative
Dir	Carrier / Other Module to SMT381-VP		Dir	SMT381-VP to Carrier / Other Module	
13	RxLink3p	Receive Link 3, positive	14	TxLink3p	Transmit Link 3, positive
15	RxLink3n	Receive Link 3, negative	16	TxLink3n	Transmit Link 3, negative
Dir	Reserved		Dir	Reserved	
17	Reserved	Reserved	18	Reserved	Reserved
19	Reserved	Reserved	20	Reserved	Reserved
Dir	Reserved		Dir	Reserved	
21	Reserved	Reserved	22	Reserved	Reserved
23	Reserved	Reserved	24	Reserved	Reserved
Dir	Reserved		Dir	Reserved	
25	Reserved	Reserved	26	Reserved	Reserved
27	Reserved	Reserved	28	Reserved	Reserved

Figure 15. Rocket Serial Link Interface Connector and Pinout (RSL A).

RSL B

Pin No	Pin Name	Signal Description	Pin No	Pin Name	Signal Description
Dir	Carrier / Other Module to SMT381-VP		Dir	SMT381-VP to Carrier / Other Module	
1	RxLink0p	Receive Link 0, positive	2	TxLink0p	Transmit Link 0, positive
3	RxLink0n	Receive Link 0, negative	4	TxLink0n	Transmit Link 0, negative
Dir	Carrier / Other Module to SMT381-VP		Dir	SMT381-VP to Carrier / Other Module	
5	RxLink1p	Receive Link 1, positive	6	TxLink1p	Transmit Link 1, positive
7	RxLink1n	Receive Link 1, negative	8	TxLink1n	Transmit Link 1, negative
Dir	Carrier / Other Module to SMT381-VP		Dir	SMT381-VP to Carrier / Other Module	
9	RxLink2p	Receive Link 2, positive	10	TxLink2p	Transmit Link 2, positive
11	RxLink2n	Receive Link 2, negative	12	TxLink2n	Transmit Link 2, negative

Dir	Carrier / Other Module to SMT381-VP		Dir	SMT381-VP to Carrier / Other Module	
13	RxLink3p	Receive Link 3, positive	14	TxLink3p	Transmit Link 3, positive
15	RxLink3n	Receive Link 3, negative	16	TxLink3n	Transmit Link 3, negative
Dir	Reserved		Dir	Reserved	
17	Reserved	Reserved	18	Reserved	Reserved
19	Reserved	Reserved	20	Reserved	Reserved
Dir	Reserved		Dir	Reserved	
21	Reserved	Reserved	22	Reserved	Reserved
23	Reserved	Reserved	24	Reserved	Reserved
Dir	Reserved		Dir	Reserved	
25	Reserved	Reserved	26	Reserved	Reserved
27	Reserved	Reserved	28	Reserved	Reserved

Figure 16. Rocket Serial Link Interface Connector and Pinout (RSL B).

3.11.2 RSL Cable Definition

The matching cable for the RSL connector is a Samtec High Speed Data Link Cable (Samtec HFEM Series). The cable may be ordered with different length and mating connector options. The following diagram shows such a typical cable:

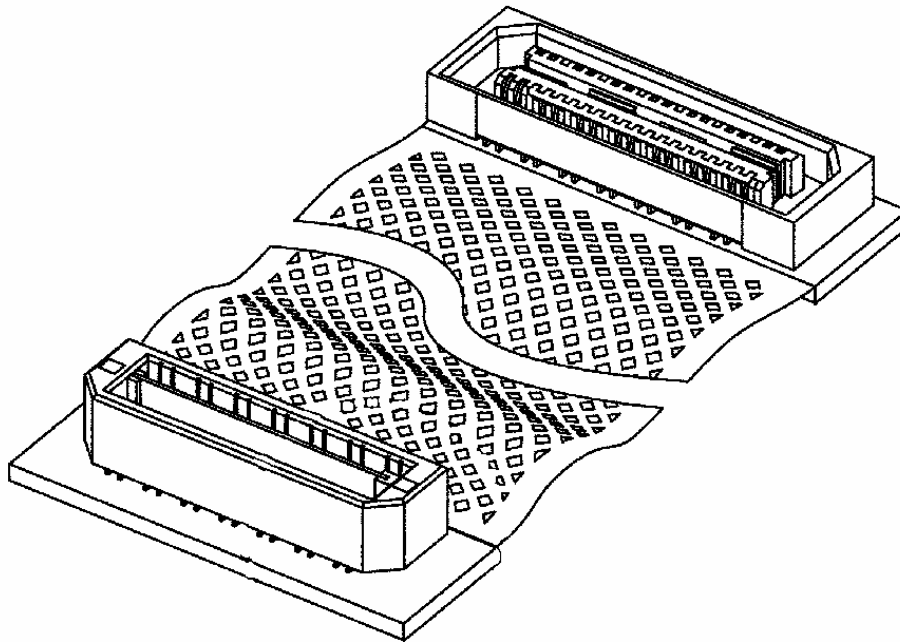

Figure 17. Samtec HFEM Series Data Cable.

3.12 SHB Interface

The SMT381-VP implements a subset of the full SHB implementation. Two configurations are possible

Configuration 1: SHB A is configured to receive 32-bit data words for channel A and SHB B is configured to receive 32-bit data words for channel B. Both SHB interfaces

are configured as inputs only. Control and configuration data is received over ComPort 3. The SHB interface is clocked by the SMT338-VP system clock of 53MHz. Configuration 2: Either SHB A or SHB B is configured to receive two 16-bit half-words. The first 16-bits is used for data for channel A and the second 16-bits is used for data for channel B. (This option is not implemented in firmware.)

The first configuration is ideal for higher speed data transfer. The second configuration can be used if just one SHB is available on a module that the SMT381-VP interfaces to. The two possible configurations are illustrated in the following figure:

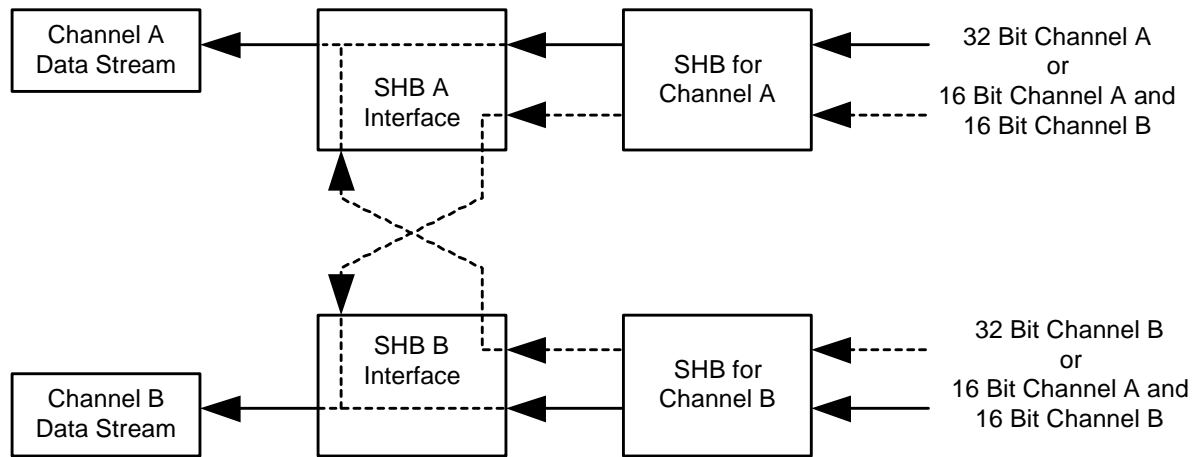
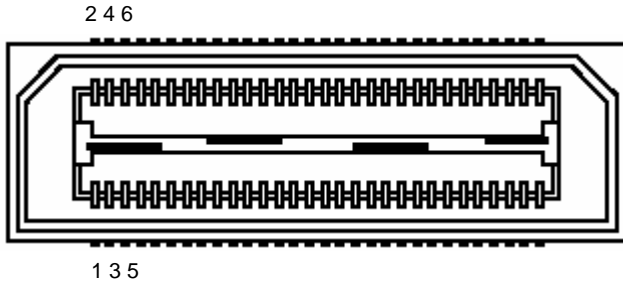

Figure 18. Possible SHB Configurations.

The connector used for the SHB interface is a 0.5mm Samtec QSH Type connector. The full part number for this connector is: QSH-030-01-L-D-A-K

The pinout information for the two possible configurations for both SHB connectors is given in the following table:



SHB A and SHB B, Configuration 1 (X = A for SHB A, X = B for SHB B)

Pin No	Pin Name	Direction	Signal Description	Pin No	Pin Name	Direction	Signal Description
1	ChXClk	To 381	Ch X, Word Clock	31	ChXD29	To 381	Ch X, Word Data 29
2	ChXD0	To 381	Ch X, Word Data 0	32	ChXD30	To 381	Ch X, Word Data 30
3	ChXD1	To 381	Ch X, Word Data 1	33	ChXD31	To 381	Ch X, Word Data 31
4	ChXD2	To 381	Ch X, Word Data 2	34	ChXWen	To 381	Ch X, Write Enable
5	ChXD3	To 381	Ch X, Word Data 3	35	ChXReq	Reserved	Not Implemented
6	ChXD4	To 381	Ch X, Word Data 4	36	ChXAck	Reserved	Not Implemented
7	ChXD5	To 381	Ch X, Word Data 5	37	Reserved	Reserved	Reserved
8	ChXD6	To 381	Ch X, Word Data 6	38	Reserved	Reserved	Reserved
9	ChXD7	To 381	Ch X, Word Data 7	39	Reserved	Reserved	Reserved
10	ChXD8	To 381	Ch X, Word Data 8	40	Reserved	Reserved	Reserved
11	ChXD9	To 381	Ch X, Word Data 9	41	Reserved	Reserved	Reserved
12	ChXD10	To 381	Ch X, Word Data 10	42	Reserved	Reserved	Reserved
13	ChXD11	To 381	Ch X, Word Data 11	43	Reserved	Reserved	Reserved
14	ChXD12	To 381	Ch X, Word Data 12	44	Reserved	Reserved	Reserved
15	ChXD13	To 381	Ch X, Word Data 13	45	Reserved	Reserved	Reserved
16	ChXD14	To 381	Ch X, Word Data 14	46	Reserved	Reserved	Reserved
17	ChXD15	To 381	Ch X, Word Data 15	47	Reserved	Reserved	Reserved
18	ChXD16	To 381	Ch X, Word Data 16	48	Reserved	Reserved	Reserved
19	ChXD17	To 381	Ch X, Word Data 17	49	Reserved	Reserved	Reserved
20	ChXD18	To 381	Ch X, Word Data 18	50	Reserved	Reserved	Reserved
21	ChXD19	To 381	Ch X, Word Data 19	51	Reserved	Reserved	Reserved
22	ChXD20	To 381	Ch X, Word Data 20	52	Reserved	Reserved	Reserved
23	ChXD21	To 381	Ch X, Word Data 21	53	Reserved	Reserved	Reserved
24	ChXD22	To 381	Ch X, Word Data 22	54	Reserved	Reserved	Reserved
25	ChXD23	To 381	Ch X, Word Data 23	55	Reserved	Reserved	Reserved
26	ChXD24	To 381	Ch X, Word Data 24	56	Reserved	Reserved	Reserved
27	ChXD25	To 381	Ch X, Word Data 25	57	Reserved	Reserved	Reserved
28	ChXD26	To 381	Ch X, Word Data 26	58	Reserved	Reserved	Reserved
29	ChXD27	To 381	Ch X, Word Data 27	59	Reserved	Reserved	Reserved
30	ChXD28	To 381	Ch X, Word Data 28	60	Reserved	Reserved	Reserved

Figure 19. SHB Connector Configuration 1 Pinout.

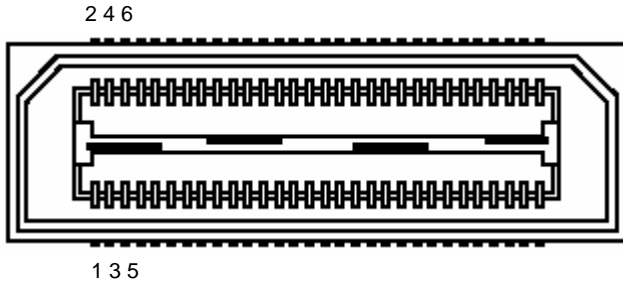

SHB A and SHB B, Configuration 2

Pin No	Pin Name	Direction	Signal Description	Pin No	Pin Name	Direction	Signal Description
1	ChAClk	To 381	Ch A, ½Word Clock	31	Reserved	Reserved	Reserved
2	ChAD0	To 381	Ch A, ½Word Data 0	32	Reserved	Reserved	Reserved
3	ChAD1	To 381	Ch A, ½Word Data 1	33	Reserved	Reserved	Reserved
4	ChAD2	To 381	Ch A, ½Word Data 2	34	Reserved	Reserved	Reserved
5	ChAD3	To 381	Ch A, ½Word Data 3	35	Reserved	Reserved	Reserved
6	ChAD4	To 381	Ch A, ½Word Data 4	36	Reserved	Reserved	Reserved
7	ChAD5	To 381	Ch A, ½Word Data 5	37	ChBClk	To 381	Ch B, ½Word Clock
8	ChAD6	To 381	Ch A, ½Word Data 6	38	ChBD0	To 381	Ch B, ½Word Data 0
9	ChAD7	To 381	Ch A, ½Word Data 7	39	ChBD1	To 381	Ch B, ½Word Data 1
10	ChAD8	To 381	Ch A, ½Word Data 8	40	ChBD2	To 381	Ch B, ½Word Data 2
11	ChAD9	To 381	Ch A, ½Word Data 9	41	ChBD3	To 381	Ch B, ½Word Data 3
12	ChAD10	To 381	Ch A, ½Word Data 10	42	ChBD4	To 381	Ch B, ½Word Data 4
13	ChAD11	To 381	Ch A, ½Word Data 11	43	ChBD5	To 381	Ch B, ½Word Data 5
14	ChAD12	To 381	Ch A, ½Word Data 12	44	ChBD6	To 381	Ch B, ½Word Data 6
15	ChAD13	To 381	Ch A, ½Word Data 13	45	ChBD7	To 381	Ch B, ½Word Data 7
16	ChAD14	To 381	Ch A, ½Word Data 14	46	ChBD8	To 381	Ch B, ½Word Data 8
17	ChAD15	To 381	Ch A, ½Word Data 15	47	ChBD9	To 381	Ch B, ½Word Data 9
18	ChAUser0	Reserved	Not Implemented	48	ChBD10	To 381	Ch B, ½Word Data 10
19	ChAUser1	Reserved	Not Implemented	49	ChBD11	To 381	Ch B, ½Word Data 11
20	ChAUser2	Reserved	Not Implemented	50	ChBD12	To 381	Ch B, ½Word Data 12
21	ChAUser3	Reserved	Not Implemented	51	ChBD13	To 381	Ch B, ½Word Data 13
22	ChAWen	To 381	Ch A, Write Enable	52	ChBD14	To 381	Ch B, ½Word Data 14
23	ChAReq	Reserved	Not Implemented	53	ChBD15	To 381	Ch B, ½Word Data 15
24	ChAAck	Reserved	Not Implemented	54	ChBUser0	Reserved	Not Implemented
25	Reserved	Reserved	Reserved	55	ChBUser1	Reserved	Not Implemented
26	Reserved	Reserved	Reserved	56	ChBUser2	Reserved	Not Implemented
27	Reserved	Reserved	Reserved	57	ChBUser3	Reserved	Not Implemented
28	Reserved	Reserved	Reserved	58	ChBWen	To 381	Ch B, Write Enable
29	Reserved	Reserved	Reserved	59	ChBReq	Reserved	Not Implemented
30	Reserved	Reserved	Reserved	60	ChBAck	Reserved	Not Implemented

Figure 20. SHB Connector Configuration 2 Pinout.

4 Firmware Description

4.1 Main States

At reset, the FPGA is in the INIT state where internal memory and registers are reset. It then waits for data from the SHB interface to write to the DDR memory (state "STORE"). Once the memory is full, upon a trigger, data is read back and written to the DAC (state "READ BACK"). When the whole memory has been read back the FPGA can carry on cycling through the memory, or go back into the "WAIT START CMD" state and wait for a new data from the SHB interface. The following diagram describes the sequence of events during an acquisition:

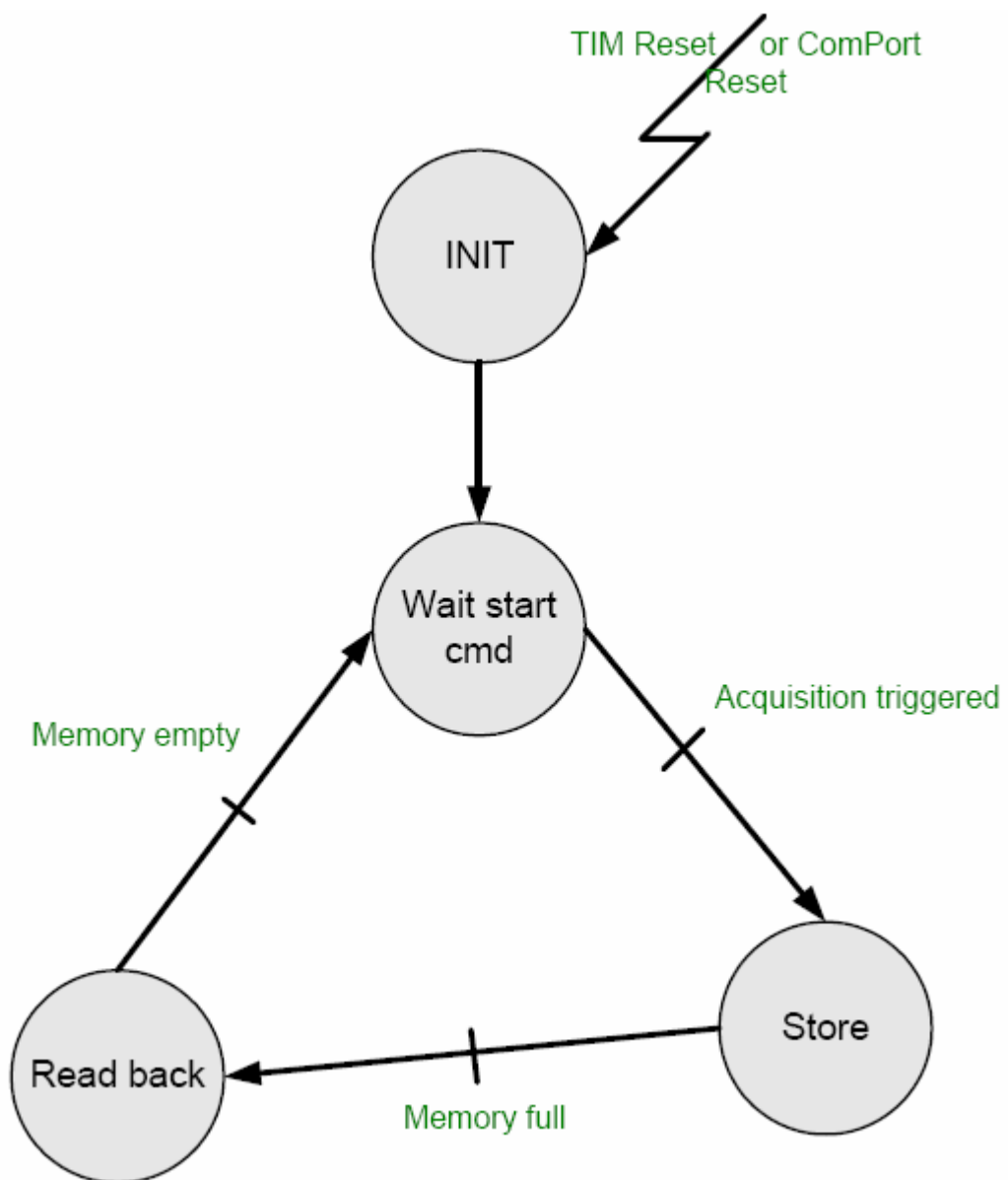

Figure 21. SMT381-VP Firmware State Diagram.

4.2 Configuring the FPGA

The default for the FPGA configuration mode is using ComPort3. Configuring the FPGA from ComPort 3 makes it possible not to have to use a JTAG cable. Having a direct ComPort link enhances debugging and testing and therefore reduces the products time to market.

The configuration data can be downloaded into a DSP TIM module external memory (SMT6001) along with the DSP application, or configuration data can be sent from a PC application using a Sundance carrier with a DSP host (SMT6500).

The bitstream is presented on ComPort 3 and the microcontroller embedded on the SMT381-VP provides the mechanism to deliver it to the Virtex-II Pro device (configuration takes about 35 seconds and the process is similar to the configuration of the SMT398. For more into refer to the SMT398 User Manual).

After configuration the ComPort is available to the FPGA for data transfers.

4.3 Setting up the FPGA

- Configure the FPGA over ComPort 3 like described above
- Initialize the SMT381-VP registers with the required values. See Control Register Settings section underneath for the description of these registers
- Store data in the memory on the SMT381-VP by writing it over the SHB bus.
- The SMT381-VP is waiting for a trigger to start transferring data to the DAC. This command can come either from the external trigger connectors, or from ComPort 3 (see transfer trigger register section for more information).
- Once it receives a trigger command, the SMT381-VP will read data from the memory and pass it on to the DAC.

5 Control Register Settings

The Control Registers in the SMT381 example firmware control the complete functionality of the SMT381-VP. These Control Registers are setup via ComPort 3. The settings of the DAC, the trigger settings, the clock settings, the configuration of the SHB and RSL interfaces and the internal FPGA data path settings can be configured via the Control Registers.

5.1 Control Packet Structure

The data passed on to the SMT381 over the ComPorts must conform to a certain packet structure (for compatibility with example firmware). Only valid packets will be accepted and only after acceptance of a packet will the appropriate settings be implemented. Each packet will start with a certain command indicating a write (0x1) or a read (0x2). The address to write the data payload into (or where to read from) will follow next. After the address the data will follow.

A 32-bit packet is received on ComPort3 and decoded. A write command will write data into a register. A read command will request data from the FPGA. Once the data is collected it will be transmitted over ComPort3. When issuing a read command the return value must first be received before issuing the next read command.

All maximum size of registers that can be written to or read is 16 Bits. When performing a read bits 31 downto 16 will reflect the command and address. The lower 16 bits will contain the actual data.

This structure is illustrated in the following figure:

Byte Content								
Byte	Bit 7	Bit 6	Bit 5	Bit 4	Bit 3	Bit 2	Bit 1	Bit 0
3	Cmnd 3	Cmnd 2	Cmnd 1	Cmnd 0	Address 11	Address 10	Address 9	Address 8
2	Address 7	Address 6	Address 5	Address 4	Address 3	Address 2	Address 1	Address 0
1	Data 15	Data 14	Data 13	Data 12	Data 11	Data 10	Data 9	Data 8
0	Data 7	Data 6	Data 5	Data 4	Data 3	Data 2	Data 1	Data 0

Or

31 .. 28	27 .. 24	23 .. 20	19 .. 16	15 .. 12	11 .. 8	7 .. 4	3 .. 0
Command	Address			Data MSB		Data LSB	

Figure 22. Setup Packet Structure.

The defined commands are:

Command Value	Command Description
0x0	Reserved
0x1	FPGA Write
0x2	FPGA Read
0x3	Reserved
0x4	Reserved

0x5	Reserved
0x6	Reserved
0x7	Reserved
0x8	Reserved
0x9	Reserved
0xA	Reserved
0xB	Reserved
0xC	Reserved
0xD	Reserved
0xE	Reserved
0xF	FPGA Reset

Figure 23. Packet Structure – Defined Commands.

5.2 Reading and Writing Registers

Control packets are sent to the SMT381-VP over ComPort 3. This is a bi-directional interface and data can be sent to the SMT381-VP over ComPort 3 and also received over it. ComPort 3 is used to write control information to the SMT381-VP. Data is written by sending a 'Write Packet' (Command 0x1). Data is read by first writing a 'Read Request' (Command 0x2) packet containing the address to be read over ComPort 3. The SMT381-VP will collect the required data and send a 'Read Packet' out over ComPort 3 containing the requested data. The format of a 'Read Packet' is the same as that of a write packet. (For the example firmware ComPort 3 is the designated communications port on the SMT381-VP. This ComPort may however be connected to any ComPort on the Host.)

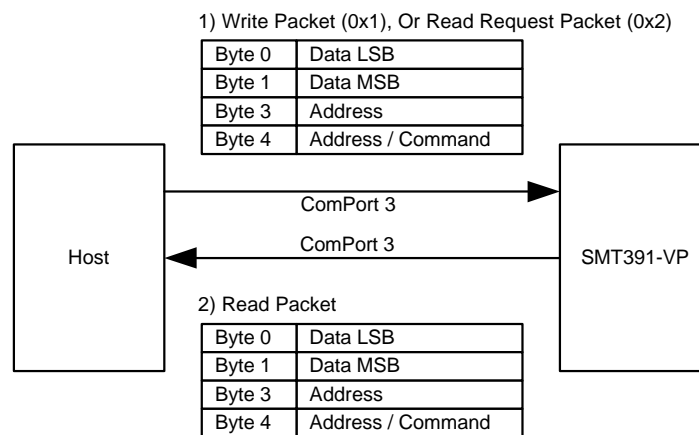

Figure 24. Control Register Read Sequence.

Example 1:

Sending 0x1001FFFF over ComPort3 from the Host to the SMT381-VP will Write, to Address 0x001, Data FFFF

Example 2:

Sending 0x2801xxxx over ComPort3 from the Host to the SMT381-VP will request a Read, from Address 0x801. Once this command is received by the SMT381-VP, the requested data will automatically be transmitted back over ComPort 3, following the same packet structure.

5.3 Memory Map

The write packets must contain the address where the data must be written to and the read packets must contain the address where the required data must be read. The following figure shows the memory map for the writable and readable Control Registers on the SMT381-VP:

Write Side		Read Side	
Address	Register	Address	Register
0x000	Reserved	0x000	FirmwareVersion
0x001	ComInScratchReg0	0x001	ComOutScratchReg0
0x002	ComInScratchReg1	0x002	ComOutScratchReg1
0x003	ShbACntrlReg	0x003	ShbAStatusReg
0x004	ShbBCntrlReg	0x004	ShbBStatusReg
0x005	ShbAComTestWordInLsb	0x005	ShbAComTestWordOutLsb
0x006	ShbAComTestWordInMsb *	0x006	ShbAComTestWordOutMsb
0x007	ShbBComTestWordInLsb	0x007	ShbBComTestWordOutLsb
0x008	ShbBComTestWordInMsb *	0x008	ShbBComTestWordOutMsb
0x009	Reserved	0x009	Reserved
0x00A	Reserved	0x00A	Reserved
0x00B	Reserved	0x00B	Reserved
0x00C	Reserved	0x00C	Reserved
0x00D	Reserved	0x00D	Reserved
0x00E	DdrACPCntrlReg	0x00E	DdrACPStatusReg
0x00F	DdrBCPCntrlReg	0x00F	DdrBCPStatusReg
0x010	DdrACPCCommand0In	0x010	Reserved
0x011	DdrACPCCommand1In	0x011	Reserved
0x012	DdrACPCCommand2In	0x012	Reserved
0x013	DdrACPCCommand3In *	0x013	Reserved
0x014	DdrACPData0In	0x014	DdrACPData0Out
0x015	DdrACPData1In	0x015	DdrACPData1Out
0x016	DdrACPData2In	0x016	DdrACPData2Out
0x017	DdrACPData3In *	0x017	DdrACPData3Out +
0x018	DdrBCPCCommand0In	0x018	Reserved
0x019	DdrBCPCCommand1In	0x019	Reserved
0x01A	DdrBCPCCommand2In	0x01A	Reserved
0x01B	DdrBCPCCommand3In *	0x01B	Reserved
0x01C	DdrBCPData0In	0x01C	DdrBCPData0Out
0x01D	DdrBCPData1In	0x01D	DdrBCPData1Out
0x01E	DdrBCPData2In	0x01E	DdrBCPData2Out

0x01F	DdrBCPData3In *	0x01F	DdrBCPData3Out +
0x020	Reserved	0x020	Smt338AirTempReg
0x021	Reserved	0x021	Smt338DiodeTempReg
0x022	Reserved	0x022	Smt338SerialNoA
0x023	Reserved	0x023	Smt338SerialNoB
0x024	Reserved	0x024	Smt338SerialNoC
0x025	Reserved	0x025	Smt338SerialNoD
0x026	Reserved	0x026	Reserved
0x027	Reserved	0x027	Reserved
0x028	Reserved	0x028	DaughterCardAirTempReg
0x029	Reserved	0x029	DaughterCardDiodeTempReg
0x02A	Reserved	0x02A	DaughterCardSerialNoA
0x02B	Reserved	0x02B	DaughterCardSerialNoB
0x02C	Reserved	0x02C	DaughterCardSerialNoC
0x02D	Reserved	0x02D	DaughterCardSerialNoD
0x02E	Reserved	0x02E	Reserved
0x02F	Reserved	0x02F	Reserved
0x030	Reserved	0x030	Reserved
0x031	Reserved	0x031	Reserved
0x032	Reserved	0x032	Reserved
0x033	Reserved	0x033	Reserved
0x034	Reserved	0x034	Reserved
0x035	Reserved	0x035	Reserved
0x036	Reserved	0x036	Reserved
	DAC Module Specific		DAC Module Specific
0x800	Reserved	0x800	Reserved
0x801	Reserved	0x801	Reserved
0x802	Reserved	0x802	Reserved
0x803	Reserved	0x803	Reserved
0x804	Reserved	0x804	Reserved
0x805	Reserved	0x805	Reserved
0x806	Reserved	0x806	Reserved
0x807	Reserved	0x807	Reserved
0x808	Reserved	0x808	Reserved
0x809	Reserved	0x809	Reserved
0x80A	Reserved	0x80A	Reserved
0x80B	Reserved	0x80B	Reserved
0x80C	Reserved	0x80C	Reserved
0x80D	Reserved	0x80D	Reserved
0x80E	Reserved	0x80E	Reserved
0x80F	Reserved	0x80F	Reserved

* Write Data Valid pulse is generated when this register is written to.

+ A pre-read is generated on the first read. A second read is required to read the real data.

Table 3. Register Memory Map (DAC registers not yet fixed in firmware)

For registers larger than 16 bits with an LSB and MSB part always write the LSB part first and then the MSB.

5.4 Register Descriptions

5.4.1 The Reset Register

As with normal register reading (command 0x2) and writing (command 0x1), there is a command defined for reset. This is command 0xF. The reset command will write to a reset register. Writing 0x0001 to it will keep the FPGA in reset, and writing 0x0000 to it will take the FPGA out of reset. This register is at address 0x000.

31 .. 28	27 .. 24	23 .. 20	19 .. 16	15 .. 12	11 .. 8	7 .. 4	3 .. 0
Command	Address			Data MSB		Data LSB	
0xF	0x000			0x00		0x00 – Not in Reset	
0xF	0x000			0x00		0x01 – FPGA in Reset	

Figure 25. Reset Register (Write Only).

5.4.2 Firmware Version Register (Read Add 0x000)

A read from address 0x000 will display the firmware version register. The value of this register is hard coded during VHDL compiles and must be stepped for each new version of the firmware. Even though 32 bits are read over the ComPort, the firmware version register is a 16 bit register (16 least significant bits of the returned value).

Read Request Format:

31 .. 28	27 .. 24	23 .. 20	19 .. 16	15 .. 12	11 .. 8	7 .. 4	3 .. 0
Command	Address			Data MSB		Data LSB	
0x2	0x000			xx		xx	

Read Response Format:

31 .. 28	27 .. 24	23 .. 20	19 .. 16	15 .. 12	11 .. 8	7 .. 4	3 .. 0
Command	Address			Data MSB		Data LSB	
0x2	0x000			Firmware Version		Firmware Version	

Figure 26. Firmware Version Register (Read Only).

5.4.3 Temperature Registers (Read Add 0x020, 0x021, 0x028,0x029)

There are four temperature registers. Each register is 16 bits long. When the bit value of the register is converted to a decimal number, that number is the temperature in degrees Celsius.

Read Request Format:

31 .. 28	27 .. 24	23 .. 20	19 .. 16	15 .. 12	11 .. 8	7 .. 4	3 .. 0
Command	Address			Data MSB		Data LSB	
0x2	0x020 (Smt338AirTempReg) (1)			xx		xx	
0x2	0x021 (Smt338DiodeTempReg) (2)			xx		xx	
0x2	0x028 (DaughterCardAirTempReg) (3)			xx		xx	
0x2	0x029 (DaughterCardDiodeTempReg) (4)			xx		xx	

- (1) - SMT338-VP Air Temperature on Top of PCB
- (2) - SMT338-VP FPGA temperature on Bottom of PCB
- (3) - SMT381 Air Temperature on Bottom of PCB
- (4) - SMT381 ADC temperature on Top of PCB (Not implemented)

Read Response Format:

31 .. 28	27 .. 24	23 .. 20	19 .. 16	15 .. 12	11 .. 8	7 .. 4	3 .. 0
Command	Address			Data MSB		Data LSB	
0x2	0x020			SMT338-VP		Air Temperature	
0x2	0x021			SMT338-VP		Diode Temperature	
0x2	0x028			SMT381		Air Temperature	
0x2	0x029			SMT381		Diode Temperature	

Figure 27. Temperature Registers (Read Only).

5.4.4 Serial Number Registers (Read Add 0x022 – 0x025 and 0x02A – 0x02D)

There is a unique silicon serial number IC on both the SMT338-VP and the SMT381. Each serial number is 64 bits long and is thus requires four 16 bit registers to store the value.

Read Request Format:

31 .. 28	27 .. 24	23 .. 20	19 .. 16	15 .. 12	11 .. 8	7 .. 4	3 .. 0
Command	Address			Data MSB		Data LSB	
0x2	0x022 (Smt338SerialNoA)			xx		xx	
0x2	0x023 (Smt338SerialNoB)			xx		xx	
0x2	0x024 (Smt338SerialNoC)			xx		xx	
0x2	0x025 (Smt338SerialNoD)			xx		xx	
0x2	0x02A (DaughterCardSerialNoA)			xx		xx	
0x2	0x02B (DaughterCardSerialNoB)			xx		xx	
0x2	0x02C (DaughterCardSerialNoC)			xx		xx	
0x2	0x02D (DaughterCardSerialNoD)			xx		xx	

Figure 28. Serial Number Registers (Read Only).

Read Response Format:

31 .. 28	27 .. 24	23 .. 20	19 .. 16	15 .. 12	11 .. 8	7 .. 4	3 .. 0
Command	Address			Data MSB		Data LSB	
0x2	0x022			SMT338-VP Serial No		Byte A	
0x2	0x023			SMT338-VP Serial No		Byte B	
0x2	0x024			SMT338-VP Serial No		Byte C	
0x2	0x025			SMT338-VP Serial No		Byte D	
0x2	0x02A			SMT381 Serial No		Byte A	
0x2	0x02B			SMT381 Serial No		Byte B	
0x2	0x02C			SMT381 Serial No		Byte C	
0x2	0x02D			SMT381 Serial No		Byte D	

Figure 29. Serial Number Registers Cont. (Read Only).

5.4.5 DAC Clock Source Registers (Write Add 0x801)

The A and B channels of the DAC can receive a clock from the on-board VCO, the on-board clock synthesizer, or from an external clock (RF or ECL). The following table shows the different combinations for setting up the SMT381 clock tree.

Register Value	A Channel Clock Source	B Channel Clock Source
0x0000	On-board VCO	On-board VCO
0x0001	On-board Clock Synthesizer	On-board Clock Synthesizer
0x0002	External ECL Clock	External ECL Clock
0x0003	External ECL Clock	External ECL Clock
0x0004	On-board VCO	On-board VCO
0x0005	On-board Clock Synthesizer	On-board Clock Synthesizer
0x0006	External RF Clock	External RF Clock
0x0007	External RF Clock	External RF Clock

Figure 30. Clock Source Selection Table (Write Only).

31 .. 28	27 .. 24	23 .. 20	19 .. 16	15 .. 12	11 .. 8	7 .. 4	3 .. 0
Command	Address			Data MSB		Data LSB	
0x1	0x801			0x00		Clock Register Value	

Figure 31. Clock Source Register (Write Only).

5.4.6 Clock Synthesizer Setup Register (Write Add 0x800)

This register sets up the frequency of the clock synthesizer on the SMT381. Any write operation to this register will trigger the clock synthesizer interface control logic to initialize the clock synthesizer with its new value.

31 .. 28	27 .. 24	23 .. 20	19 .. 16	15 .. 12	11 .. 8	7 .. 4	3 .. 0
Command	Address			Data MSB		Data LSB	
0x1	0x800			Data		Data	

Figure 32. Clock Synthesizer Setup Register (Write Only).

For a detailed description of the configurable bits in the Clock Synthesizer register please refer to the “Clock Synthesizer” section under “Firmware Building Blocks” at the end of this document.

5.4.7 PLL Setup Registers (Write Add 0x802 – 0x809)

These registers set up the frequency of the PLL circuit on the SMT381. There are two sets of registers – one set for setting up the IF side of the PLL, and the other set for setting up the RF side of the PLL. The IF side is unconnected, while the RF side is connected to a 600 – 1200 MHz VCO circuit which is divided by two before entering the DAC at a frequency of 300 – 600MHz. All registers must be initialized, and only when writing to the final register will both the IF and RF side be configured to their new values.

31 .. 28	27 .. 24	23 .. 20	19 .. 16	15 .. 12	11 .. 8	7 .. 4	3 .. 0
Command	Address			Data MSB		Data LSB	
0x1	0x802			Not Used		Not Used	
0x1	0x803			Not Used		Not Used	
0x1	0x804			Not Used		Not Used	
0x1	0x805			Not Used		Not Used	
0x1	0x806			Smt381PII_RfR_Reg1		Smt381PII_RfR_Reg1	
0x1	0x807			Smt381PII_RfR_Reg2		Smt381PII_RfR_Reg2	
0x1	0x808			Smt381PII_RfN_Reg1		Smt381PII_RfN_Reg1	
0x1	0x809			Smt381PII_RfN_Reg2		Smt381PII_RfN_Reg2	

Figure 33. PLL Setup Registers (Write Only).

For a detailed description of the configurable bits in the PLL registers please refer to the “PLL Configuration” section under “Firmware Building Blocks” at the end of this document.

5.4.8 DAC Setup Registers (Write Add 0x900 – 0x905)

These registers configure the internal functionality of the DAC on the SMT381. There are six registers – 4 data registers an address register and setup register. The address and setup registers must be set up before the data registers. Once the data registers are written to the data, address and setup information contained in all the registers will be transferred to the DAC over a serial interface.

31 .. 28	27 .. 24	23 .. 20	19 .. 16	15 .. 12	11 .. 8	7 .. 4	3 .. 0
Command	Address			Data MSB		Data LSB	
0x1	0x900			Smt381SetupData		Smt381SetupData	
0x1	0x901			Smt381DacAddress		Smt381DacAddress	
0x1	0x902			Smt381DacData(LSB)		Smt381DacData(LSB)	
0x1	0x903			Smt381DacData		Smt381DacData	
0x1	0x904			Smt381DacData		Smt381DacData	
0x1	0x905			Smt381DacData(MSB)		Smt381DacData(MSB)	

Figure 34. DAC Setup Registers (Write Only).

For a detailed description of the configurable bits in the DAC registers please refer to the “DAC Configuration” section under “Firmware Building Blocks” at the end of this document.

6 PCB Layout

6.1 SMT381 PCB View

The following figure shows the Final Placement of Components for the SMT381 PCB layout.

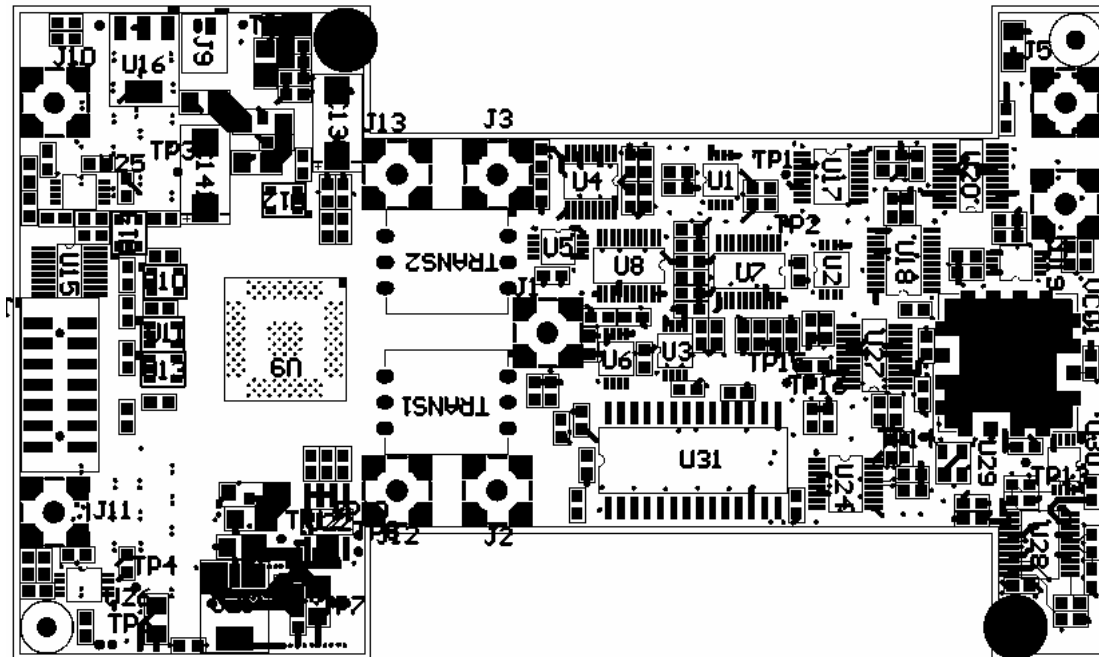

Figure 35. SMT 381 PCB layout - TOP.

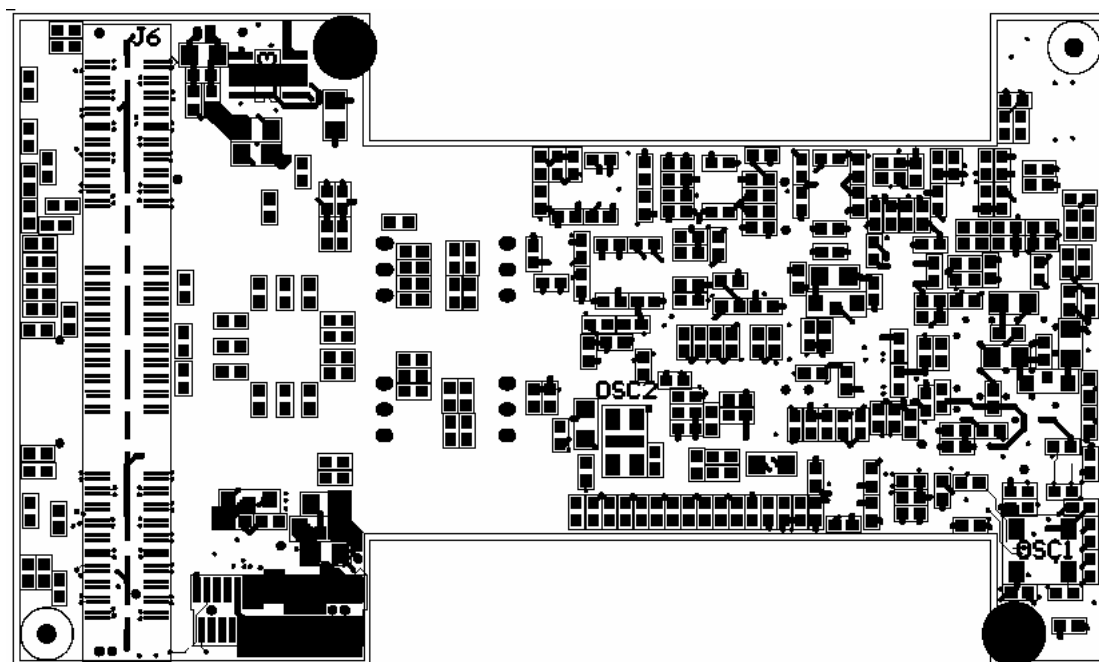

Figure 36. SMT 381 PCB layout – BOTTOM.

6.2 Assembly Drawings

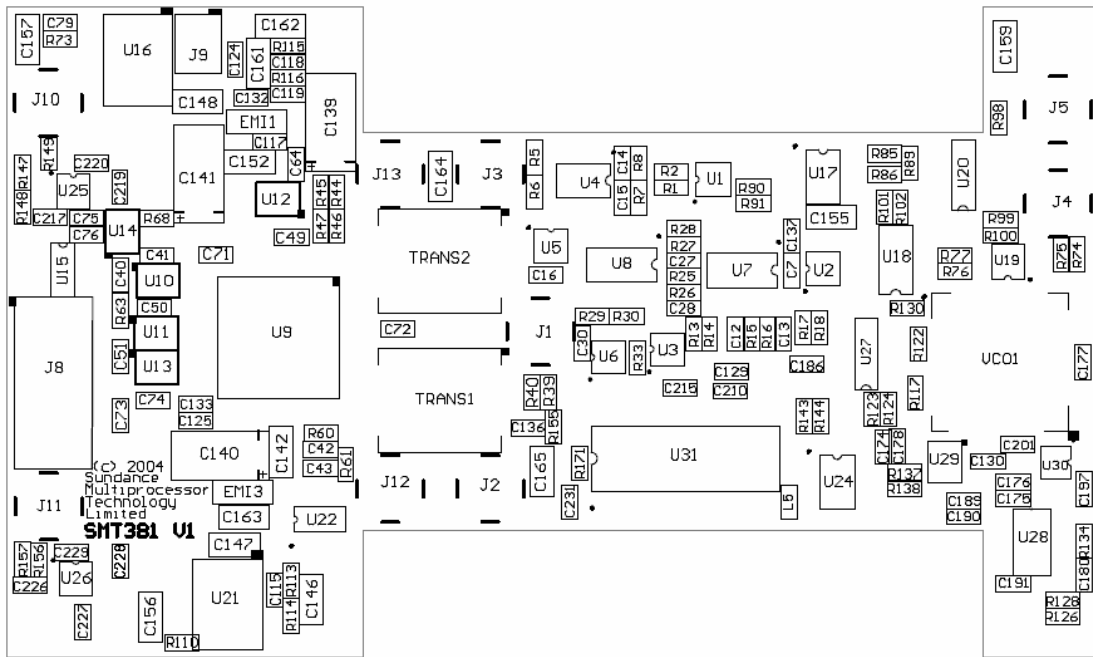

Figure 37. SMT381 Top Assembly Drawings.

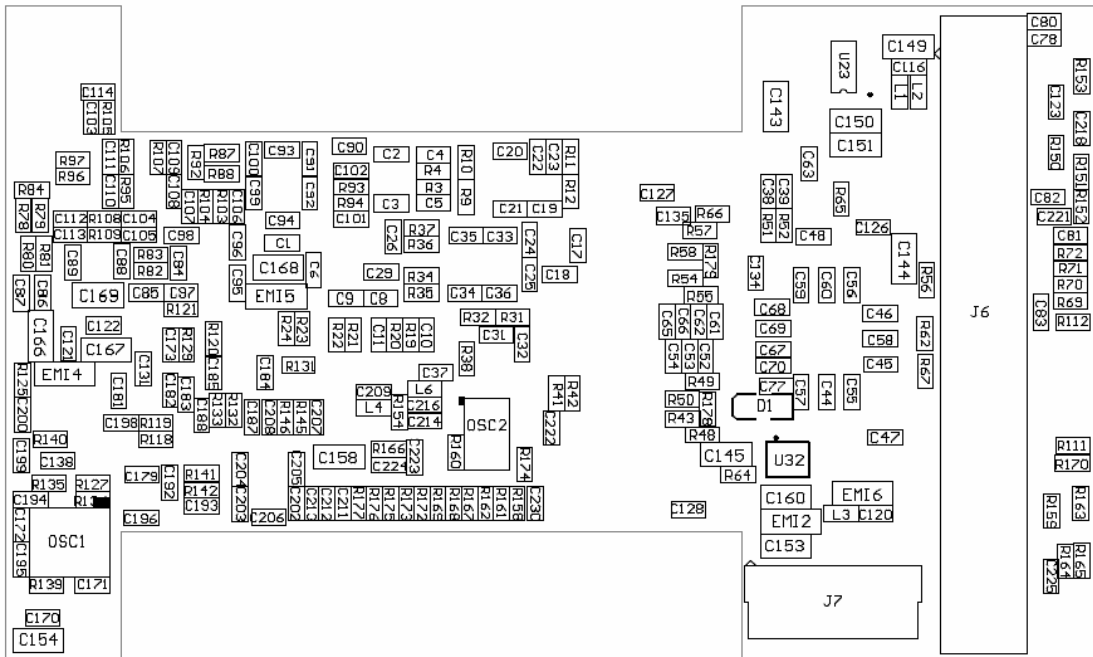

Figure 38. SMT381 Bottom Assembly Drawings.

Component descriptions:

- U1 - DUAL LVTTTL to LVPECL CONVERTER
- U2 - DUAL LVTTTL to LVPECL CONVERTER
- U3 - DUAL LVTTTL to LVPECL CONVERTER

U4 - ECL /2 /4 /8 CLOCK GENERATOR
U5 - ECL 1:2 DIFFERENTIAL FANOUT BUFFER
U6 - ECL 1:2 DIFFERENTIAL FANOUT BUFFER
U7 - ECL 2:1 INPUT 1:5 CLOCK BUFFER
U8 - ECL DUAL 2:1 MULTIPLEXER
U9 - DUAL 14-BIT DAC
U10 - FAIRSEMI TRI-BUFFER SOT-23
U11 - FAIRSEMI TRI-BUFFER SOT-23
U12 - FAIRSEMI TRI-BUFFER SOT-23
U13 - FAIRSEMI TRI-BUFFER SOT-23
U14 - FAIRSEMI TRI-BUFFER SOT-23
U15 - MAXIM LOCAL / REMOTE DIODE TEMP SENSE SMBUS
U16 - MAXIM 1-WIRE SERIAL NO SOT-223
U17 - ECL /2 /4 /8 CLOCK GENERATOR
U18 - ECL DUAL 2:1 MULTIPLEXER
U19 - ECL RECEIVER / DRIVER
U20 - MAXIM DUAL ECL 500ps COMPARATOR
U21 - TI 1.5A LOW NOISE LDO
U22 - TI 2A POWER DISTRIBUTION SWITCH
U23 - TI 0.5A NEGATIVE LDO
U24 - ECL /2 /4 /8 CLOCK GENERATOR
U25 - ECL RECEIVER / DRIVER
U26 - ECL RECEIVER / DRIVER
U27 - MAXIM DUAL ECL 500ps COMPARATOR
U28 - DUAL 2.5GHZ/600MHZ PLL
U29 - MINI-CIRCUITS 50 OHM FIXED ATTENUATOR
U30 - NATIONAL DUAL AUDIO OP-AMP MIN12V
U31 - 25 TO 400 MHZ CLOCK SYNTHESIZER
U32 - 1.2V Voltage Reference

J1 - MMBX STRAIGHT PCB JACK (FEMALE) – DAC clock output.
J2 - MMBX STRAIGHT PCB JACK (FEMALE) – Channel A analog + output.
J3 - MMBX STRAIGHT PCB JACK (FEMALE) – Channel B analog + output.
J4 - MMBX STRAIGHT PCB JACK (FEMALE) – Ext ECL clock input
J5 - MMBX STRAIGHT PCB JACK (FEMALE) – Ext RF clock input
J6 - 0.5mm Pitch Differential Pair Connector QSH(-DP) Series
J7 - BKT SERIES POLARISED HEADER - 33-WAY
J8 - SMT398-PRO JTAG CONNECTOR
J9 - MOLEX 2 PIN 90DEG THP, 1.25mm FAN CONN
J10 - MMBX STRAIGHT PCB JACK (FEMALE) – Ext Trigger A
J11 - MMBX STRAIGHT PCB JACK (FEMALE) – Ext Trigger B
J12 - MMBX STRAIGHT PCB JACK (FEMALE) – Channel A analog – output.
J13 - MMBX STRAIGHT PCB JACK (FEMALE) – Channel B analog – output.

OSC1 - 3V3 OSCILLATOR 20ppm

OSC2 - ECX-64 16MHz CRYSTAL

TRANS1 - MACOM PULSE TRANSFORMER - PIN PACKAGE

TRANS2 - MACOM PULSE TRANSFORMER - PIN PACKAGE

VCO1 - UMC'S UMC SERIES VCO

6.3 SMT338-VP Assembly Drawings

The following figures show the top and bottom assembly drawings of the SMT338-VP.

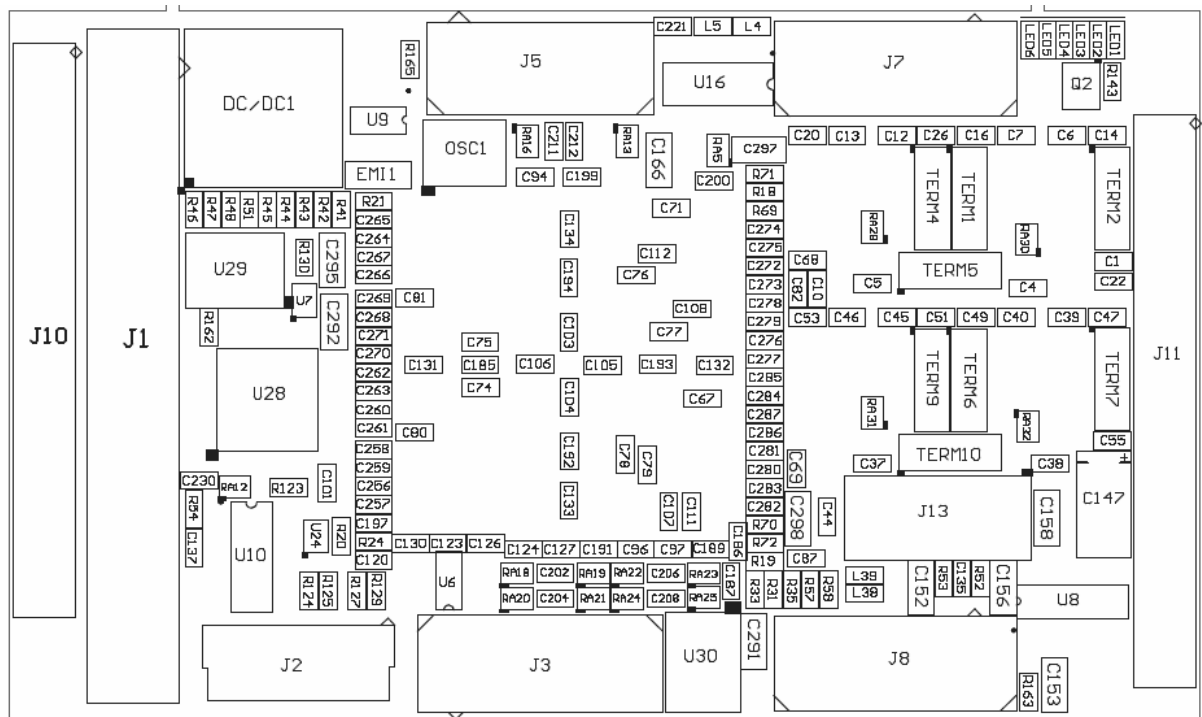

Figure 39. Main Module Top Assembly Drawing.

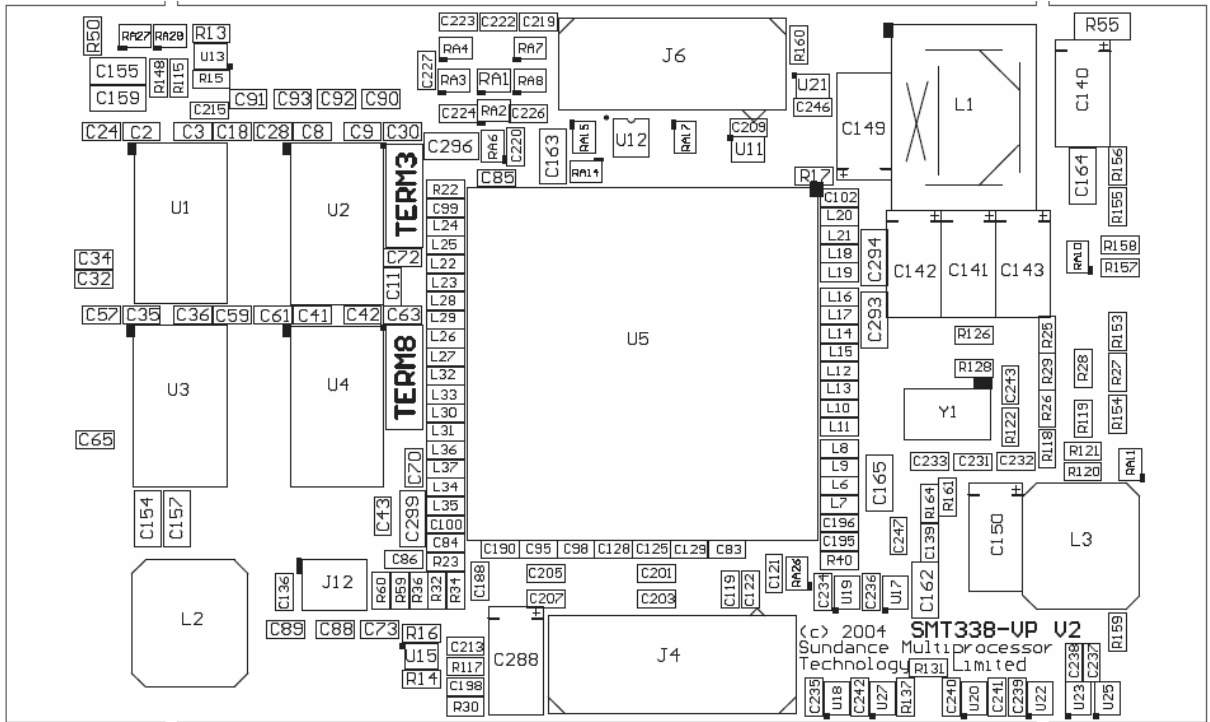

Figure 40. Main Module Bottom Assembly Drawing.

6.4 SMT381 PCB View

If the SMT381-VP is mated with a PCI carrier two PCI slots will be required for the Module + Carrier combination. If the SMT381-VP is mated with a cPCI carrier the Module + Carrier will require two cPCI slots.

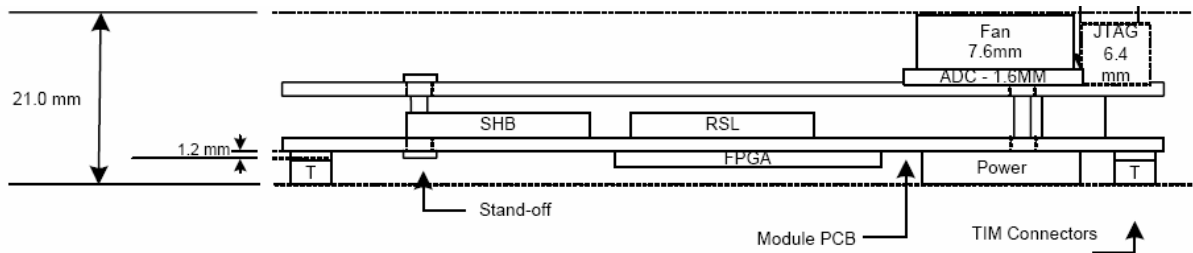

Figure 41. Side view of SMT381-VP (Height).

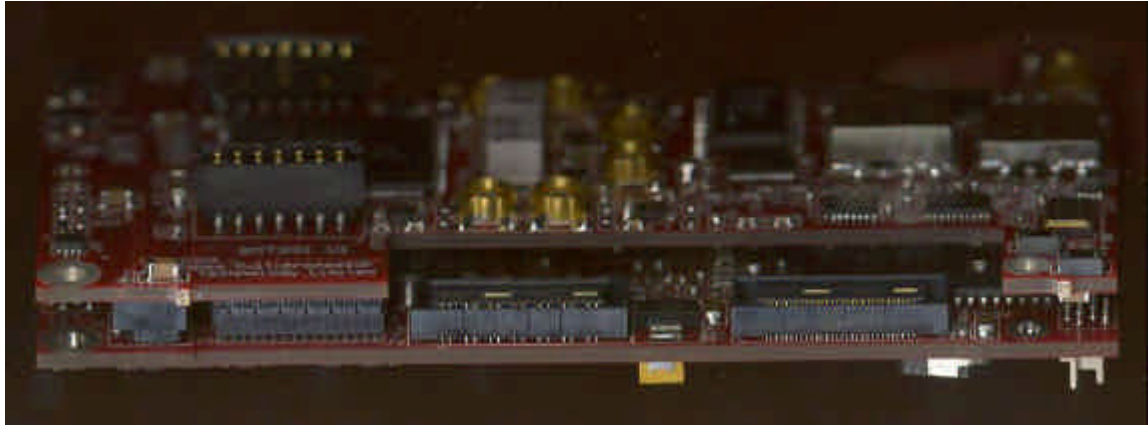

Figure 42. Side view of SMT381-VP.

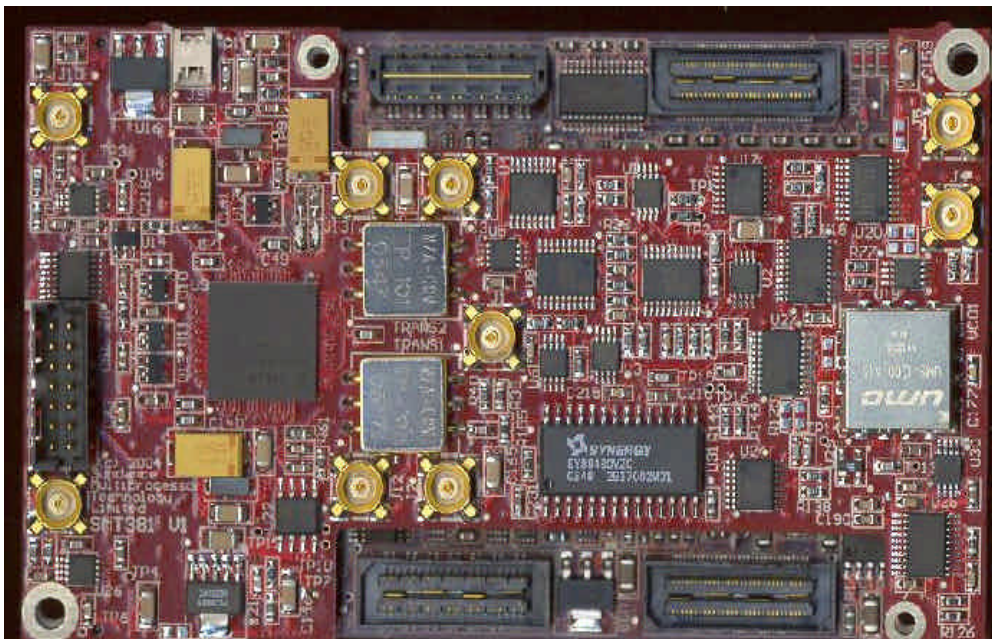

Figure 43. Top view of SMT381-VP.

The following diagram indicates the location of all the important connectors and components on the SMT381 (Rev 1) PCB.

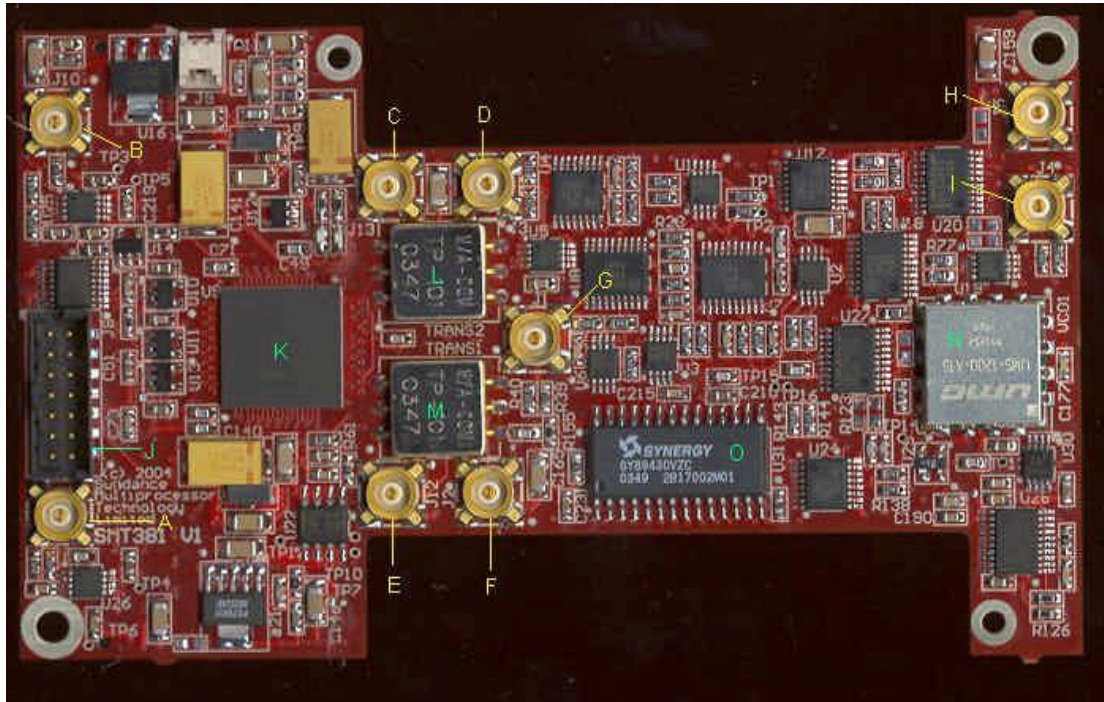

Figure 44. Connector Location on SMT381,

Diagram Ref	Pcb RefDes	Description	Notes
A	J11	External Trigger B Channel	LVPECL Signal. Positive on inside of connector. Negative on outside of connector.
B	J10	External Trigger A Channel	LVPECL Signal. Positive on inside of connector. Negative on outside of connector.
C	J13	DAC Output B Channel (neg)	Analog Signal. Signal on inside of connector. GND on outside of connector. For DC Coupling only (differential signal, split over both connectors).
D	J3	DAC Output B Channel (pos)	Analog Signal. Signal on inside of connector. GND on outside of connector. For AC Coupling (single ended), and pos side of DC coupling (differential)
E	J12	DAC Output A Channel (neg)	Analog Signal. Signal on inside of connector. GND on outside of connector. For DC Coupling only (differential signal, split over both connectors).
F	J2	DAC Output A Channel (pos)	Analog Signal. Signal on inside of connector. GND on outside of connector. For AC Coupling (single ended), and pos side of DC coupling (differential).
G	J1	DAC Test Clock Output	LVPECL output test clock. Copy of clock going to DAC. Positive on inside of connector, negative on outside of connector. Used for verification of the clock going to the DAC.
H	J5	External RF clock input	External Analog input Clock to DAC. Clock on inside of connector, DGND on the outside of connector.
I	J4	External ECL clock input	External ECL input Clock to DAC. Positive on inside of connector, negative on the outside of connector.

Table 4. Table of Connector Locations on SMT381.

Diagram Ref	Pcb RefDes	Description	Notes
J	J8	FPGA / MSP JTAG Connector	FPGA / MSP430 on SMT338-VP JTAG Chain. Only routed down to SMT338-VP. Use for easy access without having to remove the SMT381.
K	U9	Fujitsu DAC	DAC Requires heat-sink with air-flow cooling in a system setup.
L	TRANS2	M/A Com TP101 Transformer	By default the SMT381 analog input is AC coupled through a twisted pair balun transformer (differential to single ended). It is possible to change this configuration to DC coupled by taking out the transformer and inserting some resistors on the board.
M	TRANS1	M/A Com TP101 Transformer	By default the SMT381 analog input is AC coupled through a twisted pair balun transformer (differential to single ended). It is possible to change this configuration to DC coupled by taking out the transformer and inserting some resistors on the board.
N	VCO1	UMC 600 – 1200MHz VCO	System Clock for the DAC. VCO Requires heat-sink with air-flow cooling in a system setup.
O	U31	Clock Synthesizer 50 – 950MHz	Test Clock for DAC. The range of this clock is wider than the operating range of the DAC.

Table 5. Table of Component Locations on SMT381.

7 General Properties

7.1 FPGA Mounted on SMT338-VP

All FPGA interfaces on the SMT338-VP require 508 IOs. The following table is a summary of the amount of IOs available on Xilinx Virtex-II Pro devices.

	Size (mm)	XC2VP7	XC2VP20	XC2VP30	XC2VP40	XC2VP50
FF672	27 x 27	396 / 8				
FF896	31 x 31	396 / 8	556 / 8	556 / 8		
FF1152	35 x 35		564 / 8	644 / 8	692 / 12	692 / 16

Table 6. Virtex-II Pro IO Count.

By default all SMT338-VPs are assembled with VP30 devices. The example firmware is also for a VP30 FPGA. If a VP7 is mounted some of the SHB interface IOs and the DDR SDRAM memory interface will be lost.

7.2 Design Resource Usage

The following table is a summary of the FPGA resources used by the demo design that comes with the SMT381-VP (compiled for a VP30 device).

Resource	Utilization	Percentage
Number of External DIFFMs	37 out of 276	13%
Number of External DIFFSs	37 out of 276	13%
Number of External IOBs	266 out of 556	47%
Number of LOCed External IOBs	249 out of 266	93%
Number of RAMB16s	72 out of 136	52%
Number of SLICES	6640 out of 13696	48%
Number of BUFGMUXs	13 out of 16	81%
Number of DCMs	7 out of 8	87%

Table 7. Virtex-II Pro Device Utilization Summary.

7.3 Power Supply

The following voltages are required by the SMT381 and must be supplied over the daughter card power connector.

Voltage	Current Required
D+3V3_IN	2.0 A
D+5V0_IN	500 mA
D+12V0_IN	250 mA
D-12V0_IN	250 mA
DGND	

Table 8. SMT381 Power Supply Voltages.

The following voltages are required by the SMT381-VP and must be supplied over the TIM connectors and TIM mounting hole

Voltage	Current Required
D+3V3_IN	4.0 – 6.0 A
D+5V0_IN	4.0 A
D+12V0_IN	500 mA
D-12V0_IN	500 mA
DGND	

Table 9. SMT381-VP Power Supply Voltages.

The following table lists the internal SMT381 voltages that are derived from the voltages that are provided over the daughter card power connector.

Voltage	Description
D+3V3	Derived from D+3V3_IN
D+1V8	Derived from D+3V3 on SMT381
A+3V3	Derived from D+3V3_IN
VCO+5V0	Derived from D+5V0_IN
VCO+12V0	Derived from D+12V0_IN
ECL-5V2	Derived from D-12V0_IN
AGND	Derived from DGND

Table 10. Internal Power Supply Voltages.

7.4 Module Dimensions

The following table lists the dimensions for the SMT381 and the SMT381-VP.

Description	Value
Module Dimensions (Only SMT381)	Width: 63.5 mm Length: 106.68 mm Height: 21mm (Maximum)
Module Dimensions (SMT381-VP)	Width: 63.5 mm Length: 106.68 mm Height: 21mm (Maximum)

Weight	TBD Grams (including heat sinks)
--------	----------------------------------

Table 11. SMT381-VP Dimensions.

7.5 FPGA/JTAG Connector

The connector present on the SMT381-VP is used for both the FPGA and MSP430 JTAG chain as illustrated in the following figure:

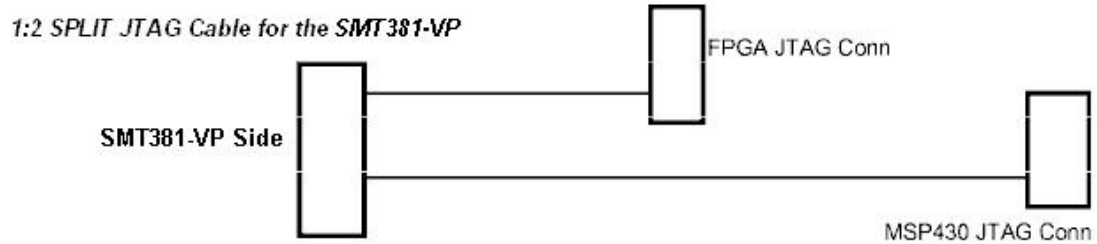

SMT381-VP Side		MSP430 JTAG Side		FPGA JTAG Side	
Connector Type: 2mm IDC Type Connector		Connector Type: 2.54mm Boxed Header or 2.54mm IDC Connector		Connector Type: 2mm IDC Type Connector	
Pin	Signal Description	Pin	Signal Description	Pin	Signal Description
1	MspTdo	1	MspTdo		
2	FpgaVRef			2	FpgaVRef
3	MspTdi	3	MspTdi		
4	FpgaTms			4	FpgaTms
5	MspTms	5	MspTms		
6	FpgaTck			6	FpgaTck
7	MspTck	7	MspTck		
8	FpgaTdo			8	FpgaTdo
9	Gnd	9	Gnd		
10	FpgaTdi			10	FpgaTdi
11	MspnTrst	11	MspnTrst		
12	Nc				
13	MspD+3V3	8	MspTest/Vpp		
14	Gnd			13	Gnd

Figure 45. FPGA/JTAG connector for the SMT381-VP.

8 System Setup

8.1 How to connect the SMT381 to SMT338-VP

The following diagram shows both the SMT338-VP and the SMT381 (together they form the SMT381-VP). There are four mounting holes on each board. The two larger holes on the SMT338-VP are the TIM mounting holes and provide the SMT338-VP with 3.3V. The two smaller holes add extra stability when the SMT381 is plugged onto the SMT338-VP (One of these holes on the SMT338-VP carries 1.5V and the other one 2.5V. These voltages are however not used on the SMT381-VP. For this reason it is thus safer to use Nylon screws).

SMT390 has the same dimensions and layout as the SMT381.

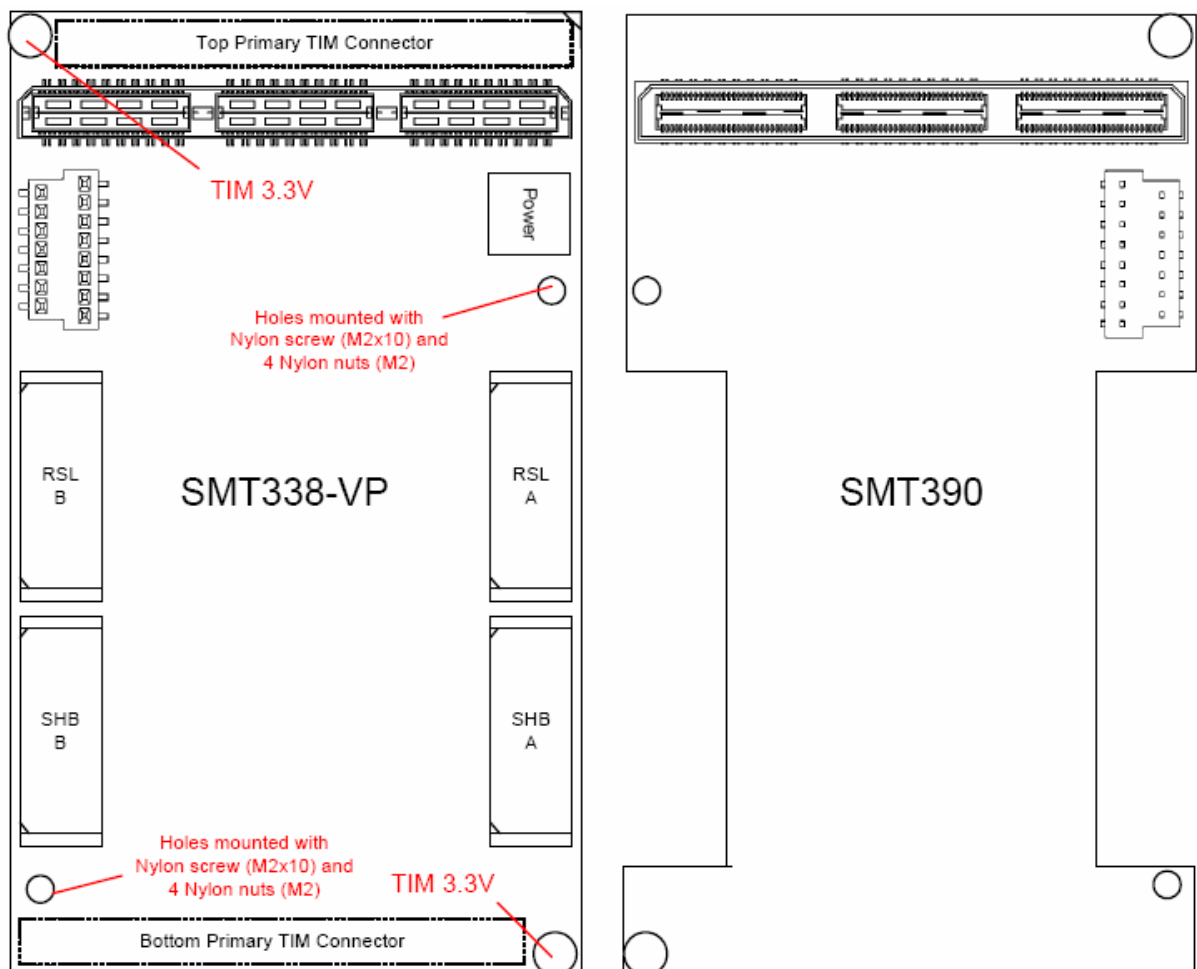

Figure 46. SMT381 to SMT338-VP Interconnection.

The following fixings are required to connect the SMT381 to the SMT338-VP:



Figure 47. Components Used to Connect the SMT381 to the SMT338-VP.

- First fit two Nylon screws (M2 x 10), pointing out (the head of the screws on the bottom side of the SMT338-VP).
- Then fit four M2 nuts on each screw.
- Place the SMT338-VP on the second TIM site (TIM 1 is for the Host) of a Sundance carrier (like the SMT310Q)
- Fit the two metal pillars to the TIM mounting holes to give the SMT338-VP 3.3V from the carrier.
- Place the SMT381-VP on top of the SMT338-VP and make sure that both modules fit firmly (the SMT381 does not need 3.3V of it's mounting hole).
- Fit two M2 nuts on the Nylon screws and two M3x4 screws in the 3.3V pillars.
- Connect ComPort3 of the SMT381-VP to an available ComPort on the Host module (eg ComPort 0).

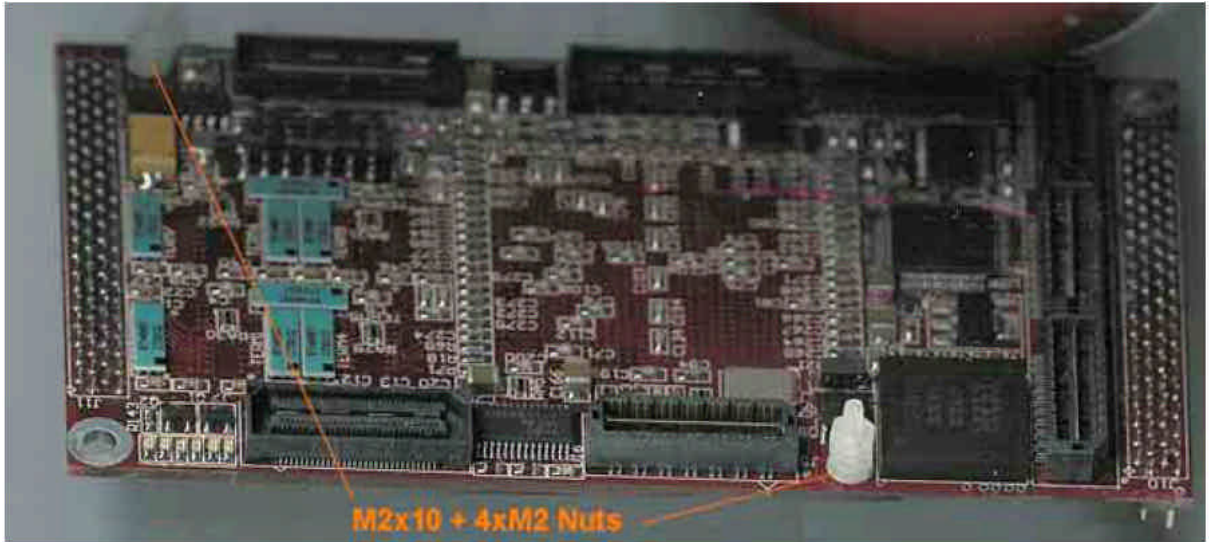

Figure 48. Fitting of Nylon Screws and Nuts to the SMT338-VP.

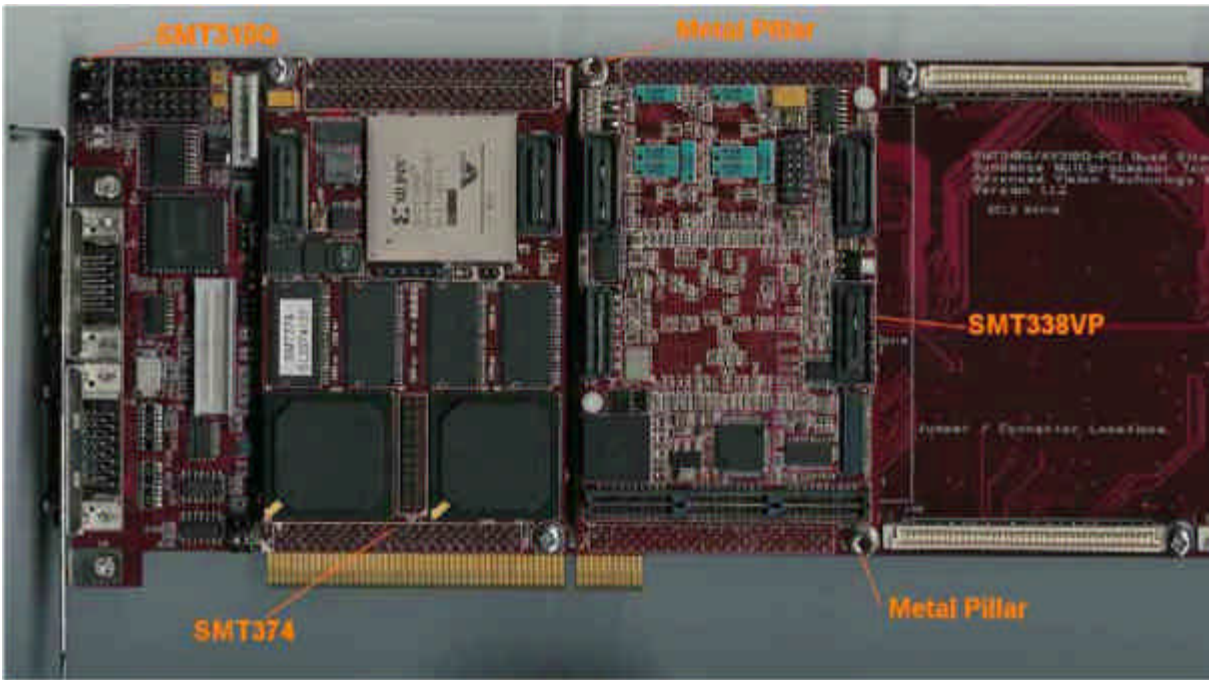

Figure 49. Securing the SMT338-VP onto a Sundance Carrier.

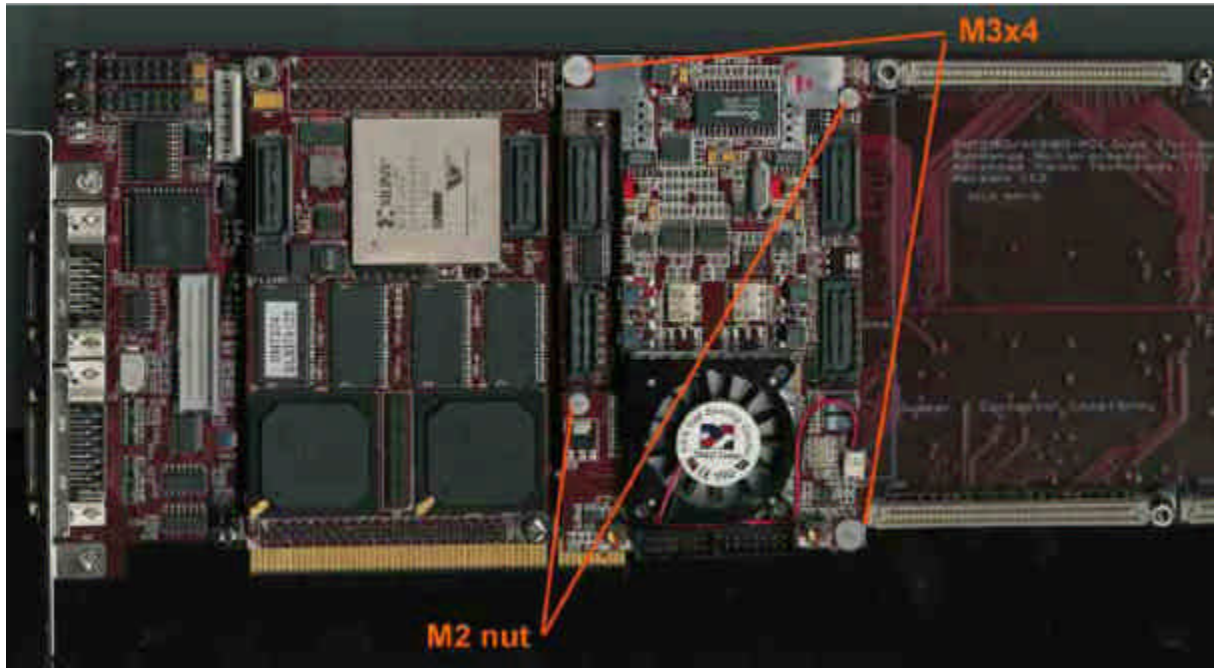

Figure 50. Connecting the SMT381 to the SMT338-VP.

9 Module Performance

9.1 Introduction

This section shows data captures from an SMT381-VP. The first set of captures were done using the LVDS data interface to clock data to the DAC. The second set uses the internal waveform memory to generate the analog output. In Appendix A at the end of this document the procedure for setting up the waveform is described.

9.2 LVDS Data interface

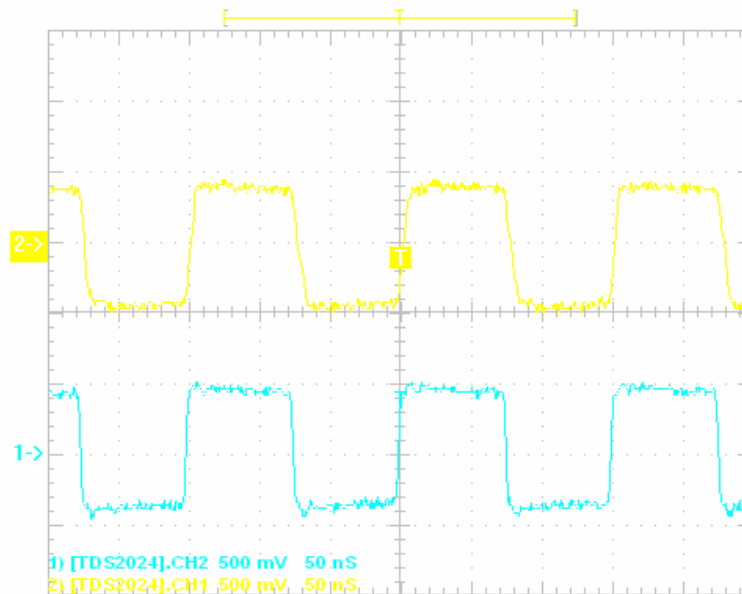

Figure 51. Time View Captures of LVDS Interface Data.

	[TDS2024].Data.Waveforms.CH 1		[TDS2024].Data.Waveforms.CH 2	
Measurement Method	Automatic		Automatic	
Measurement	Value	Units	Value	Units
Frequency	6.6357M	Hz	6.6412M	Hz
Pos. Pulse Width	75.900n	S	75.800n	S
Neg. Pulse Width	74.800n	S	74.775n	S
Rise Time	2.5000n	S	42.960n	S
Fall Time	2.4600n	S	2.7800n	S
Pos. Duty Cycle	503.65m	%	503.40m	%
Neg. Duty Cycle	496.35m	%	496.60m	%
Pos. Overshoot	95.238m	%	73.171m	%
Neg. Overshoot	71.429m	%	97.561m	%
Peak to Peak	980.00m	V	960.00m	V
Amplitude	840.00m	V	820.00m	V
High	400.00m	V	380.00m	V
Low	-440.00m	V	-440.00m	V
Maximum	480.00m	V	440.00m	V
Minimum	-500.00m	V	-520.00m	V
Mean	-16.647m	V	-132.05u	V
Cycle Mean	-13.656m	V	17.419m	V
RMS	410.90m	V	375.30m	V
BurstWidth	451.60n	S	451.85n	S
Period	150.70n	S	150.58n	S
Energy	84.387n		70.398n	
CEnergy	25.626n		19.080n	
ACRMS	410.56m	V	375.30m	V
CRMS	412.37m	V	355.97m	V

Figure 52. Measurements of Time View Capture.

9.3 Waveform Memory

In the following captures the waveform memory is set up for a cyclic run of 8 samples per channel and a sinus wave programmed into the memory. One complete cycle of the wave is loaded into the memory, resulting in a waveform being generated at $1/8^{\text{th}}$ of the sample frequency. The DAC sample frequency is double that of the clock supplied to the DAC. So for eg if a 500MHz clock is given to the DAC with the waveform memory initialized as described above the DAC sample frequency will be 1000MHz and the generated wave will be 125MHz (1000MHz divided by 8).

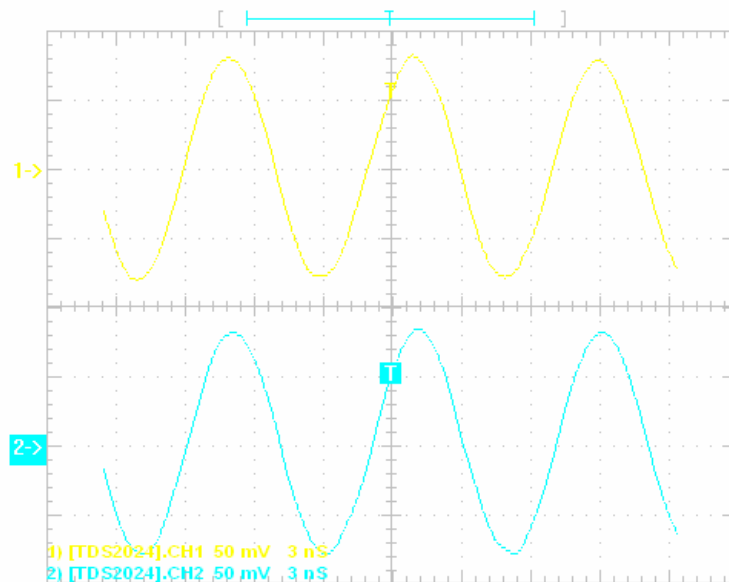

Figure 53. Waveform Memory - Time View Capture – 1000MHz sample frequency (500MHz VCO Clock) – 125MHz analog output.

	✓ [TDS2024].Data.Waveforms.CH 1	✓ [TDS2024].Data.Waveforms.CH 2
Measurement Method	Automatic	
Measurement	Value	Units
Frequency	125.31M	Hz
Pos. Pulse Width	4.0100n	S
Neg. Pulse Width	3.9700n	S
Rise Time	2.3460n	S
Fall Time	2.3260n	S
Pos. Duty Cycle	502.51m	%
Neg. Duty Cycle	497.49m	%
Pos. Overshoot	25.974m	%
Neg. Overshoot	12.987m	%
Peak to Peak	160.00m	V
Amplitude	154.00m	V
High	78.000m	V
Low	-78.000m	V
Maximum	82.000m	V
Minimum	-78.000m	V
Mean	-1.4406m	V
Cycle Mean	508.77u	V
RMS	55.086m	V
BurstWidth	19.990n	S
Period	7.9800n	S
Energy	75.831p	
CEnergy	24.371p	
ACRMS	55.067m	V
CRMS	55.264m	V

Figure 54. Measurements of Capture – 1000MHz sample frequency (500MHz VCO Clock) – 125MHz analog output.

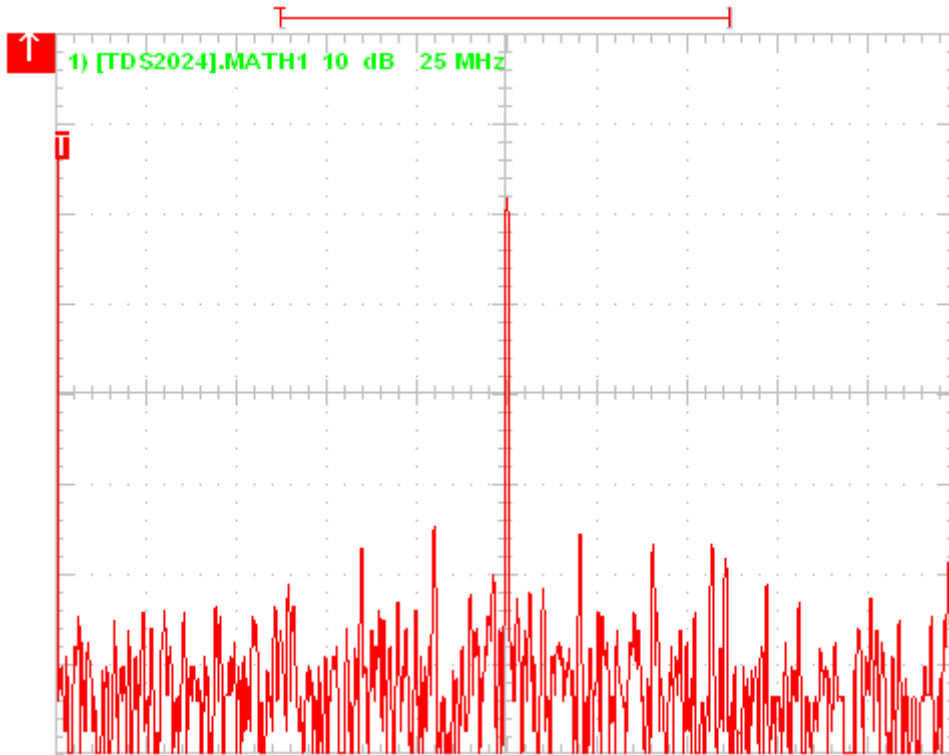

Figure 55. Waveform Memory - FFT – 1000MHz sample frequency (500MHz VCO Clock) – 125MHz analog output – Channel A.

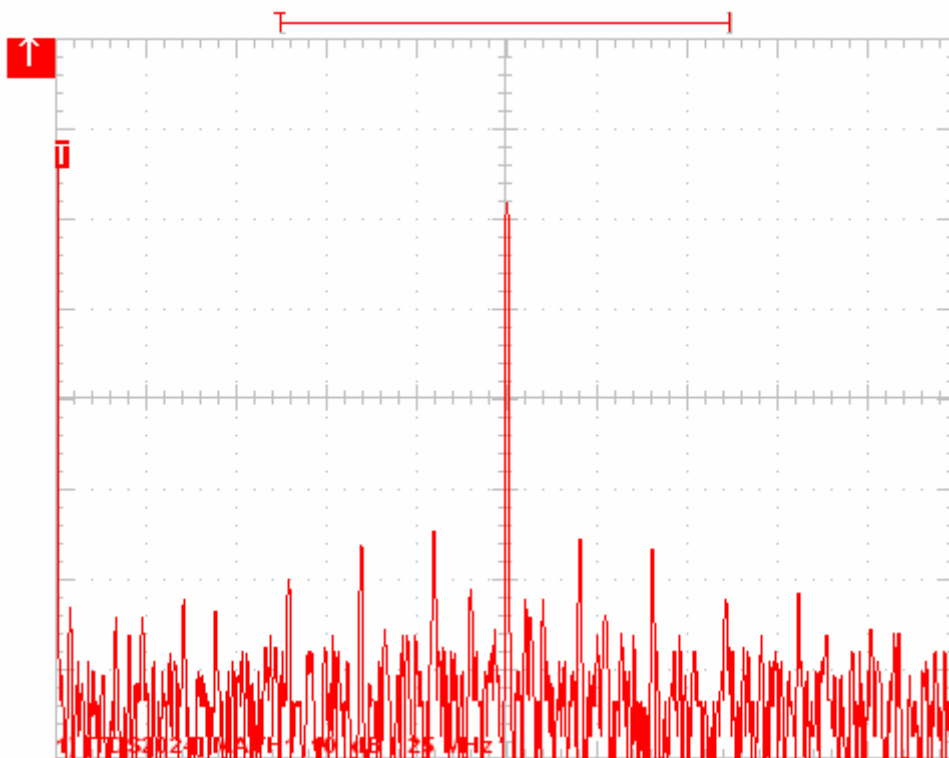

Figure 56. Waveform Memory - FFT – 1000MHz sample frequency (500MHz VCO Clock) – 125MHz analog output – Channel B.

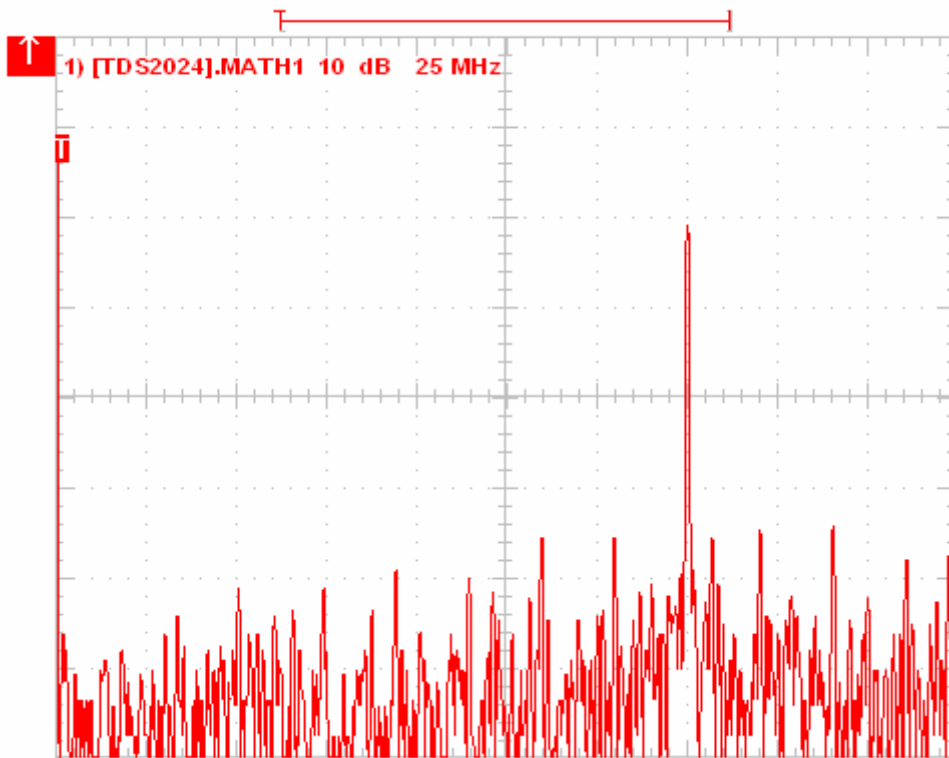

Figure 57. Waveform Memory - FFT – 1400MHz sample frequency (700MHz Synthesizer Clock) – 175MHz analog output – Channel A.

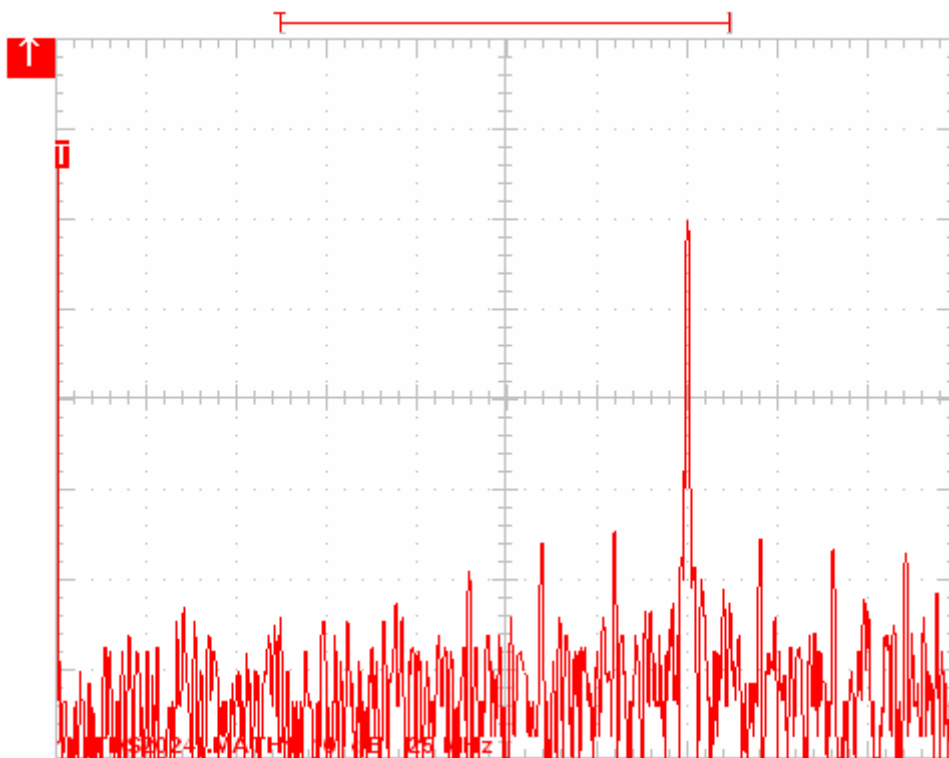

Figure 58. Waveform Memory - FFT – 1400MHz sample frequency (700MHz Synthesizer Clock) – 175MHz analog output – Channel B.

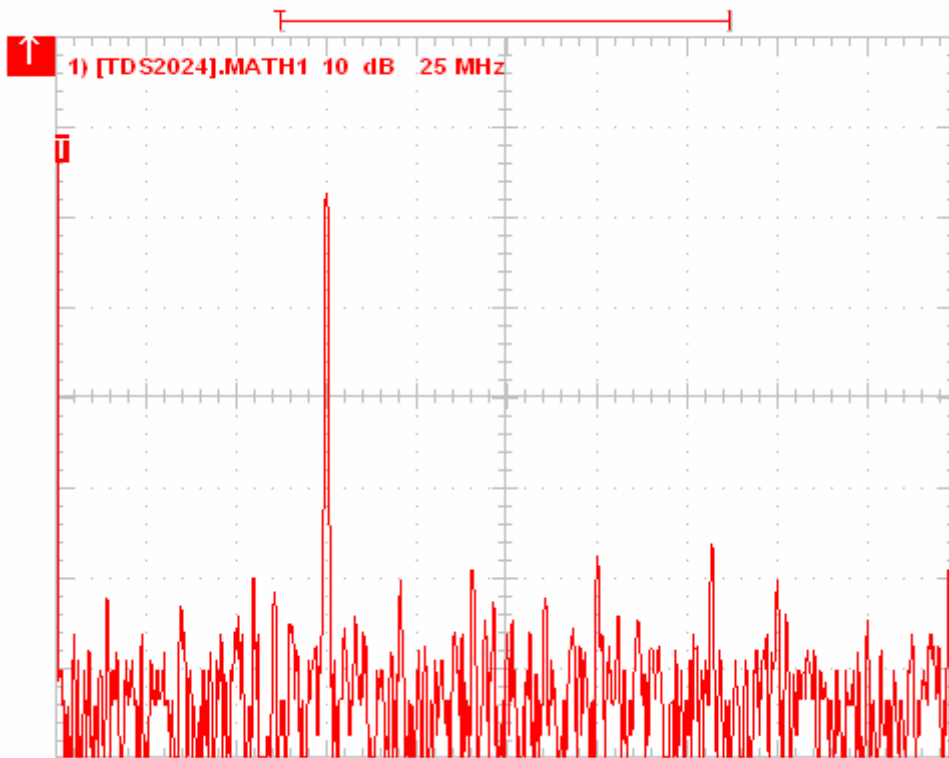

Figure 59. Waveform Memory - FFT – 600MHz sample frequency (300MHz VCO Clock) – 75MHz analog output – Channel A.

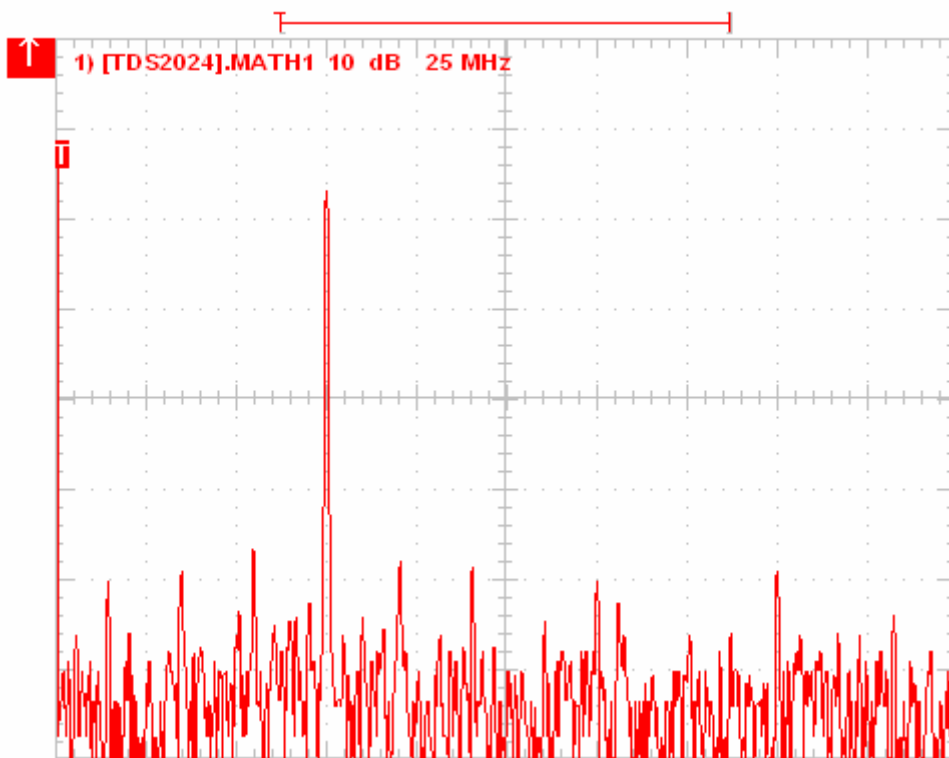

Figure 60. Waveform Memory - FFT – 600MHz sample frequency (300MHz VCO Clock) – 75MHz analog output – Channel B.

10 Firmware Building Blocks

10.1 Introduction

This section explains some of the basic low level firmware blocks that come with the example firmware design of the SMT381-VP.

10.2 Clock Synthesizer

A three wire uni-directional control interface is implemented between the FPGA of the SMT338-VP and the clock synthesizer present on the SMT381.

One 16 bit register in the SMT338-VP firmware is used for the setup of the clock synthesizer. The data word needed for the setup of the synthesizer is only 14 bits long - thus the 16 bit register is sufficient to receive data from the ComPort in one write cycle from the Host. When the ComPort receives the data for the clock synthesizer register it configures the internal firmware register accordingly and asserts the enable pin on the Clock Synthesizer State Machine.

The Clock Synthesizer State Machine generates the handshaking signals to clock data into the synthesizer. The synthesizer then generates an output clock depending on the setup given by the user. The output of the Synthesizer is a LVPECL signal.

The Clock Synthesizer register (present on the SMT338-VP firmware side) is used for the setup of the clock synthesizer on the SMT381. The table below shows the setup of this register:

Clock Control Register								
Byte	Bit 7	Bit 6	Bit 5	Bit 4	Bit 3	Bit 2	Bit 1	Bit 0
1	Do Not Care		Test Bits			Output Division		M Count
0	M Count							

Figure 61. Clock Synthesizer Register.

As the ComPort bit-stream is 16 bits long both bytes are written simultaneously. The most significant byte (Byte 1) contains the test bits, output division bits and one M count bit. The test bits selects between various internal node values and is controlled by the T[2:0] bits in the serial data stream (This feature is can be set up by the FPGA, but the value of the Test output is not read by the FPGA). The node values are shown in the table below.

T2	T1	T0	TEST	FOUT / FOUT
0	0	0	Data Out – Last Bit SR	FVCO + N
0	0	1	HIGH	FVCO + N
0	1	0	FREF	FVCO + N
0	1	1	M Counter Output	FVCO + N
1	0	0	FOUT	FVCO + N
1	0	1	LOW	FVCO + N
1	1	0	S_CLOCK + M	S_CLOCK + N
1	1	1	FOUT + 4	FVCO + N

Table 12. Clock Synthesizer Test Output.

Output division on the clock synthesizer is achieved by the two output division bits found in the first byte of the clock control register. These configurations are underneath:

N[1:0]	Output Division
0 0	2
0 1	4
1 0	8
1 1	16

Table 13. Clock Synthesizer Division Setup.

The M count bits are used to configure the clock output frequency given all the constraints set by the hardware and the clock setup bits. The nine bits can be programmed with any value from 200 – 400. All the setup bits are then used to calculate the output with the following equation.

$$F_{OUT} = \left(\frac{F_{XTAL}}{8} \right) \times \frac{M}{N}$$

FXTAL = 16MHz (external oscillator)

N = Value in decimal, set up by the division bits.

M = Value in decimal, set up by the M count bits.

Figure 62. Clock Synthesizer Frequency Calculation.

For more information refer to the Micrel datasheets of this part.

10.3 DAC serial setup

A simple 4-wire serial control interface is used to control the DAC. The serial interface uses pins SERIAL_IN, SERIAL_OUT, SERIAL_CLK and SERIAL_EN. Programmed settings are stored in a number of registers which are individually accessible using either a 7-bit (WMM Registers) or 10-bit (DAC Core Registers) address/control word. Data may be written to or read from each of these registers.

The following figure shows the function timing diagrams for a ‘write’ and ‘read’ operation.

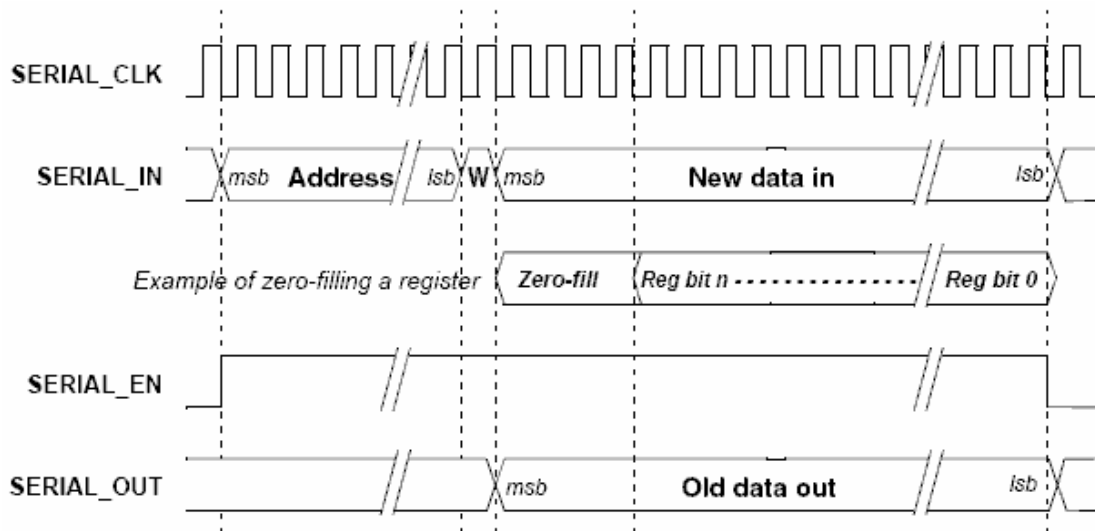

Figure 63. DAC serial write operation.

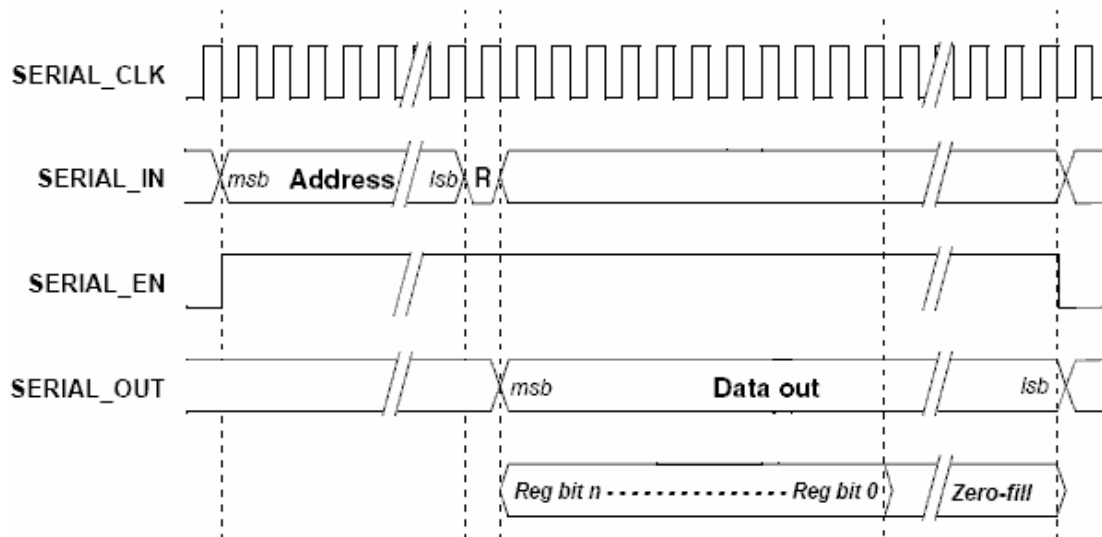

Figure 64. DAC serial read operation.

The DAC serial set up firmware uses four registers to interact with the DAC via the 4-wire serial control. The registers are DACSerialSetupReg, DACSerialAddr, DACDataReg and SerialOutReg. The first register is 3 bits long and influences the behaviour of the state machine. There are three options for this register to be configured which is shown in the table below.

Bit 2	Bit 1	Bit 0	No of Address and Data bits the state machine will clock out
0	X	W/R	10 Address bits 28 Data bits
1	0	W/R	7 Address bits 28 Data bits

1	1	W/R	7 Address bits 64 Data bits
---	---	-----	--------------------------------

Table 14. Configuration of the DACSerialSetupReg register.

The W/R in the last bit selects between a 'write' and a 'read' cycle.

The following figure shows the DAC state machine.

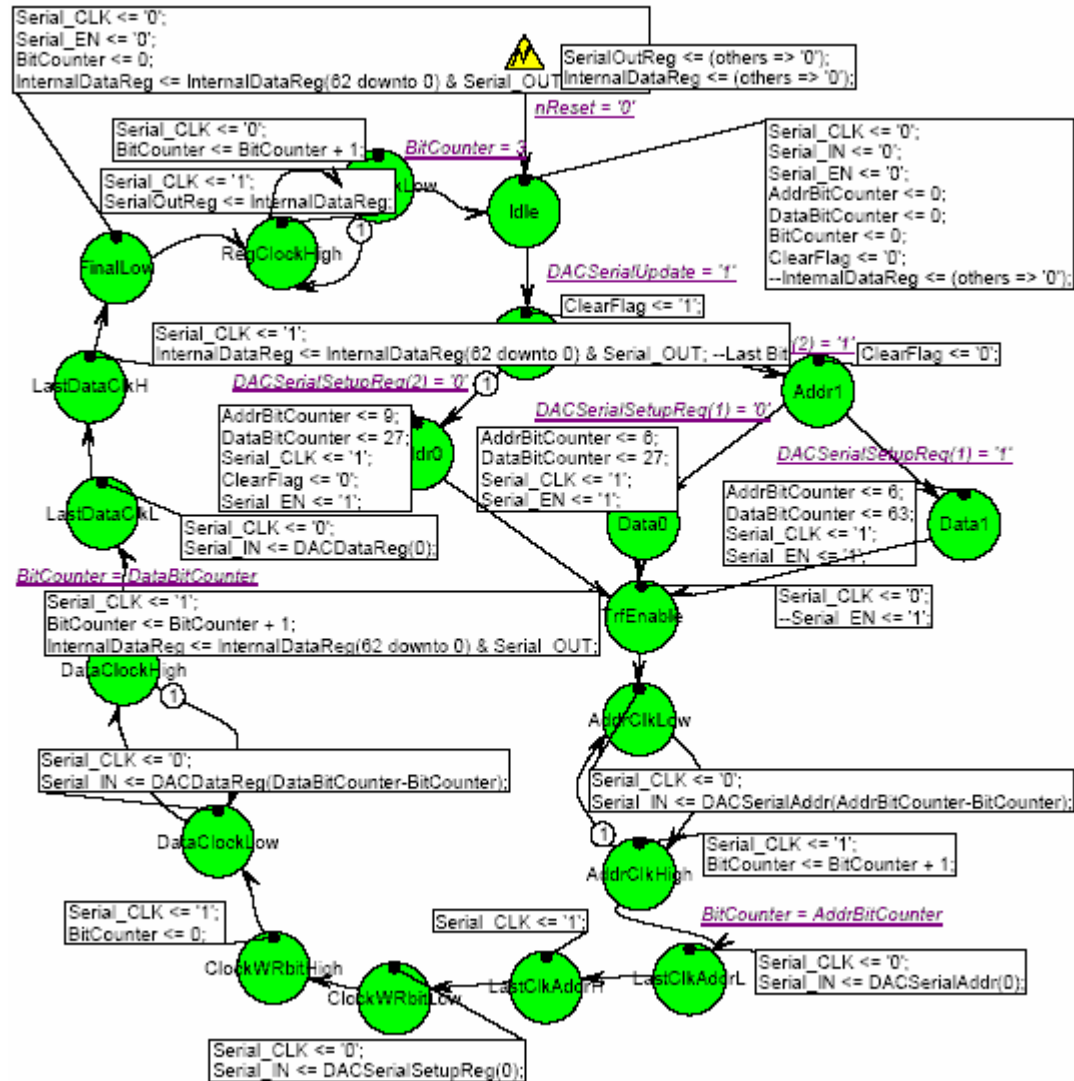

Figure 65. State machine of the DAC for the SMT381.

The state machine works in 5 stages:

- Initialisation
- Address clocked out
- Clock out write or read bit
- Data clocked out
- End sequence

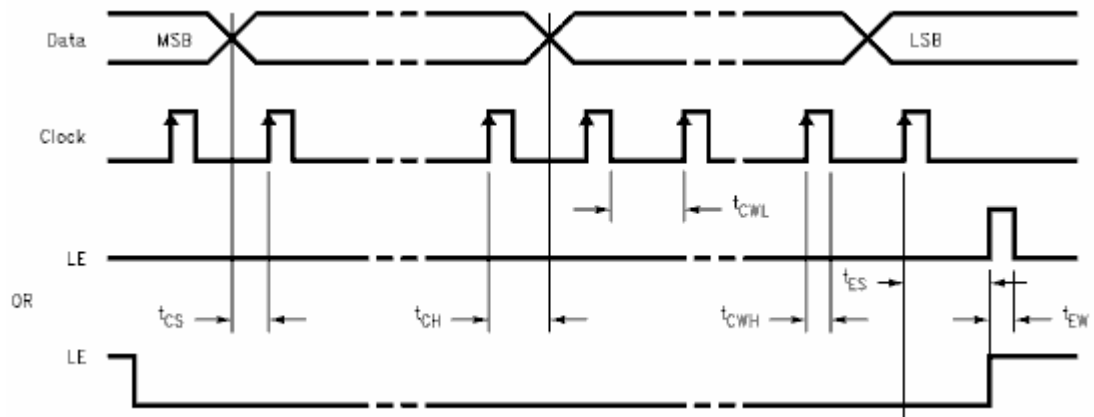

Figure 67. PLL Configuration Sequence.

The figure below explains the state diagram residing in the firmware design (SMT338-VP's Fpga). This design ultimately executes the procedures explained in the previous figures and paragraph.

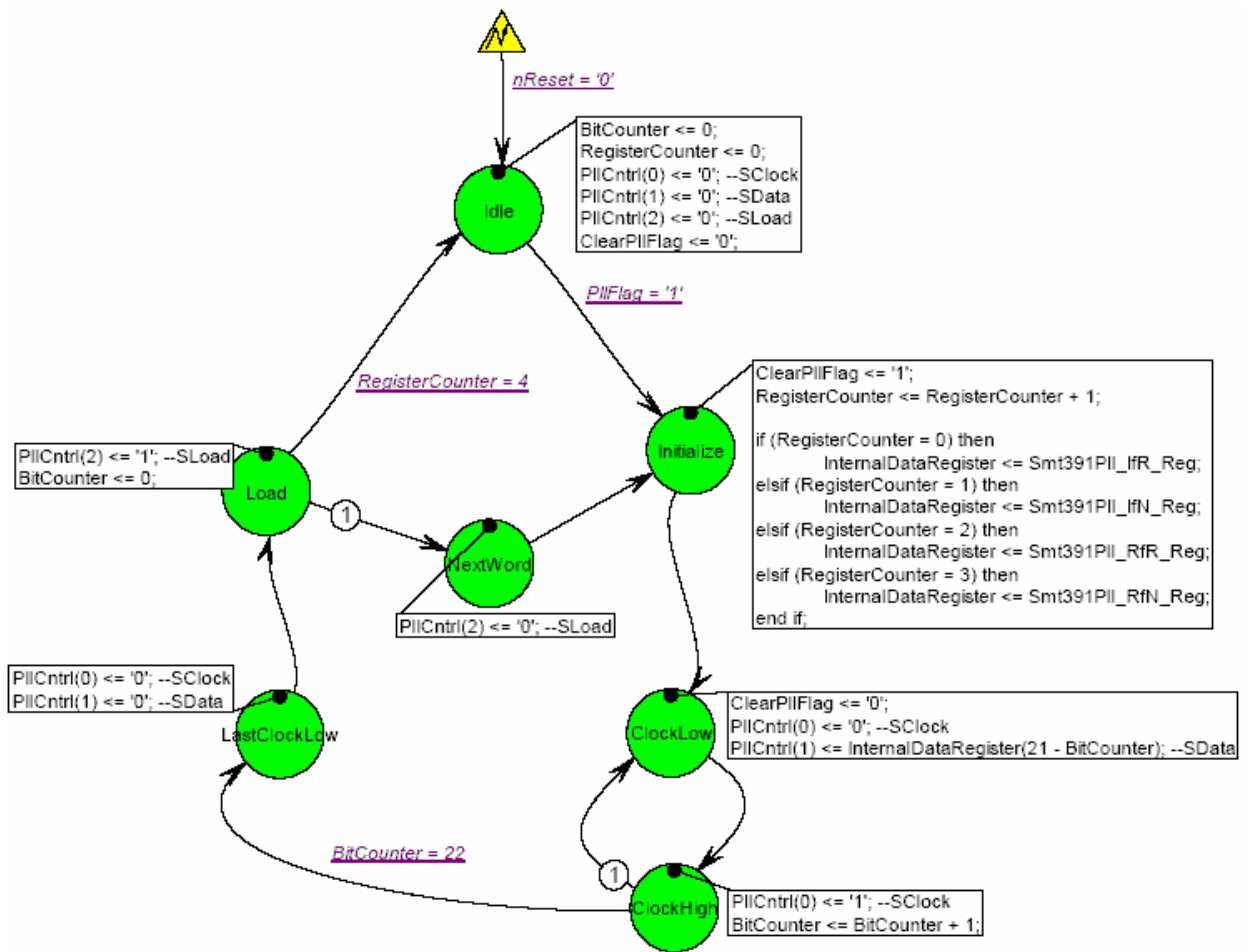

Figure 68. State Machine Driving the PLL Serial Interface.

11 Test Points

The following diagram shows all the Test points present on the board.

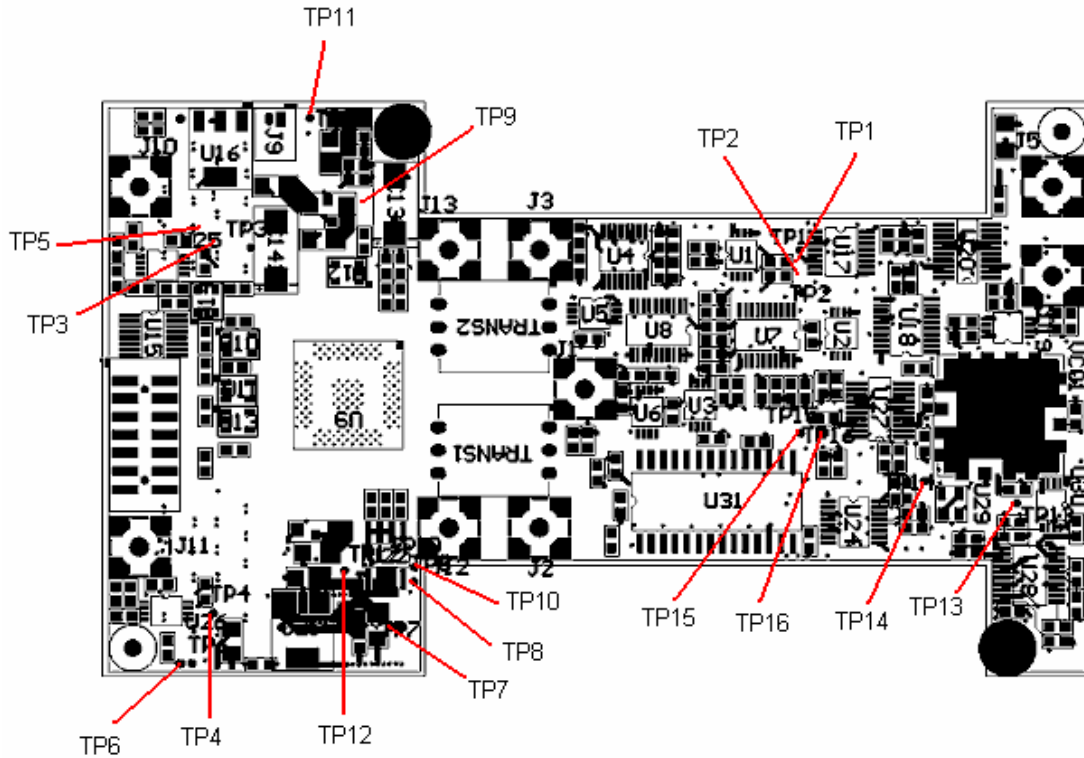

Figure 69. Test point locations on the SMT381.

- TP1 – External Clock positive
- TP2 – External Clock negative
- TP3 – Daughter Card Connector test point
- TP4 – Daughter Card Connector test point
- TP5 – Daughter Card Connector test point
- TP6 – Daughter Card Connector test point
- TP7 – 1V8 test point
- TP8 – 3V3_IN test point
- TP9 – ECL 5V test point
- TP10 – 3V3 test point
- TP11 – ECL -5V2 test point
- TP12 – Analog 3V3
- TP13 – VCO 12V
- TP14 – VCO 5V
- TP15 – VCO Clock positive
- TP16 – VCO Clock negative

12 APPENDIX A – Waveform Memory Setup

12.1 Introduction

This is a description of how to set up the SMT381-VP waveform memory. This demo system uses an SMT310Q carrier, an SMT365-8-2 DSP module in TIM 1 and an SMT381-VP (SMT338-VP base with SMT381 daughter card) in TIM 2. The zip file containing the code and FPGA bit-stream can be downloaded from here:

ftp://ftp2.sundance.com/Pub/Temp/SMT381_WaveformMemory.zip

10.2 System Setup

Connect ComPort 0 of the DSP module in TIM 1 to ComPort 3 of the SMT391-VP in TIM2.

10.2 Software Setup

Unzip the SMT381_WaveformMemory.zip file into the SMT6500 directory. This will create a Source and a Bitstreams directory. The Bitstreams directory contains the programming file for the FPGA of the SMT338-VP and the Source directory contains a file called SMT338VP_SMT3x1.app. This is the DSP application for programming the FPGA and for setting up the memory. Next run the .app file. The following screen will appear:

```
//*****//  
//   SMT391 Test Software - Version 1.0   //  
// Basic Setup: T1: SMT365; T2: SMT391; T3: SMT321 //  
//*****//
```

MAIN MENU:

- 1: Clear All FPGA Configurations
- 2: Configure the SMT338-VP FPGA in TIM 2
- 3: Configure the SMT321 FPGA in TIM 3
- 4: Send EndKey to SMT338-VP Micro in TIM 2
- 5: Enter the SMT338-VP + SMT391 Sub-Menu
- 6: Enter the SMT391 ATP Sub-Menu
- 7: Enter the SMT321 Sub-Menu
- 8: Exit

Select:

Figure 70. Test Program Main Menu.

Select option '2' and wait for the FPGA to configure. After configuration select option '5' to enter the SMT338-VP + SMT391 / SMT381 sub-menu. (Please note that some of the other functions will not work as they are relevant to different test setups, or work with different programming files).

```
//*****//  
// SMT391 Test Software - Version 1.0 //  
// Basic Setup: T1: SMT365; T2: SMT391; T3: SMT321 //  
//*****//
```

MM5: SMT338-VP + SMT391 SUB-MENU:

GENERAL OPTIONS:

- 1: Reset the FPGA
- 2: Read SMT338 Firmware Version
- 3: Write to the SMT338 Scratch Register
- 4: Read the SMT338 Scratch Register
- 5: Read SMT338 and Daughter Card Temperatures
- 6: Read the SMT338 Serial Number
- 7: Read the SMT391 Serial Number

ADC SPECIFIC OPTIONS:

- 8: Select the ADC clock source
- 9: Set Clock Synthesizer Frequency
- 10: Set VCO + PLL Frequency
- 11: Initialize the ADC and capture data
- 12: Read Data Ch I - CP
- 13: Read Data Ch Q - CP
- 14: Read Data SHB Rx A
- 15: Read Data SHB Rx B
- 16: Write SHB Buffer Data to File
- 17: Clear All Triggers
- 18: Read Trigger Register
- 19: Set RF PLL
- 20: Set IF PLL
- 21: Plain SHB A Read
- 22: Plain SHB B Read
- 23: MemA Write Start

DAC SPECIFIC OPTIONS:

- 24: Debug DAC

OTHER OPTIONS:

- 25: Return to the Main Menu

Select:

Figure 71. SMT338-VP Sub-Menu.

Select option '1' to reset the FPGA. Option '8' and then '0' to select the on-board VCO as the main clock source. Option '10' to set the VCO to 1000MHz and option '24' to enter the SMT381 debug menu. The following menu will appear:

```
//*****//  
// SMT381 Test Software - Version 1.0 //  
// Basic Setup: T1: SMT365; T2: SMT391; T3: SMT321 //  
//*****//
```

MM24: SMT381 DAC setup SUB-MENU:

DAC Core Registers:

- 1: DAC CORE CLOCK DELAYS Register Address:0x1B2
- 2: DAC CONFIG Register Address:0x1C0
- 3: SYSTEM CLOCK DELAYS Register Address:0x1C1
- 4: POWER DOWN Register Address:0x1C3
- 5: SYSTEM MISC Register Address:0x1C4

WaveForm Memory Module Registers:

- 6: WMM CONFIG Register Address:0x00
- 7: WMM EVEN CONFIG Register Address:0x10
- 8: WMM EVEN MUX CTRL Register Address:0x11
- 9: WMM EVEN RAM CTRL Register Address:0x12
- 10: WMM EVEN RAM DATA Register Address:0x13
- 11: WMM ODD CONFIG Register Address:0x20
- 12: WMM ODD MUX CTRL Register Address:0x21
- 13: WMM ODD RAM CTRL Register Address:0x22
- 14: WMM ODD RAM DATA Register Address:0x23

OTHER OPTIONS:

- 15: Reset DAC
- 16: Read a register
- 17: Return to the Main Menu

Select:

Figure 72. SMT381 Sub-Menu.

Select option '15' to reset the DAC. To enable the DAC to generate a block wave with data from the DAC select option '4' and then '0' for all the following questions until the main menu is displayed again.

To set the DAC up to generate an output using the internal waveform memory follow the following sequence (this is based on an example in the DAC datasheet (Page 43). Reset the DAC with option '15'. From there follow the following sequence:

Menu Option	Sequence to be entered (enter all from right to left, unless if indicated otherwise)
7	00
11	00
1	00
4	0011111100000
5	101
10	8192 (Enter as is) 16383 (Enter as is) 8192 (Enter as is) 1 (Enter as is)
9	100100
10	8192 (Enter as is) 16383 (Enter as is) 8192 (Enter as is) 1 (Enter as is)
9	101100
14	13984 (Enter as is) 13984 (Enter as is) 2400 (Enter as is) 2400 (Enter as is)
13	100100
14	13984 (Enter as is) 13984 (Enter as is) 2400 (Enter as is) 2400 (Enter as is)
13	101100
15	
1	00
4	0011111100000
5	101
7	01
11	01
7	01
11	01
6	100
8	00110011
12	00110011
9	000100
9	001100
13	000100
13	001100

Figure 73. Waveform Memory Setup Sequence.