

# SMT784

## User Manual

## Revision History

Date	Comments	Engineer	Version
27/01/09	Original Version	CHG	1.0

## Table of Contents

Revision History .....	2
Table of Contents .....	3
List of Figures .....	5
Physical Properties .....	6
Introduction .....	7
Related Documents .....	8
Acronyms, Abbreviations and Definitions .....	8
SMT784 Functional Description .....	9
System Overview .....	11
FPGA .....	11
SLB Connector .....	12
DDR2 .....	12
Front Panel Fibre Optic Modules .....	12
Front Panel RJ45 Connector (Ethernet) .....	12
Front Panel SATA Connectors .....	12
RSL .....	12
Flash .....	13
CPLD and FPGA Configuration .....	13
SHB .....	13
LEDs .....	13
Clock Distribution .....	14
ADS5500 ADCs. ....	15
Switch 1 Flash Settings .....	16
ADC Data Flow .....	18
Software Interface .....	19
Xilinx PCI Core .....	20
Sample Host Control and Data Capture .....	21
Getting Started .....	21
Host Control of SMT784 .....	23
Viewing the Samples .....	24
Uploading Firmware to Flash .....	24

---

SMT784 Board Layout.....	26
Top side of SMT700 Carrier.....	26
Bottom side of SMT700 Carrier .....	27
Top side of SMT384 Mezzanine .....	28
Bottom side of SMT384 Mezzanine.....	29
Power and Thermal .....	30
Power dissipation.....	30
Safety.....	31
EMC .....	31
Ordering Information.....	31

## List of Tables

Table 1 Clock Characteristics.....	15
Table 2 ADC Characteristics .....	16
Table 3 Common Configurations of Switch 1 .....	16
Table 4 Register 0x1C Data Control .....	23
Table 5 Mezzanine Connectors.....	28

## List of Figures

Figure 1: SMT700 Block Diagram .....	9
Figure 2 SMT384 Block Diagram .....	10
Figure 3 JTAG pin-out .....	11
Figure 4 Clock Distribution .....	14
Figure 5 ADC Data Flow.....	18
Figure 6 Software Interface to Firmware .....	19
Figure 7 Top-side of SMT700 Carrier.....	26
Figure 8 Bottom-side of SMT700 Carrier .....	27
Figure 9 Top-side of SMT384 Mezzanine .....	28
Figure 10 Bottom-side of SMT384 Mezzanine.....	29
Figure 11 3U Heat Dissipation.....	30

## Physical Properties

Dimensions		
Weight		
Supply Voltages	+12V	
	+5V	
	+3.3V	
	-5V	
	-12V	
Supply Current		
MTBF		

## Introduction

The SMT784 is a Virtex 5 based PXIe system utilizing Sundance's SMT700 carrier board and the SMT384 quad 125MSPS ADC mezzanine board. The SMT700 implements up to eight 2.5-Gigabit PCI Express lanes, allowing a maximum data transfer of 2 gigabytes per second. It also implements optionally a 32-bit, 33-MHz PCI interface. As a standard, the ADCs are all AC-coupled (RF Transformers), but can also be optionally DC-coupled (TI opamp [THS4509](#)). ADC configuration, sampling, and transferring modes are set via internal control registers stored inside the FPGA and accessible via a Comport interface.

The front panel interfaces make inter-system capabilities extremely extensive, while the ADC's and configurable clock distribution attached to the mezzanine module (SMT384) make processing raw data fast and simple to configure.

Together, the SMT784 is a powerful system for capturing and manipulating data at high speeds.

Main features of system:

- Xilinx Virtex 5 in an FF1136 package. Supports LX50T/LX85T/SX50T or LX110T/SX95T.
- FPGA configuration from flash (64MB) using a Xilinx Coolrunner CPLD.
- One 64-bit wide data bank of DDR2 memory. The bank uses 4, 16-bit wide devices. Running this memory at 220MHz provides a maximum access speed of over 3.5Gbyte/s.
- **Sundance LVDS Bus (SLB)** connector for interfacing the SMT700 carrier with the SMT384 mezzanine. (Future expanded functionality can be achieved as well by utilizing any one of Sundance's long line of other mezzanine modules)
- Front panel SATA connectors carrying Virtex5 serial interfaces.
- Front panel RJ45 for gigabit Ethernet.
- Front panel Fibre Optic modules carrying Virtex5 Serial interfaces.
- Sundance **Rocket Serial Link (RSL)** connector with 4 serial interfaces.
- Front panel USB interface to allow re-programming of the flash memory.
- Four 14-bit, 125MSPS analogue to digital converters.
- Flexible, on-board, low-jitter clock generation.
- One external clock, external triggers, and one reference clock via MMCX connector.
- All analogue inputs to be connected to 50-ohm sources/loads.
- Mezzanine module temperature sensors.

## Related Documents

Sundance RSL specification: [RSL](#)

Xilinx Virtex5 datasheets: [Xilinx Virtex5](#)

Texas Instruments ADS550 ADC datasheet: [ADS5500](#)

Analog Devices AD9510 datasheet: [AD9510](#)

Sundance High-speed Bus (SHB) specifications: [SHB](#)

Sundance LVDS Bus (SLB) specifications: [SLB](#)

TIM specifications: [TIM](#)

MMCX specifications: [Surface Mount MMCX](#)

## Acronyms, Abbreviations and Definitions

### [Sundance commonly used acronyms.](#)

MGT, GTP, RSL are all used (interchangeably) and refer to the FPGA's high speed serial links.



## SMT784 Functional Description

The major elements of the SMT784 can be broken down into the two main modules it is comprised of: the SMT700 and SMT384. The SMT700 PXIe carrier board block diagram can be viewed below.

### SMT700 Block Diagram

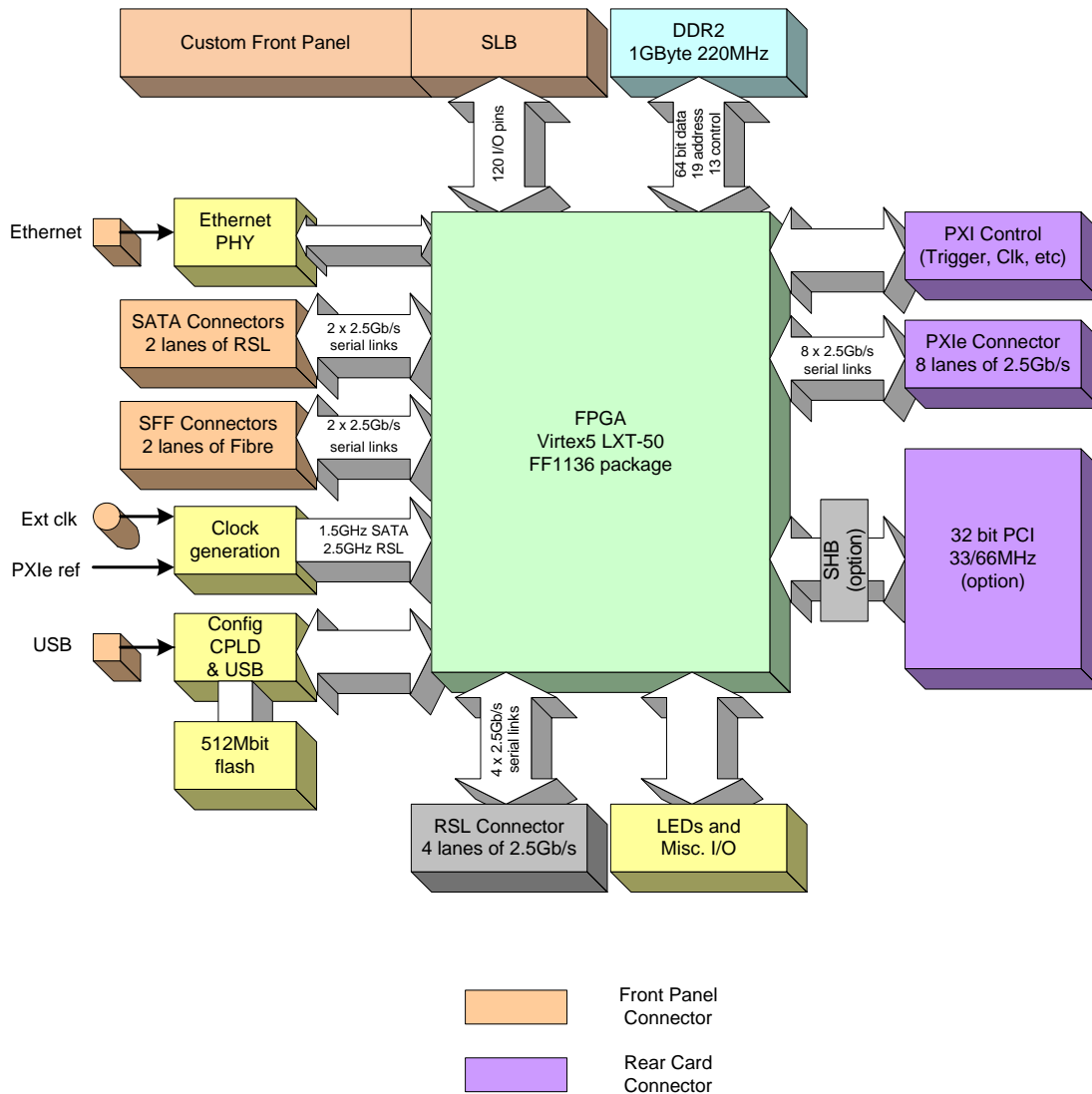

Figure 1: SMT700 Block Diagram

The SMT384 block diagram can be found below.

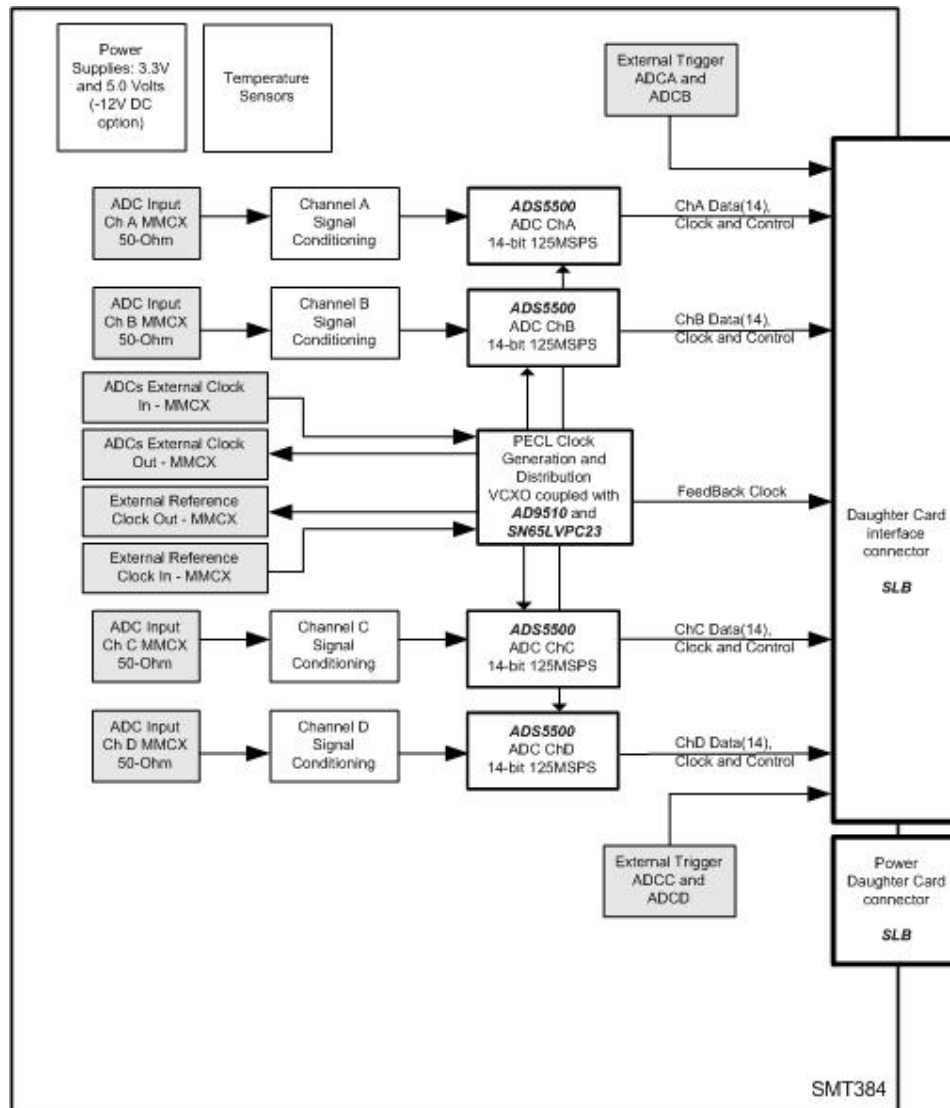

Figure 2 SMT384 Block Diagram

## System Overview

### FPGA

The SMT784 uses a Xilinx Virtex 5 LXT or SXT to implement in firmware the interfaces the board provides.

Configuration of the FPGA is from one of two sources: on-board flash memory or a Xilinx JTAG header.

A connector is specifically dedicated for FPGA and CPLD detection and programming. Both the CPLD and the FPGA are part of the JTAG chain. A 14-position (2x7) connector (2mm) is available and shows TDI, TDO, TCK and TMS lines, as well as a ground and a reference voltage, as shown below:

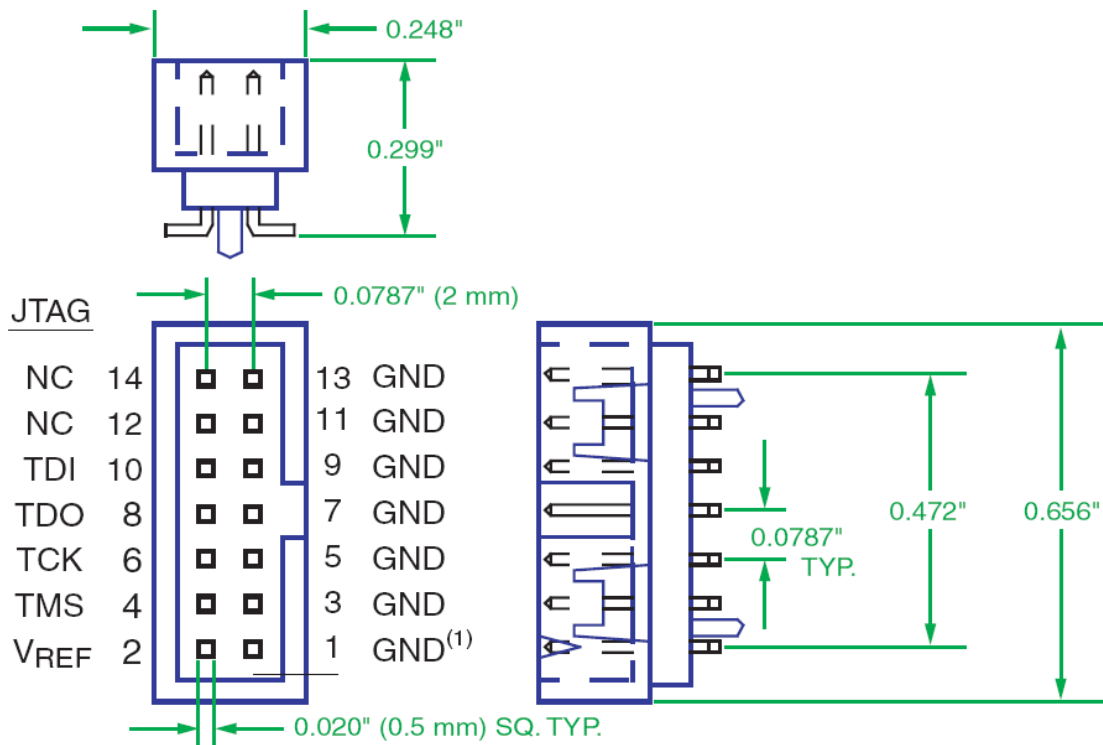

Figure 3 JTAG pin-out

This connector has been chosen because it can connect easily to a Xilinx Parallel IV cable using the ribbon cable provided by Xilinx.

The connector is a Molex part: Molex 87831-1428.

### ***SLB Connector***

The SLB connector is the interface used to connect the SMT700 carrier board to the SMT384 mezzanine module. For a map-out of SLB pin connections specific to this system, please refer to the [SMT384 user guide](#).

This connector is mounted on the reverse side of the board. The SMT784 occupies two slots in a rack with the carrier portion of the system residing on the central card guides (i.e. there will be a whole slot width for the FPGA, memory, etc. - and another slot with the SMT384 mezzanine. This approach greatly improves thermal design issues, whilst still remaining within the relevant backplane specifications.

### ***DDR2***

Four devices are used to implement this memory.

A 220MHz 64-bit data bus is used to transfer data at over 3.5Gbyte/s. (Xilinx provides performances of a DDR2 interface as being: 200MHz for a -1 part, 267MHz for a -2 part and 333MHz for a -3 part.) Future releases of the firmware will allow for Host application access of the memory provided.

### ***Front Panel Fibre Optic Modules***

Two FPGA serial interfaces are presented here using Stratos Lightwave 568-LxK-LT12x modules.

These interfaces support 2.5Gb/s operation.

### ***Front Panel RJ45 Connector (Ethernet)***

A single RJ45 connector provides a 10/100/1000 Ethernet interface. The RJ45 connects directly to a Marvell 88E1116 PHY, which is interfaced to the FPGA.

### ***Front Panel SATA Connectors***

Two SATA-style connectors are provided on the front panel. Each connector carries a single FPGA serial interface. As standard, these interfaces do NOT provide SATA connectivity.

### ***RSL***

The LXT/SXT series devices from Xilinx provide up to 16 high-speed (>3Gbps) serial links.

The SMT784 connects 8 lanes to the PXIe connector, 4 lanes to an RSL connector, two lanes to Fibre Modules, and two lanes to front panel SATA connectors.

For FPGAs with only 12 GTPs (high speed serial ports), no lanes are available on the RSL connector.

Future releases of the firmware will allow for Host application access of the RSL link.

### ***Flash***

This 64Mbyte memory contains the configuration bit-stream for the FPGA.

The flash contents may be programmed via the PXIe/PCI interface or via USB by using the SMT6002.

### ***CPLD and FPGA Configuration***

This Xilinx CPLD is capable of configuring the FPGA using data provided from the flash memory. The CPLD itself should not need to be re-programmed, but if needed it can only be accessed by JTAG using Xilinx iMPACT.

The CPLD also interfaces to a Cypress USB device. This interface allows an easy option for upgrading the FPGA configuration stored in flash using the SMT6002.

The USB mechanism to re-program the flash is always present and does not rely on the FPGA being configured. This can be advantageous if the FPGA configuration has been updated with a non-working PCI interface.

### ***SHB***

Two Sundance SHB connectors are fitted as standard. Each connector has the ability to carry a 32-bit data bus with a data rate of 133MHz. A dual 16-bit interface option is also supported.

One SHB is connected directly to the FPGA. To save on pin-count, the second SHB connector shares the PCI interface signals with the FPGA. For this reason, this SHB interface and the PCI cannot be operated simultaneously unless a PCI express core is implemented in firmware.

### ***LEDs***

Two front-panel LED's are available and connected directly to the FPGA. A heartbeat signal present indicates the FPGA has been configured correctly.

## Clock Distribution

There is one integrated clock generator on the mezzanine module (AD9510 – Analog Devices). The user can either use this clock (on-board) or provide the module with an external clock (input via MMCX connector).

ADCs can all receive the same clock or the integer multiple of it (x2, x3.....x32), the maximum being 125MHz for each ADC. This clock can be coming from the on-board VCXO or from an external source.

An extra connector outputs the reference clock for multiple-module systems.

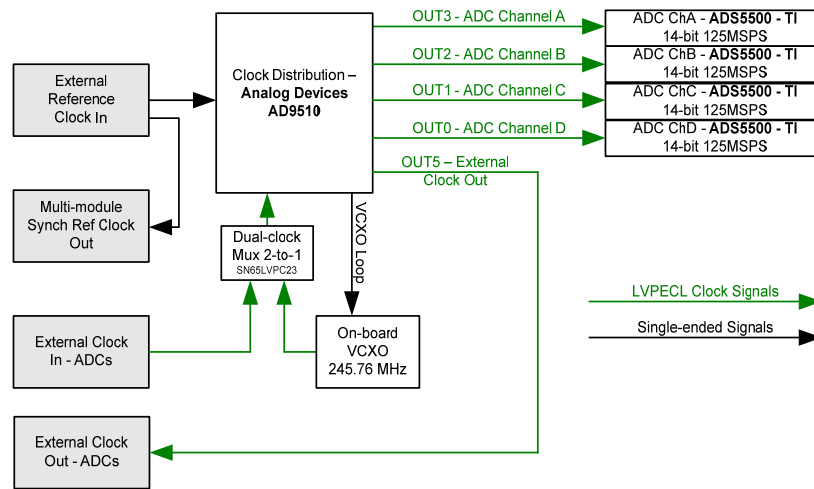

Figure 4 Clock Distribution

The main characteristics of the mezzanine clocks are as follows:

External Reference Input	
Input Voltage Level	0.5 – 3.3 Volts peak-to-peak (AC-coupled)
Input Impedance	50-Ohm (Termination implemented at the connector)
Frequency Range	0 – 100 MHz.
External Reference Output	
Output Voltage Level	1.6 Volts peak-to-peak (AC-coupled)
Output Impedance	50-Ohm (Termination implemented at the connector)
External Sampling Clock Input	
Input Voltage Level	0.5 – 3.3 Volts peak-to-peak (AC-coupled)
Format	Single-ended or differential on option (3.3V LVPECL).
Frequency range	10-125 MHz

External Sampling Clock Output	
Output Voltage Level	0-2.4 Volts fixed amplitude.
Output Format	LVTTTL
External Trigger Inputs	
Input Voltage Level	1.5-3.3 Volts peak-to-peak.
Format	DC-coupled and Single-ended (Termination implemented at the connector). Differential on option (3.3 V PECL).
Impedance	50-Ohm.
Frequency range	62.5 MHz maximum
Delay	
Ext. Ref. In to Ext Ref. Out	
Ext. Clk In to Ext Clk Out	11ns between J29 and J4

Table 1 Clock Characteristics

**ADS5500 ADCs.**

The main characteristics of the mezzanine ADC's are as follows:

Analogue Inputs	
Input voltage range	<p><b>AC coupled option.</b> 2.4 V<sub>pp</sub> (11.5 dbm – 50Ω) Full scale - AC coupled via RF transformer.</p> <p><b>DC-coupled option.</b> 1.15 V<sub>pp</sub> (Gain amplifier 6dB) centred at 0. DC-coupled via amplifier. Gain can be adjusted to required input amplitude centred at 0. Min. gain 6dBs, which should allow an input swing +/- 0.575V as full scale.</p>
Impedance	ADC single-ended inputs are to be connected to a 50Ω source. Source impedance matching implemented between RF transformers and ADC.
Bandwidth	ADC bandwidth: 750 MHz.
External Reference Input	
Input Voltage Level	0.5 – 3.3 Volts peak-to-peak (AC-coupled)
Input Impedance	50-Ohm (Termination implemented at the connector)
Frequency Range	0 – 100 MHz.
External Reference Output	
Output Voltage Level	1.6 Volts peak-to-peak (AC-coupled)
Output Impedance	50-Ohm (Termination implemented at the connector)
External Sampling Clock Input	
Input Voltage Level	0.5 – 3.3 Volts peak-to-peak (AC-coupled)

<b>Input Format</b>	Single-ended or differential on option (3.3V LVPECL).
<b>Frequency range</b>	10-125 MHz
<b>External Trigger Inputs</b>	
<b>Input Voltage Level</b>	1.5-3.3 Volts peak-to-peak.
<b>Format</b>	DC-coupled and single-ended (terminated at connector). Differential an option (3.3 V PECL).
<b>Impedance</b>	50-Ohm.
<b>Frequency range</b>	62.5 MHz maximum
<b>ADCs Output</b>	
<b>Output Data Width</b>	14-Bits
<b>Data Format</b>	2's Complement or offset binary (Changeable via control register)
<b>SFDR</b>	82dBs maximum (manufacturer)
<b>SNR</b>	70dBs maximum (manufacturer)
<b>Min Sampling Clock</b>	10 MHz (ADC DLL off)
<b>Max Sampling Frequency</b>	125 MHz (ADC DLL on)

Table 2 ADC Characteristics

**Switch 1 Flash Settings**

The following table represents the various switch settings for switch 1:

<b>POS 4</b>	N/A	N/A	N/A
<b>POS 3</b>	ON	OFF	ON
<b>POS 2</b>	OFF	OFF	ON
<b>POS 1</b>	N/A	N/A	N/A
<b>Flash condition</b>	SMT784 firmware Flash boot from user address (0x800000) Read/write access to flash	SMT784 firmware Flash boot from user address (0x800000) Read only access to flash	SMT700 firmware (Default boot at address 0x0) Read/write access to flash

Table 3 Common Configurations of Switch 1



Switch 1 on the front side of the SMT784 controls flash read and write access for the carrier board. SW1 positions 4 and 1 on V1 boards do not affect the operation of the carrier. SW1 position 3 ON allows read and write access to the flash from either PCI or USB, while the OFF position allows read only access. Position 2 ON boots from the backup SMT700 firmware, while off selects the SMT784 firmware.

The SMT700 default firmware is provided as a backup bit-stream in the event that user-modified firmware at address 0x800000 in flash does not work as expected. **Sundance therefore suggests that when writing custom firmware to flash, do not write to address 0x0 - only write to address 0x800000.**

## ADC Data Flow

The flow of ADC data in the SMT784:

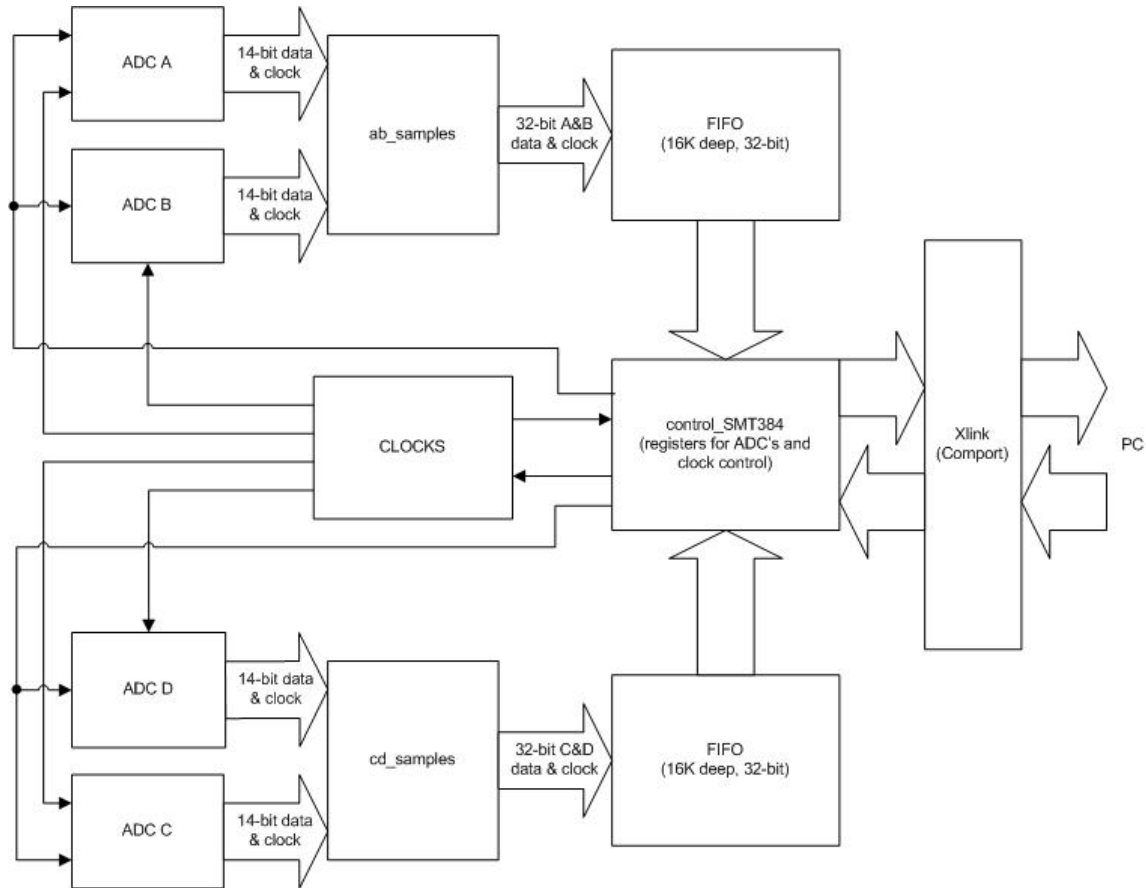

**Figure 5 ADC Data Flow**

The Control Registers contained in the FPGA (control\_SMT384) control the complete functionality of the SMT384. Registers are written to/from the PC via the X-Link interface (Comport). Contents of the registers or samples from the ADC's can be read back from the FPGA by choosing which output is desired. By changing the default firmware, samples from the ADC's can optionally be routed to the RSL links, SHB, SATA, etc.

Details of the registers functions, word format and a memory-map of the FPGA can be found in the [SMT384 User Guide](#).

Serial control signals are routed from the registers to the ADC's and to the clock distribution system for desired configuration. Samples and the clock output from the ADC's are then combined onto two different 32-bit buses, one containing samples from channels A and B, the other bus containing samples from channels C and D. In order to prevent loss of data, an asynchronous 16K buffer is implemented to feed the

samples to the control\_SMT384 block. When control registers are programmed to be returned to the PC, the ADC FIFO's are held in reset. Upon selection of the desired channel output, the buffer resumes operation.

## Software Interface

The following diagram shows functionally how the SMT784 works. **The hashed portions will be available in future releases of the firmware.** The Host accesses a number of communication resources via the PCI bus. All communication resources are presented as X-Link software interfaces, and are memory mapped in the memory space of the Host processor.

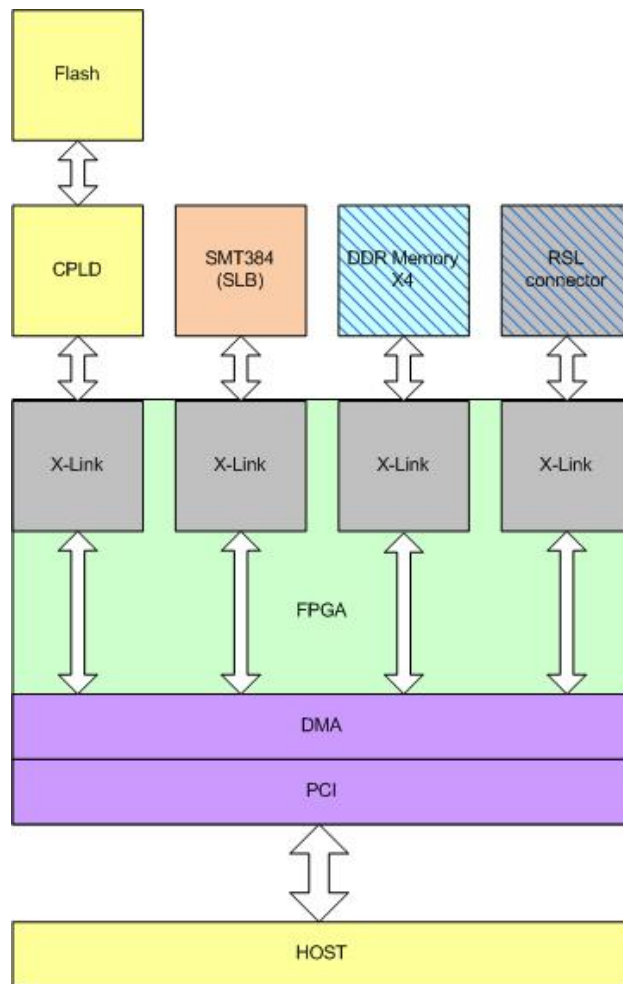

Figure 6 Software Interface to Firmware

The firmware inside the FPGA implements the communication interfaces required to allow the data transfer between the SMT784 and the Host PCI/PCIE.

The host transfers data with the SMT784 using the X-Link. There is one X-Link instantiated per communication resource (Flash, SMT384, DDR, RSL). All the X-Link interfaces are connected to the PCI core and can be accessed from the Host. The default firmware currently provides two communication resources: one Comport for interfacing the CPLD and Flash to the Host and one RSL currently used for ADC register control and data acquisition. Refer to the SMT6400 and SMT6500 for more information concerning the communication resources.

A Xilinx PCI IP core is used to allow data transfer between the Host machine and the X-Link.

### ***Xilinx PCI Core***

The PCI core supports target accesses and initiator accesses. Data transfers are implemented using initiator accesses to ensure maximum bandwidth. For this purpose a DMA engine is connected to the X-Link and the PCI core to transfer the data.

The PCI/PXIE interface used in this design was generated by using the Xilinx Core Generator (core version 4.8) included with ISE 10.1 Foundation software. The user is free to implement the included netlist into custom firmware, but if there is a need to re-generate the IP core, the full license must be purchased from Xilinx.

Licensing information and how to purchase this core can be found at the Xilinx website: [www.xilinx.com](http://www.xilinx.com)

### ***Driver***

The SMT784 is supported by the SMT6300 that provides the Windows driver for the board.

### ***Registers***

All the addressable resources are located in the BAR1.

The communication resources are presented to the host machine as X-Link interfaces. The addresses of the X-Link and the number of X-Link are available from the X-Link table of content found in the firmware.

Refer to the X-Link documentation for a description of the registers in the X-Link.

The other registers available in the firmware are the following:

#### **Reset register (BAR1 – 0x00000000)**

Writing '1' to the reset register will cause the SMT145 and the TIM plugged on it to be reset. The reset is de-asserted automatically after a few milliseconds.

### X-Link table of content (BAR1 – 0x00000400)

Refer to the X-Link documentation for the details of the table of content. Version 1.1

## **Sample Host Control and Data Capture**

### ***Getting Started***

The sample program “SMT784.exe” can get the user started with the equipment by executing some of the simpler functions available from the SMT784 system.

Setup:

- Connect the 50-ohm output of a signal generator to the ADC channel inputs (J3, J6, J7 and J11) on the mezzanine module. (Sundance provides a convenient, 50-ohm terminated splitter for inputting a single source through the SMT594.)
- Turn on the computer. Verify heartbeat signal flashing on the front-panel LED's. This indicates the FPGA is configured correctly.
- Execute “SMT784.exe”. This will store a 16K sample capture from each of the ADC's to a text file in the same folder as the executable.

The program begins by sending control and configuration words to the four ADC's and clock registers inside the FPGA. (The behaviour of these registers is thoroughly described in the user manual for the SMT384)

The Test Register on the FPGA is then written to verify proper read/write action over the X-Link Comport. Data is then captured from the ADC's and stored in text files relating to the ADC channel. (A\_capture.txt, B\_capture.txt, etc.)

If the program is successful you should see the following screen:

```
*****
*      System: SMT784      *
*****

ADC and Clock registers...

Register 0x02: 0
Register 0x05: 0
Register 0x08: 0
Register 0x0B: 0
Register 0x30: 10
Register 0x31: 0
Register 0x32: 0
Register 0x33: 0
Register 0x34: 47
Register 0x35: 10
Register 0x36: 0
Register 0x37: 1
Register 0x38: 0
Register 0x39: 1
Register 0x3A: 0
Register 0x3B: c0c
Register 0x3C: c0c
Register 0x3D: 101
Register 0x3E: 0
Register 0x3F: 200
Register 0x40: 0
Register 0x41: 0
Register 0x42: 0
Register 0x43: 0
Register 0x44: 0
Register 0x45: 0
Register 0x46: 0
Register 0x47: 0
Register 0x48: 3
Register 0x49: 100

Writing test counter to 0x1 Test Register.... 0 errors
UCKO status..... 0
Firmware..... 84

Acquiring data.... done. Check A_capture.txt
Acquiring data.... done. Check B_capture.txt
Acquiring data.... done. Check C_capture.txt
Acquiring data.... done. Check D_capture.txt

Speed Test..... done. Transfer duration: 2765 ms, Speed =60677 KB/s
```

The captured data samples can then be viewed and/or manipulated through the users preferred application. The provided MATLAB script file "ANALYSIS.m" provides an easy way to load and view the captured information through MATLAB.

### Host Control of SMT784

The provided sample program was created with Microsoft Visual C++ and the Sundance SMT6026 software development kit. In this example, the write function `writeword` uses the function `HostWrite` to write to the registers of the FPGA while `readword` uses `HostRead` to read the registers or data back through the X-Link:

```
void writeword(HOST_LINK hostlink, int value)
    {g_pSmt384->HostWrite(&value, sizeof(value), hostlink);}

void readword(HOST_LINK hostlink, int* ptr)
    {g_pSmt384->HostRead(ptr, sizeof(int), hostlink);}
```

Using `readword` can return control register information or samples from the ADC's. Which type of data to be read from the FPGA is selected by writing to register `0x1c` - the remaining control registers are exactly as described in the SMT384 User Manual.

By writing `0x0000` to register `0x1c`, `readword` will return register contents information, `0x0c00` will return raw data from channels A and B, and `0x800` will return raw data from channels C and D. It is important to remember the FIFO's are held at reset while register information is being read back from the Comport. This allows a quick empty of the FIFO for reading status and keeps data from being lost.

Word Sent	Function
<b>0x0000</b>	Resets all ADC sample FIFO's. Reading words back returns the contents in the registers address.
<b>0x0C00</b>	Channel A and B data is sent from the sample FIFO's. The 14-bit sample from each channel is returned in a concatenated, single 32-bit word as: "00" + "14-bit B sample" + "00" + "14-bit A sample"
<b>0x0800</b>	Channel C and D data is sent from the sample FIFO's. The 14-bit sample from each channel is returned in a concatenated, single 32-bit word as: "00" + "14-bit D sample" + "00" + "14-bit C sample"

**Table 4 Register 0x1C Data Control**

For example:

```
writeword(cp, 0x101C0000); // registers readable (clear FIFO's)
    for (k=0; k<255; k++) readword(cp, &value); // Empty FIFO
writeword(cp, 0x101C0C00); // Channels A&B binary out selected
```

In this instance, the first `writeword` places the ADC FIFO's in reset and configures the `0x1C` register to return register contents information to the Host when a `readword` is performed. The looped `readword` command empties samples remaining in the FIFO, and the final `writeword` configures the SMT784 to send samples from channels A and B in straight binary format to the Host.

### Viewing the Samples

By using the provided MATLAB script "ANALYSIS.m", the samples stored on the text files may be viewed. The following is a zoomed in view of a test run using channels C and D with a 2MHz analogue signal sampled at 33Mhz and a 4096-point FFT.

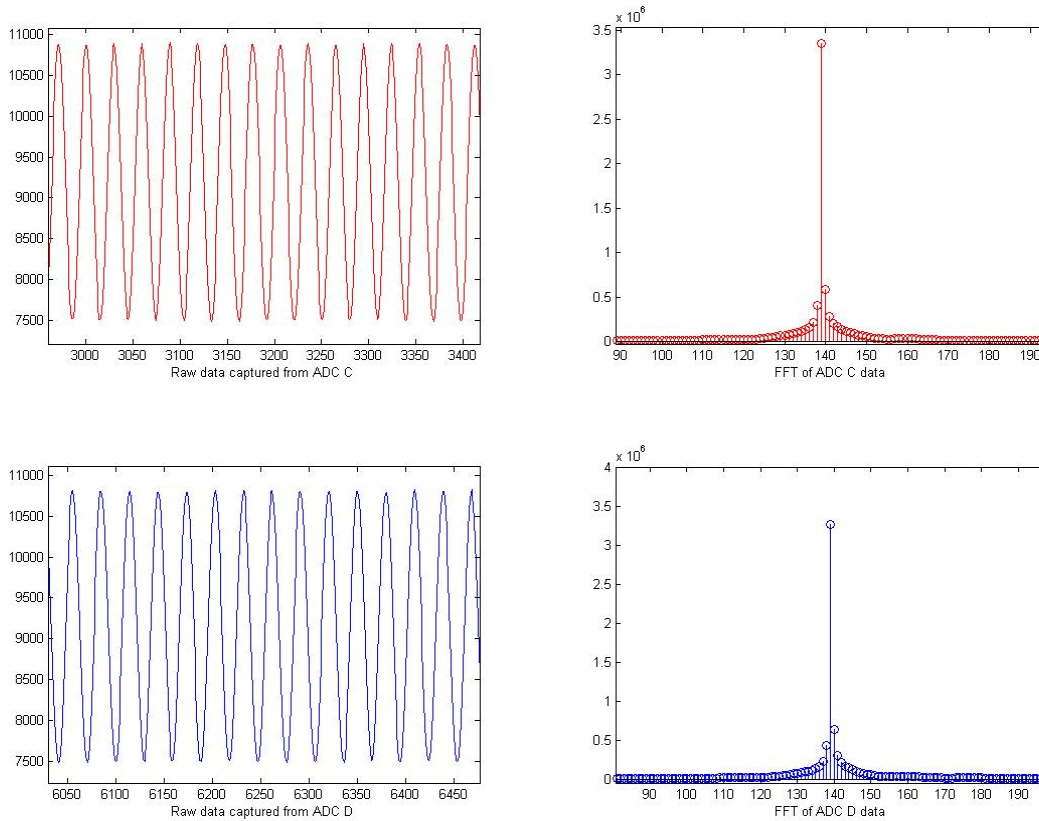

### Uploading Firmware to Flash

A good guide for how Sundance firmware is typically modelled can be found in the SMT6500 .chm help files.

The firmware provided may be updated from time to time or can be modified as desired to implement different functionality into the FPGA. For example, data flow



can be stored in DDR memory, output to the SATA connection, SHB, Ethernet, Fibre transceiver, etc.

The PCI controller for the SMT784 is in a VHDL wrapper within the Virtex5 FPGA. The SMT6002 Flash Utility can access the system's flash either through this PCI core or via a USB cable as in the SMT148-FX. Currently this means that a change to the firmware or a reset issued from Diamond Server will cause the FPGA to reconfigure from flash and lose the PCI interface. The flash can still be accessed at this point through the USB interface, but if the PCI is to be recognized by the Host again there must be either a re-boot of the PC or the equipment must be un-installed then re-installed as follows:

- Connect a USB cable to the SMT784 and start the SMT6002 Flash Utility for FPGA-only Modules. The system will appear in the utility as an SMT700 through the PCI interface and as an SMT148-FX through the USB interface. (The TIM type will appear as an SMT351T-xxxx depending upon type of FPGA on carrier)
- Select the interface of choice as noted in the above step (PCI or USB). Two bit-streams will be found in the flash, the first is the default firmware for the SMT700, while the second bit-stream at address 0x800000 is where the SMT784 configuration is stored.
- Select the **second** bit-stream, delete and re-assign the updated or custom firmware you have designed at user address 0x800000. Select Commit.
- Once the firmware has been loaded into flash, open a Diamond Server instance and reset the board to reconfigure the FPGA with the new bit-stream (check SW1 settings).
- To make the board visible again on PCI, right-click "My Computer", and select "Manage".
- Under "Device Manager", select "SMT700" under "Sundance". Right click, disable. (click okay)
- Right click "SMT700" again, select "enable."

This will cause the PCI address of the device to be discovered again as an SMT700 with the new firmware installed.

# SMT784 Board Layout

## Top side of SMT700 Carrier

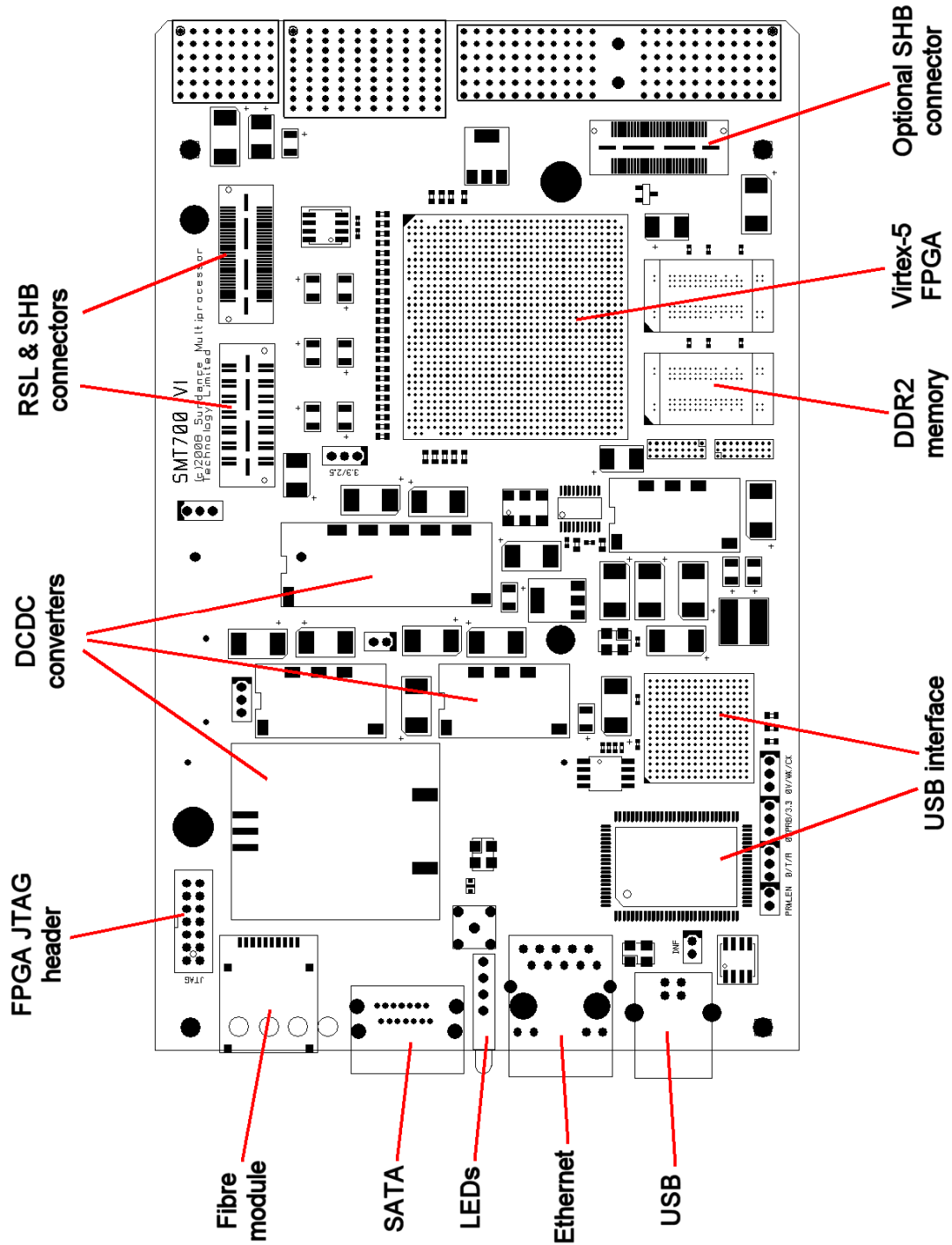

Figure 7 Top-side of SMT700 Carrier

### Bottom side of SMT700 Carrier

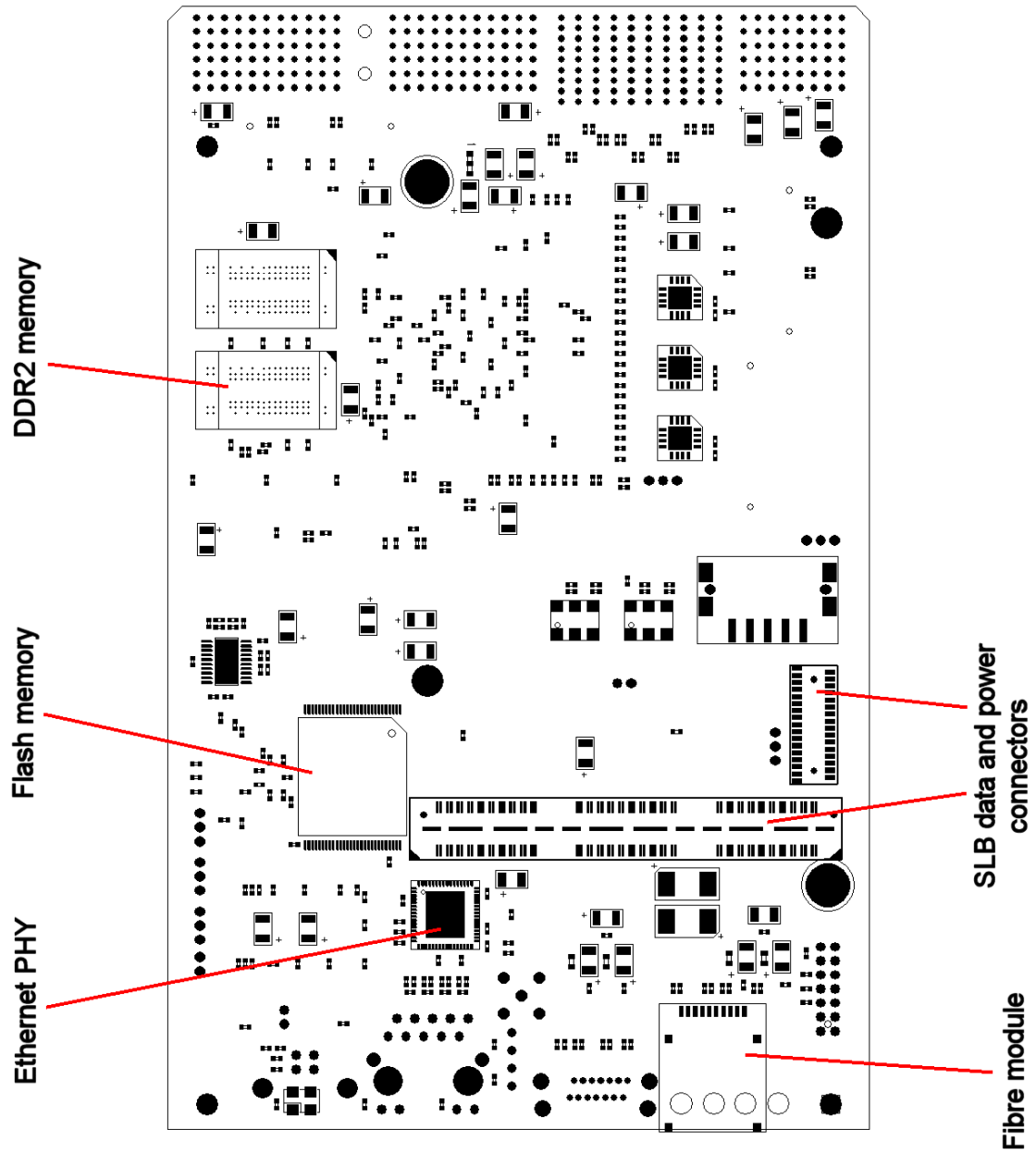

Figure 8 Bottom-side of SMT700 Carrier

### Top side of SMT384 Mezzanine

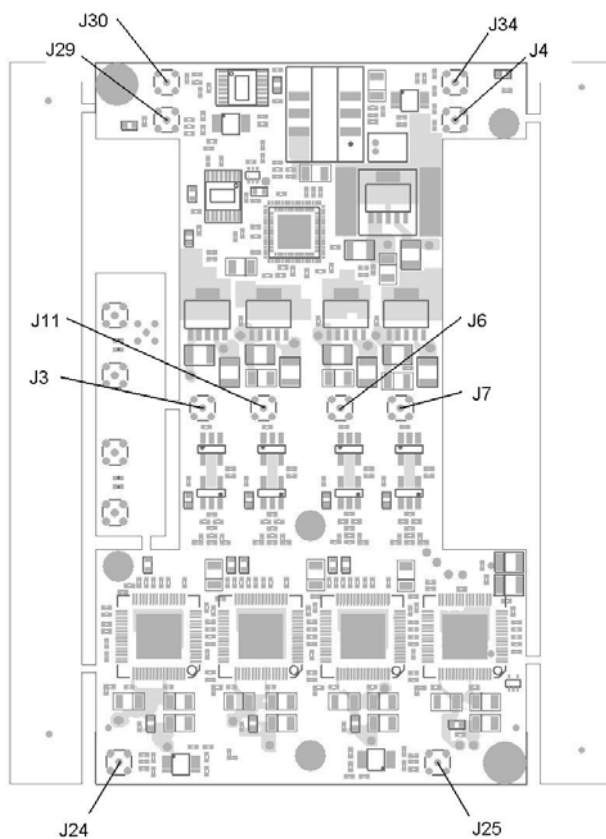
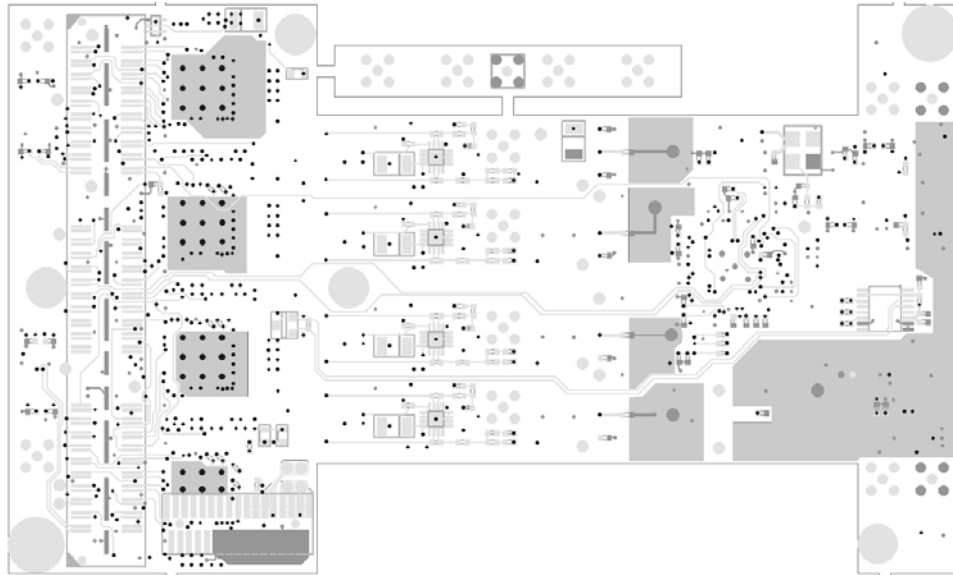

Figure 9 Top-side of SMT384 Mezzanine

Connector name (silkscreen and schematics)	Description	Location on the board
<b>J3</b>	ADCA Analog Input	Middle / Left
<b>J11</b>	ADCB Analog Input	Middle / Left
<b>J6</b>	ADCC Analog Input	Middle / Right
<b>J7</b>	ADCD Analog Input	Middle / Right
<b>J30</b>	External Reference Input	Top / Left
<b>J29</b>	External Clock Input	Top / Left
<b>J34</b>	External Reference Output	Top / Right
<b>J4</b>	External Clock Output	Top / Right
<b>J24</b>	External Trigger ADCA&B	Bottom / Left
<b>J25</b>	External Trigger ADCC&D	Bottom / Left

Table 5 Mezzanine Connectors

***Bottom side of SMT384 Mezzanine***



**Figure 10 Bottom-side of SMT384 Mezzanine**

## Power and Thermal

### ***Power dissipation***

The PXI Express chassis receiving the SMT784 system should provide enough forced air flow in order to dissipate the heat generated by the modules. The air flow must be going against gravity or upwards, as specified in the PXI Specification.

It is also specified that a 3U PXI Express module should not dissipate more than 30 Watts of heat.

The following picture shows the direction of the forced air flow across a 3U PXI Express module:

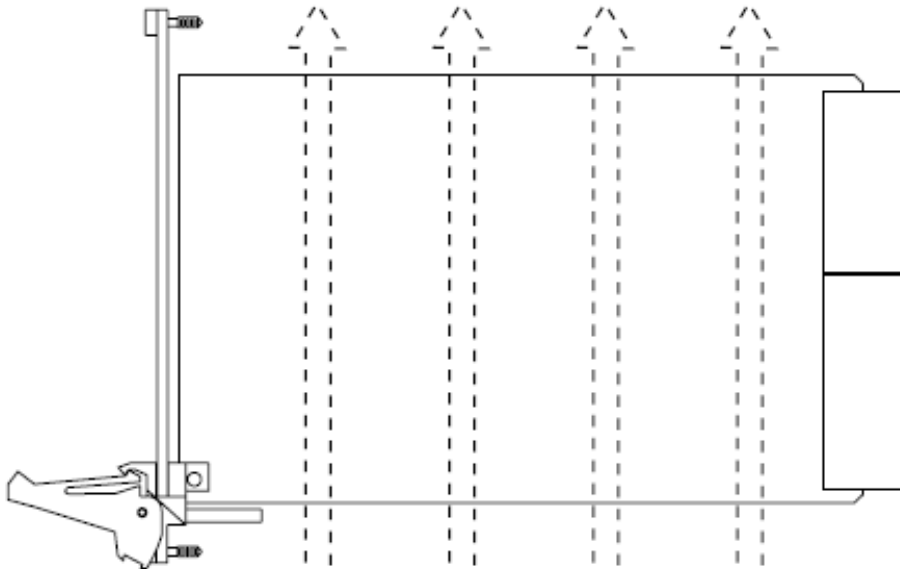

**Figure 11 3U Heat Dissipation**

The estimated maximum power consumption of the Virtex5 FPGA is 22W. This assumes a design running at 500MHz with all DSP slices used.

All of the devices on the SMT784 derive their power from the +12V PXI power rails.

It is strongly advised, as applications vary considerably, to use the Xilinx power estimator tools available from this link;

[Xilinx Power Design Solutions](#)

## **Safety**

This module presents no hazard to the user when in normal use.

## **EMC**

This module is designed to operate from within an enclosed host system, which is build to provide EMC shielding. Operation within the EU EMC guidelines is not guaranteed unless it is installed within an adequate host system.

This module is protected from damage by fast voltage transients originating from outside the host system which may be introduced through the output cables.

Short circuiting any output to ground does not cause the host PC system to lock up or reboot.

## **Ordering Information**

Several variations of this product are available. Various FPGA types, speed grades, clock speeds and signal coupling are available. Please contact Sundance for further information.