

Unit / Module Description:	Quad ADC SLB Module
Unit / Module Number:	SMT941
Document Issue Number:	2
Issue Date:	
Original Author:	PhSR

User Manual for SMT941

Sundance Multiprocessor Technology Ltd, Chiltern House,
Waterside, Chesham, Bucks. HP5 1PS.

This document is the property of Sundance and may not be copied
nor communicated to a third party without prior written
permission.

© Sundance Multiprocessor Technology Limited 2009



Revision History

Issue	Changes Made	Date	Initials
1	Original document 'pre-released'.	06/11/2009	PhSR
2	Updates to match v2 PCB	23/03/2010	PhSR

Table of Contents

Precautions	5
Introduction.....	6
1 Related Documents	7
1.1 Referenced Documents.....	7
1.2 Applicable Documents.....	7
2 Functional Description.....	8
2.1 Block Diagram.....	8
2.2 Module Description	8
2.2.1 A/D converters	9
2.2.2 Clock structure	10
2.3 FPGA Design.....	11
2.3.1 Control Register Settings.....	11
2.3.2 Register Descriptions	13
Control Register - 0x1.....	13
CLOCK Register 0 - 0x10.....	14
CLOCK Register 1 - 0x11.....	15
CLOCK Register 2 - 0x12.....	15
CLOCK Register 3 - 0x13.....	15
CLOCK Register 4 - 0x14.....	16
CLOCK Register 5 - 0x15.....	17
CLOCK Register 6 - 0x16.....	17
CLOCK Register 7 - 0x17.....	18
CLOCK Register 8 - 0x18.....	18
CLOCK Register 9 - 0x19.....	19
CLOCK Register A - 0x1A.....	19
CLOCK Register B - 0x1B.....	20
CLOCK Register C - 0x1C.....	20
CLOCK Register D - 0x1D.....	21
CLOCK Register E - 0x1E.....	21
CLOCK Register F - 0x1F.....	21
CLOCK Register 10 - 0x20.....	22
CLOCK Register 11 - 0x21.....	22
CLOCK Register 12 - 0x22.....	22
CLOCK Register 13 - 0x23.....	23
CLOCK Register 14 - 0x24.....	23
CLOCK Register 15 - 0x25.....	24
CLOCK Register 16 - 0x26.....	24
CLOCK Register 17 - 0x27.....	25
CLOCK Register 18 - 0x28.....	26
CLOCK Register 19 - 0x29.....	26
ADC Chab Register 0 - 0x30.....	27
ADC Chab Register 1 - 0x31.....	27

	ADC Chab Register 2 - 0x32.....	28
	ADC Chab Register 3 - 0x33.....	28
	ADC Chab Register 4 - 0x34.....	29
	ADC Chab Register 5 - 0x35.....	29
	ADC Chab Register 6 - 0x36.....	30
	ADC Chab Register 7 - 0x37.....	31
	ADC Chab Register 8 - 0x38.....	32
	ADC Chab Register 9 - 0x39.....	32
	ADC Chcd Register 0 - 0x40.....	33
	ADC Chcd Register 1 - 0x41.....	33
	ADC Chcd Register 2 - 0x42.....	34
	ADC Chcd Register 3 - 0x43.....	35
	ADC Chcd Register 4 - 0x44.....	35
	ADC Chcd Register 5 - 0x45.....	36
	ADC Chcd Register 6 - 0x46.....	37
	ADC Chcd Register 7 - 0x47.....	37
	ADC Chcd Register 8 - 0x48.....	38
	ADC Chcd Register 9 - 0x49.....	39
3	PCB Layout	40
3.1	Top View.....	40
3.2	Bottom View.....	40
4	Connectors	41
4.1	Description.....	41
4.2	Location on the board.....	42
5	Physical Properties.....	43
6	Safety	43
7	Ordering Information	43
8	EMC	43

Table of Figures

Figure 1 - SMT942 Block diagram.....	8
Figure 2 - Clock Structure - Block Diagram	10
Figure 3 - Clock Architecture Main Characteristics.	11
Figure 4 - Setup Packet Structure.	12
Figure 5 - Control Register Read Sequence.....	12
Figure 6 - Register Memory Map.	13
Figure 7 - Connectors	42

Precautions

In order to guarantee that Sundance's boards function correctly and to protect the module from damage, the following precautions should be taken:

- They are static sensitive products and should be handled accordingly. Always place the modules in a static protective bag during storage and transition.

Introduction

The *SMT941* is a single width expansion TIM that plugs onto an [SLB](#) base module, the [SMT351T](#) (Virtex-5 LXT, SXT or even FXT FPGA) as an example and incorporates 2 Texas Instrument dual-channel Analog-to-Digital Converters ([ADS62P49](#)). The *SMT941* implements a comprehensive clock circuitry based on a distribution chip ([CDCE72010](#)) from Texas Instrument that allows synchronisation among the converters and the use of an internal/external reference clock or internal/external sampling clock. It provides a complete conversion solution and stands as a platform that can be part of a transmit/receive communication platform. The *SMT941* has an on-board VCXO of frequency 245.76MHz.

ADCs have a resolution of 14 bits and are able to update outputs at up to 250MHz. All converters are 1.8/3.3-Volt. ADCs internal gain and offset can be adjusted as well as the data format. ADCs are AC-coupled on the board using a double-transformer structure. No DC-coupled version is currently available.

The [Xilinx FPGA](#) (Virtex-5 LXT or SXT series in the case of the *SMT351T*) on the base module is responsible for handling data coming from one of the following sources: Comports or Rocket Serial Link ([RSL](#)). These interfaces are compatible with a wide range of Sundance's modules.

The memory (DDR2 on *SMT351T*) on the base module can be used to store incoming samples.

Converter configuration, sampling and transferring modes are set via internal control registers stored inside the FPGA and accessible via Comport.

The *SMT941* module is well-suited for multi-carrier, wide bandwidth communication applications.

Note that the *SMT941* requires to be coupled with an *SLB* base module set to work with 2.5V FPGA IOs.

The main features of the *SMT941* are listed below:

- Two Dual 14-bit 250MSPS ADC ([ADS62P49](#)),
- On-board low-jitter clock distribution chip ([CDCE72010](#)),
- On-board 245.76MHz VCXO,
- On-board 10MHz reference crystal,
- One external clock, and one reference clock inputs via [MMCX](#) connector,
- One external clock output via [MMCX](#) connector,
- One external trigger input via [MMCX](#) connector (can also be used as an output),
- One [SLB](#) connector to link *SMT941* and *SMT351T* as an example,
- All Analogue inputs to be connected to 50-Ohm sources.
- All Analogue outputs to be connected to 50-Ohm loads.
- A fan.

1 Related Documents

1.1 Referenced Documents

ADC datasheet: [Texas Instrument ADS62P49](#).

Clock datasheet: [Texas Instrument CDCE72010](#).

1.2 Applicable Documents

2 Functional Description

2.1 Block Diagram

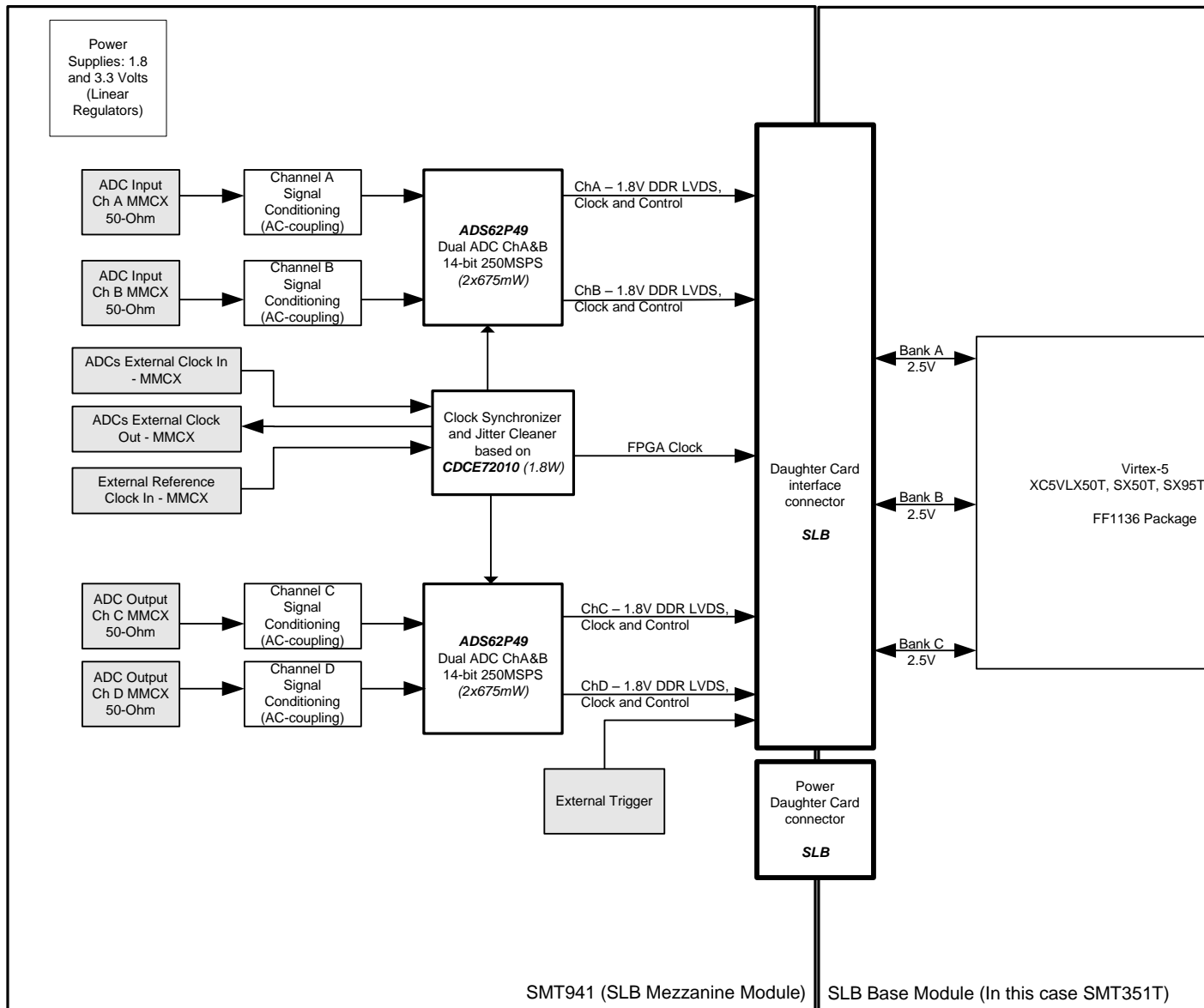

Figure 1 - SMT942 Block diagram.

2.2 Module Description

The SMT941 has got 2 dual channel Analog-to-Digital converters ([ADS62P49](#) - Texas Instrument) that have been designed for multi-carrier, wide bandwidth communication applications. All 4 analog inputs are available on MMCX connectors. They are 50-Ohm AC-coupled inputs (RF transformers - ration 1). DDR LVDS lines are used to carry samples through the SLB connector to the FPGA (SLB base module - FPGA IOs must be 2.5-Volt).

A clock distribution chip ensures that all converters sample synchronously to a single clock source. The clock source can be external or internal (on-board 245.76-

MHz VCXO). The distribution chip also allows synchronising the on-board VCXO to a reference signal that can be external or internal (on-board 10-MHz crystal). External reference, external sampling clock input and output are accessible on MMCX connectors. An external trigger input is also available on the board (it is implemented as an input in the default firmware provided but can also be implemented as an output).

All control, data and clock lines are mapped onto an SLB connector so the card can be fully controlled by an SLB FPGA base module (SMT351T for example, with 2.5-Volt FPGA IOs).

Some green LEDs are available on the board. A group of four LEDs is driven directly from the SLB base FPGA module and can be used to return status bits. Other individual LEDs should be lit and show that local power supplies are on.

2.2.1 A/D converters

The main characteristics of the SMT941 are gathered into the following table.

Analogue Inputs	
Input voltage range	<p>0dB <u>gain setting</u> : 2.3Vpp - Full scale - AC coupled</p> <p>6dB <u>gain setting</u> : 1.15Vpp – Full Scale – AC-coupled</p> <p>Programmable input gain via register (0...6dBs) by steps of 0.5dB (coarse gain) and steps of 0.134dB (fine gain).</p>
Impedance	Single-ended inputs – to be connected to a 50Ω (AC) source.
Bandwidth	Tbd – depends on ADC internal input gain.
ADC characteristics	
Output Data Width per channel	14 Bits
Data Format	2's Compliment or offset binary (Changeable via control register)
SFDR	75 (0-db gain) / 82dBs (6-db gain) maximum (manufacturer)
SNR	69 (0-db gain) / 66dBs (6-db gain) maximum (manufacturer)
ENOB	11.3 bits maximum (manufacturer)
Maximum Sampling rate	250 MSPS (1...100MSPS low speed mode) (100...250MSPS high speed mode)
Minimum Sampling rate	1 MSPS

ADC Analog inputs on the board are single-ended. A double RF transformer structure is used to provide single-ended to differential conversion. Both transformers are identical and have a ratio of 1. In order to match the 50-Ohm at the connector, the output of the second transformer has two 25-Ohm resistors terminated to the ADC common mode voltage.

2.2.2 Clock structure

The following diagram shows the clock structure of the SMT941:

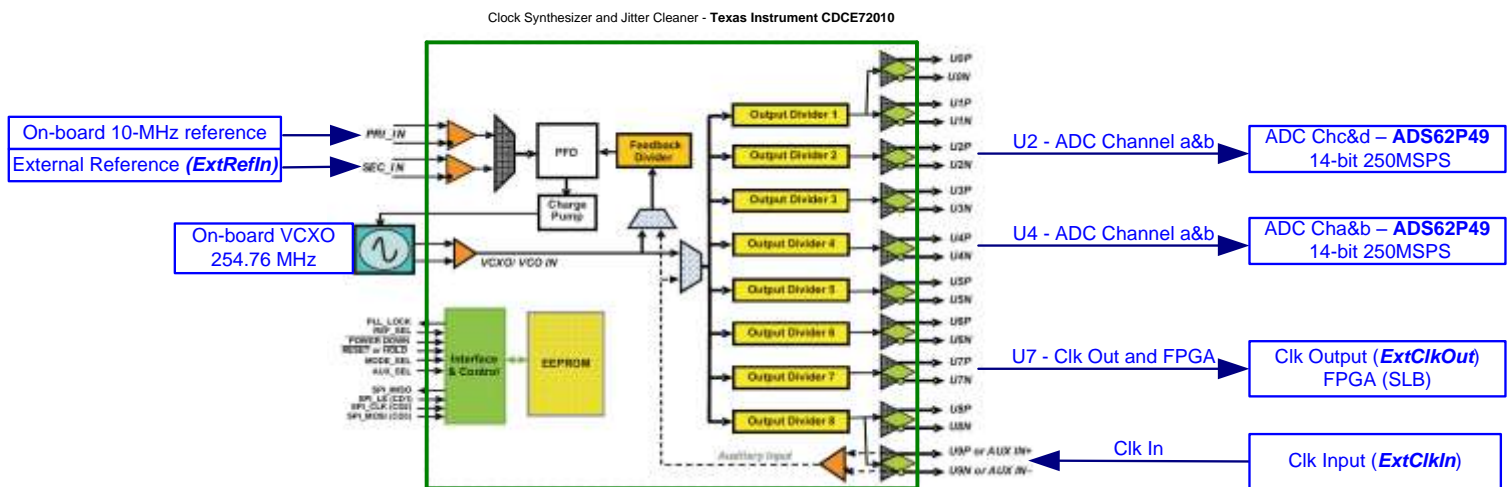

Figure 2 - Clock Structure - Block Diagram

The clock distribution chip used on the SMT941 offers 2 reference inputs, a VCXO differential input and a charge pump to drive the VCXO, as well as a second differential clock input. ADCs and external clock are mapped to separate internal output dividers in order to give more flexibility.

The CDCE72010 chip is designed to provide clean, phase related clocks to the converters. The reference clock (on-board or external) is used to lock the on-board VCXO using the clock chip PLL/charge pump. It is also possible to feed an external sampling clock to the chip that can then be distributed the analog converters.

Note that when the board is mounted onto a PXI SLB carrier such as the SMT700 (with 2.5-Volt FPGA IOs), it is possible to feed the 10-MHz reference clock (PXI bus) to the SMT941 order to lock the VCXO, then creating a local source synchronised to the rest of the system.

Also to be noted is that a VCXO of a different frequency can be fitted to replace the standard 245.76-MHz one. It is to be discussed prior to ordering as it is an operation carried out in the factory.

The table below gathers the characteristics of all clock inputs/outputs:

External Reference Input

Input Voltage Level	1 – 3.3 Volts peak-to-peak (AC-coupled)
Frequency Range	0 – 100 MHz.
External Reference Output	
Output Voltage Level	1.6 Volts peak-to-peak (AC-coupled)
Output Impedance	50-Ohm (Termination implemented at the connector)
External Sampling Clock Input	
Input Voltage Level	1.5 – 3.3 Volts peak-to-peak (AC-coupled)
Input Format	Single-ended.
Frequency range	10-500 MHz
External Sampling Clock Output	
Output Voltage Level	0-2.4 Volts fixed amplitude
Output Format	LVTTTL
External Trigger Inputs	
Input Voltage Level	1.5-3.3 Volts peak-to-peak.
Format	DC-coupled and Single-ended (Termination implemented at the connector). Differential on option (3.3 V PECL).
Impedance	50-Ohm.
Frequency range	62.5 MHz maximum
Delay	
External Ref. Input to Ext Ref. Out	
External Clk Input to Ext Clk Out	9ns (between J29 and J4)

Figure 3 - Clock Architecture Main Characteristics.

2.3 FPGA Design

2.3.1 Control Register Settings

The Control Registers control the complete functionality of the *SMT941*. They are setup via the Comport3 (standard firmware provided). The settings of the ADCs, triggers, clocks and the configuration of the interfaces and the internal FPGA data path settings can be configured via the Control Registers.

2.3.1.1 Control Packet Structure

The data passed on to the *SMT941* over the Comport must conform to a certain packet structure. Only valid packets will be accepted and only after acceptance of a packet will the appropriate settings be implemented. Each packet will start with a command (4 bits - 0x1 for a write operation - 0x2 for a read operation) information, followed by a register address (12 bits - see table Memory Map), followed by a 16-bit data. This structure is illustrated in the following figure:

	Byte Content
--	--------------

Byte	Bit 7	Bit 6	Bit 5	Bit 4	Bit 3	Bit 2	Bit 1	Bit 0
3	Command 3	Command 2	Command 1	Command 0	Address 11	Address 10	Address 9	Address 8
2	Address 7	Address 6	Address 5	Address 4	Address 3	Address 2	Address 1	Address 0
1	Data 15	Data 14	Data 13	Data 12	Data 11	Data 10	Data 9	Data 8
0	Data 7	Data 6	Data 5	Data 4	Data 3	Data 2	Data 1	Data 0

Figure 4 – Setup Packet Structure.

2.3.1.2 Reading and Writing Registers

Control packets are sent to the *SMT941* over ComPort3. This is a bi-directional interface. The format of a 'Read Packet' is the same as that of a write packet.

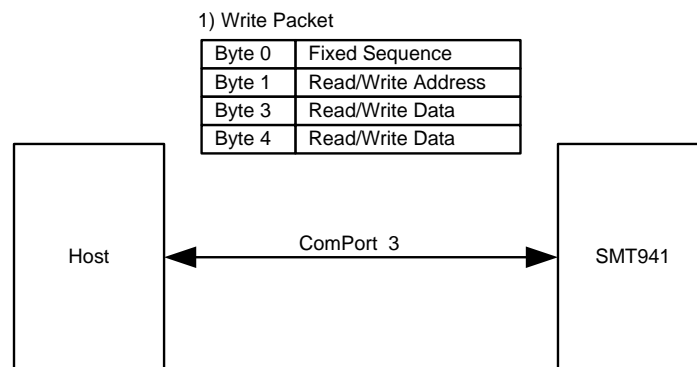

Figure 5 – Control Register Read Sequence.

2.3.1.3 Memory Map

The write packets must contain the address where the data must be written to and the read packets must contain the address where the required data must be read. The following figure shows the memory map for the writable and readable Control Registers on the *SMT941*:

Address	Writable Registers	Readable Registers
0x00	Reserved.	Reserved.
0x01	Board Control Register.	Firmware Version.
0x02	Reserved.	Clock Readback Register.
0x03	Reserved.	Board Status Register
Clock Section		
0x10	Clock Register 0x0.	Read-back (FPGA Register) Clock Register 0x0.
0x11	Clock Register 0x1.	Read-back (FPGA Register) Clock Register 0x1.
...
0x28	Clock Register 0x18.	Read-back (FPGA Register) Clock Register 0x18.

0x29	Clock Register 0x19.	Read-back (FPGA Register) Clock Register 0x19.
0x2A	Clock Readback Address Register (LSB)	
0x2B	Clock Readback Address Register (MSB)	
ADCab Section		
0x30	ADCab Register 0x0.	Read-back (FPGA Register) ADCab Register 0x0.
0x31	ADCab Register 0x1.	Read-back (FPGA Register) ADCab Register 0x1.
...
0x38	ADCab Register 0x8.	Read-back (FPGA Register) ADCab Register 0x8.
0x39	ADCab Register 0x9.	Read-back (FPGA Register) ADCab Register 0x9.
ADCcd Section		
0x40	ADCcd Register 0x0.	Read-back (FPGA Register) ADCcd Register 0x0.
0x41	ADCcd Register 0x1.	Read-back (FPGA Register) ADCcd Register 0x1.
...
0x48	ADCcd Register 0x8.	Read-back (FPGA Register) ADCcd Register 0x8.
0x49	ADCcd Register 0x9.	Read-back (FPGA Register) ADCcd Register 0x9.

Figure 6 – Register Memory Map.

2.3.2 Register Descriptions

Control Register – 0x1.

Control Register – 0x01								
Byte	Bit 7	Bit 6	Bit 5	Bit 4	Bit 3	Bit 2	Bit 1	Bit 0
1								Clk_Readback
Default	'0'	'0'	'0'	'0'	'0'	'0'	'0'	'0'
0	Chcd trigger selection	Chdc internal trigger	Chab trigger selection	Chab internal trigger	Chab reset	Chcd update (dac)	Chab update (adc)	clk update
Default	'0'	'0'	'0'	'0'	'0'	'0'	'0'	'0'

Clock Register 0 – 0x10		
Setting	Bit 0	Description clk update – clock chip register update
0	0	No action.
1	1	All clock registers are sent to the clock chip via its serial interface.
Setting	Bit 1	Description chab update – channel a and b register update
0	0	No action.
1	1	All registers (chab) are sent to the converter via its serial interface.
Setting	Bit 2	Description chcd update – channel c and d register update
0	1	No action.
1	1	All registers (chcd) are sent to the converter via its serial interface.
Setting	Bit 4	Description chab Internal trigger
0	0	No action.
1	1	Starts the data flow (converter chab).

Setting	Bit 5	Description chab trigger selection
0	0	Trigger from control register selected.
1	1	Trigger from external source selected.
Setting	Bit 6	Description chcd Internal trigger
0	0	No action.
1	1	Starts the data flow (converter chcd).
Setting	Bit 7	Description chcd trigger selection
0	0	Trigger from control register selected.
1	1	Trigger from external source selected.

CLOCK Register 0 – 0x10.

Clock Register 0 – 0x10								
Byte	Bit 7	Bit 6	Bit 5	Bit 4	Bit 3	Bit 2	Bit 1	Bit 0
1	Reserved	Reserved	CP_DIR	CP_MODE	DELAY_PFD		REFSELCNTRL	VCXO_AUX_SEL
Default	'0'	'0'	'0'	'0'	'00'		'0'	'0'
0	SECSEL_PRISEL		Reserved		Reserved			
Default	'00'		'00'		'0000'			

Clock Register 0 – 0x10		
Setting	Bit 7:6	Description SECSEL_PRISEL – Reference Input Selection
0	00	Nothing Selected
1	01	On-board Reference selected
2	10	External Reference selected
3	11	Auto Selection (Not recommended)
Setting	Bit 8	Description VCXO_AUX_SEL – VCXO/AUX Selection
0	0	On-board or External Reference. Selected (SECSEL_PRI_SEL)
1	1	On-board VCXO or External Clock selected.
Setting	Bit 9	Description REFSELCNTRL – Reference selection mode
0	0	Reference selection made externally.
1	1	Reference selection made internally (using SECSEL_PRISEL.).
Setting	Bit 11:10	Description DELAY_PFD – PFD pulse width
0	00	
1	01	
2	10	
3	11	
Setting	Bit 12	Description CP_MODE
0	0	3V.
1	1	5V
Setting	Bit 13	Description CP_DIR
0	0	Positive CP current output
1	1	Negative CP current output

CLOCK Register 1 – 0x11.

Clock Register 1 – 0x11								
Byte	Bit 7	Bit 6	Bit 5	Bit 4	Bit 3	Bit 2	Bit 1	Bit 0
1	Output0 (DAC chc&d clk1) Mode						PECLOHISWING	Reserved
Default	'100000'						'0'	'0'
0	Reserved		ICP				CP_PRE	Reserved
Default	'00'		'0000'				'0'	'0'

Reset Register 1 – 0x11		
Setting	Bit 1	Description CP_PRE - Preset charge pump output voltage to vcc/2
0	0	OFF.
1	1	ON.
Setting	Bit 5:2	Description ICP – Charge pump current setting
0	0	
1	1	
Setting	Bit 9	Description PECLOHISWING – PECL output voltage swing (DAC chc&d clk1)
0	0	Normal Operation.
1	1	High PECL output voltage.
Setting	Bit 15:10	Description Output0 (DAC chc&d clk1) mode
0	0	LVPECL only: '100000'.

CLOCK Register 2 – 0x12.

Clock Register 2 – 0x12								
Byte	Bit 7	Bit 6	Bit 5	Bit 4	Bit 3	Bit 2	Bit 1	Bit 0
1	Coarse Phase Adjustment[5:0] (Output DAC chc&d clk1 and clk2)						Reserved	
Default	'000000'						'00'	
0	Reserved				Reserved			
Default	'0011'				'0001'			

Reset Register 2 – 0x12		
Setting	Bit 15:10	Description Coarse Phase Adjustment[5:0] DAC chc&d clk1 and clk2
0	0	
1	1	

CLOCK Register 3 – 0x13.

Clock Register 3 – 0x13								
Byte	Bit 7	Bit 6	Bit 5	Bit 4	Bit 3	Bit 2	Bit 1	Bit 0

1	Output0 (DAC chc&d clk2) Mode	PECL1HISWING	Output Divider Enable
Default	'100000'	'0'	'0'
0	Output Divider Ratio DAC chc&d clk1 and clk2		Coarse Phase Adjustment[6]
Default	'0000000'		'0'

Reset Register 3 – 0x13		
Setting	Bit 0	Description - Coarse Phase Adjustment[6] DAC chc&d clk1 and clk2
0	0	
1	1	
Setting	Bit 7:1	Description – Output Divider Ratio DAC chc&d clk1 and clk2
0	0	
1	1	
Setting	Bit 8	Description – Output Divider Enable DAC chc&d clk1 and clk2
0	0	Divider disabled.
1	1	Divider enabled.
Setting	Bit 9	Description PECL1HISWING – PECL output voltage swing (DAC chc&d clk2)
0	0	Normal Operation.
1	1	High PECL output voltage.
Setting	Bit 15:10	Description Output1 (DAC chc&d clk2) mode
0	0	LVPECL only: '100000'.

CLOCK Register 4 – 0x14.

Clock Register 4 – 0x14								
Byte	Bit 7	Bit 6	Bit 5	Bit 4	Bit 3	Bit 2	Bit 1	Bit 0
1	Coarse Phase Adjustment[5:0] (Output DAC cha&b clk1)						Delay N[2:1]	
Default	'000000'						'00'	
0	Delay N[0]	Delay M			Reserved			
Default	'0'	'0'			'0010'			

Reset Register 4 – 0x14		
Setting	Bit 6:4	Description – Delay M
0	0	
1	1	
Setting	Bit 9:7	Description – Delay N
0	0	
1	1	
Setting	Bit 15:10	Description Coarse Phase Adjustment[5:0] DAC cha&b clk1
0	0	
1	1	

CLOCK Register 5 – 0x15.

Clock Register 5 – 0x15								
Byte	Bit 7	Bit 6	Bit 5	Bit 4	Bit 3	Bit 2	Bit 1	Bit 0
1	Output0 (DAC cha&b clk1) Mode						PECL2HISWING	Output Divider Enable
Default	'100000'						'0'	'0'
0	Output Divider Ratio DAC cha&b clk1							Coarse Phase Adjustment[6]
Default	'0000000'							'0'

Reset Register 5 – 0x15		
Setting	Bit 0	Description - Coarse Phase Adjustment[6] DAC cha&b clk1
0	0	
1	1	
Setting	Bit 7:1	Description – Output Divider Ratio DAC cha&b clk1
0	0	
1	1	
Setting	Bit 8	Description – Output Divider Enable DAC cha&b clk1
0	0	Divider disabled.
1	1	Divider enabled.
Setting	Bit 9	Description PECL2HISWING – PECL output voltage swing (DAC cha&b clk1)
0	0	Normal Operation.
1	1	High PECL output voltage.
Setting	Bit 15:10	Description Output2 (DAC cha&b clk1) mode
0	0	LVPECL only: '100000'.

CLOCK Register 6 – 0x16.

Clock Register 6 – 0x16									
Byte	Bit 7	Bit 6	Bit 5	Bit 4	Bit 3	Bit 2	Bit 1	Bit 0	
1	Coarse Phase Adjustment[5:0] (Output DAC cha&b clk2)						BIAS_DIV23		
Default	'000000'						'00'		
0	BIAS_DIV01		Reserved	DIS_FDET_REF	Reserved				
Default	'00'		'0'	'0'	'0011'				

Reset Register 6 – 0x16		
Setting	Bit 4	Description – DIS_FDET_REF
0	0	Reference Clock detector is ON
1	1	Reference Clock detector is OFF
Setting	Bit 7:6	Description – BIAS_DIV01 – Current reduction output dividers 0 and 1
0	'00'	No current output reduction
1	'01'	20% output current reduction

2	'10'	30% output current reduction
Setting	Bit 9:8	Description – BIAS_DIV23 – Current reduction output dividers 2 and 3
0	'00'	No current output reduction
1	'01'	20% output current reduction
2	'10'	30% output current reduction
Setting	Bit 15:10	Description Coarse Phase Adjustment[5:0] DAC cha&b clk1
0	0	
1	1	

CLOCK Register 7 – 0x17.

Clock Register 7 – 0x17								
Byte	Bit 7	Bit 6	Bit 5	Bit 4	Bit 3	Bit 2	Bit 1	Bit 0
1	Output0 (DAC cha&b clk2) Mode						PECL3HISWING	Output Divider Enable
Default	'100000'						'0'	'0'
0	Output Divider Ratio DAC cha&b clk1 and clk2							Coarse Phase Adjustment[6]
Default	'0000000'							'0'

Reset Register 7 – 0x17		
Setting	Bit 0	Description – Coarse Phase Adjustment[6] DAC cha&b clk2
0	0	
1	1	
Setting	Bit 7:1	Description – Output Divider Ratio DAC cha&b clk2
0	0	
1	1	
Setting	Bit 8	Description – Output Divider Enable DAC cha&b clk2
0	0	Divider disabled.
1	1	Divider enabled.
Setting	Bit 9	Description PECL3HISWING – PECL output voltage swing (DAC cha&b clk2)
0	0	Normal Operation.
1	1	High PECL output voltage.
Setting	Bit 15:10	Description Output3 (DAC cha&b clk2) mode
0	0	LVPECL only: '100000'.

CLOCK Register 8 – 0x18.

Clock Register 8 – 0x18								
Byte	Bit 7	Bit 6	Bit 5	Bit 4	Bit 3	Bit 2	Bit 1	Bit 0
1	Coarse Phase Adjustment[5:0] (External Clock)						Reserved	HOLD_ON_LOR
Default	'000000'						'0'	'0'
0	Reserved				Reserved			
Default	'0000'				'0011'			

Reset Register 8 – 0x18		
Setting	Bit 8	Description – HOLD_ON_LOR
0	0	Normal mode of operation
1	1	Charge pump in tri-state mode
Setting	Bit 15:10	Description Coarse Phase Adjustment[5:0] External Clock
0	0	
1	1	

CLOCK Register 9 – 0x19.

Clock Register 9 – 0x19								
Byte	Bit 7	Bit 6	Bit 5	Bit 4	Bit 3	Bit 2	Bit 1	Bit 0
1	Output0 (External Clock) Mode						PECL4HISWING	Output Divider Enable
Default	'100000'						'0'	'0'
0	Output Divider Ratio External Clock							Coarse Phase Adjustment[6]
Default	'0000000'							'0'

Reset Register 9 – 0x19		
Setting	Bit 0	Description - Coarse Phase Adjustment[6] External Clock
0	0	
1	1	
Setting	Bit 7:1	Description – Output Divider Ratio External Clock
0	0	
1	1	
Setting	Bit 8	Description – Output Divider Enable External Clock
0	0	Divider disabled.
1	1	Divider enabled.
Setting	Bit 9	Description PECL4HISWING – PECL output voltage swing (External Clock)
0	0	Normal Operation.
1	1	High PECL output voltage.
Setting	Bit 15:10	Description Output4 (External Clock) mode
0	0	LVPECL only: '100000'.

CLOCK Register A – 0x1A.

Clock Register A – 0x1A								
Byte	Bit 7	Bit 6	Bit 5	Bit 4	Bit 3	Bit 2	Bit 1	Bit 0
1	Reserved						Reserved	
Default	'000000'						'00'	

0	Reserved	BIAS_DIV45	Reserved
Default	'00'	'00'	'0101'

Reset Register A – 0x1A		
Setting	Bit 5:4	Description – BIAS_DIV01 – Current reduction output dividers 0 and 1
0	'00'	No current output reduction
1	'01'	20% output current reduction
2	'10'	30% output current reduction

CLOCK Register B – 0x1B.

Clock Register B – 0x1B								
Byte	Bit 7	Bit 6	Bit 5	Bit 4	Bit 3	Bit 2	Bit 1	Bit 0
1	Reserved							
Default	'01101000'							
0	Reserved							
Default	'00000000'							

CLOCK Register C – 0x1C.

Clock Register C – 0x1C								
Byte	Bit 7	Bit 6	Bit 5	Bit 4	Bit 3	Bit 2	Bit 1	Bit 0
1	Reserved						DET_START_BYPASS	FB_START_BYPASS
Default	'000000'						'0'	'0'
0	DIV2_DIS	DIV_SEL	Reserved	FB_FD_DESEL	Reserved			
Default	'0'	'0'	'0'	'0'	'0110'			

Reset Register C – 0x1C		
Setting	Bit 4	Description – FB_FD_DESEL
0	'0'	Feedback frequency detector is connected to the lock detector
1	'1'	Feedback frequency detector is disconnected from the lock detector
Setting	Bit 6	Description – DIV_SEL
0	'0'	FB Clock divided by 1
1	'1'	FB Clock divided by 2
Setting	Bit 7	Description – DIV2_DIS
0	'0'	Normal mode of operation
1	'1'	FB Div2 in reset
Setting	Bit 8	Description – FB_START_BYPASS
0	'0'	Normal mode of operation
1	'1'	FB Divider can be started with external REF_SEL (pin)
Setting	Bit 9	Description – DET_START_BYPASS

0	'0'	Normal mode of operation
1	'1'	FB Divider can be started with external NRESET (pin)

CLOCK Register D – 0x1D.

Clock Register D – 0x1D								
Byte	Bit 7	Bit 6	Bit 5	Bit 4	Bit 3	Bit 2	Bit 1	Bit 0
1	Reserved							
Default	'01101000'							
0	Reserved							
Default	'00000000'							

CLOCK Register E – 0x1E.

Clock Register E – 0x1E								
Byte	Bit 7	Bit 6	Bit 5	Bit 4	Bit 3	Bit 2	Bit 1	Bit 0
1	Reserved						ADLOCK	LOCK_C[1]
Default	'000000'						'0'	'0'
0	LOCK_C[0]	Reserved	LOCK_WINDOW		Reserved			
Default	'0'	'0'	'00'		'0111'			

Reset Register E – 0x1E		
Setting	Bit 5:4	Description – Lock detect window – LOCK_WINDOW
0	'0'	
1	'1'	
Setting	Bit 8:7	Description – Number of coherent lock events – LOCK_C
0	'0'	
1	'1'	
Setting	Bit 9	Description ADLOCK
0	'0'	Digital PLL Lock
1	'1'	Analog PLL Lock

CLOCK Register F – 0x1F.

Clock Register F – 0x1F								
Byte	Bit 7	Bit 6	Bit 5	Bit 4	Bit 3	Bit 2	Bit 1	Bit 0
1	Reserved							
Default	'01101000'							
0	Reserved							
Default	'00000000'							

CLOCK Register 10 – 0x20.

Clock Register 10 – 0x20								
Byte	Bit 7	Bit 6	Bit 5	Bit 4	Bit 3	Bit 2	Bit 1	Bit 0
1	Reserved							
Default	'00000001'							
0	Reserved				Reserved			
Default	'0111'				'1000'			

CLOCK Register 11 – 0x21.

Clock Register 11 – 0x21								
Byte	Bit 7	Bit 6	Bit 5	Bit 4	Bit 3	Bit 2	Bit 1	Bit 0
1	Reserved							
Default	'01101000'							
0	Reserved				Reserved			
Default	'0000'				'0000'			

CLOCK Register 12 – 0x22.

Clock Register 12 – 0x22								
Byte	Bit 7	Bit 6	Bit 5	Bit 4	Bit 3	Bit 2	Bit 1	Bit 0
1	INDET_BP	START_BYPASS	DIVSYNC_DIS	Reserved	LOCKW		HOLD_CNT	
Default	'0'	'0'	'0'	'0'	'00'		'00'	
0	Reserved	HOLD	Reserved	HOLDF	Reserved			
Default	'0'	'0'	'0'	'0'	'1001'			

Reset Register 12 – 0x22		
Setting	Bit 4	Description – Frequency Hold Over (External) enable – HOLDF
0	'0'	Off
1	'1'	On
Setting	Bit 6	Description – equals to HOLD pin – HOLD
0	'0'	Tri-state charge pump
1	'1'	
Setting	Bit 6	Description – equals to HOLD pin – HOLD
0	'0'	Tri-state charge pump
1	'1'	
Setting	Bit 9:8	Description – Hold function reactivates after a number of reference clock cycles – HOLD_CNT
0	'00'	64 clock cycles
1	'01'	128 clock cycles
2	'10'	256 clock cycles
3	'11'	512 clock cycles

Setting	Bit 11:10	Description – Extended lock detect window - LOCKW
0	'00'	
1	'01'	
2	'10'	
3	'11'	
Setting	Bit 13	Description – DIVSYNC_DIS
0	'0'	Start signal is synchronised to N/M divider input clock
1	'1'	
Setting	Bit 14	Description – START_BYPASS
0	'0'	Start signal is synchronised to VCXO clock
1	'1'	Start synch block is bypassed
Setting	Bit 15	Description – INDET_BP
0	'0'	Synch logic active when VCXO/AUX clocks are available
1	'1'	Synch logic is independent from VCXO/AUX

CLOCK Register 13 – 0x23.

Clock Register 13 – 0x23									
Byte	Bit 7	Bit 6	Bit 5	Bit 4	Bit 3	Bit 2	Bit 1	Bit 0	
1	Reserved								
Default	'00000000'								
0	Reserved			BIAS_DIV_FB		NPRESET_MDIV	LOW_FD_FB_EN	PLL_LOCK_BP	
Default	'000'			'00'		'0'	'0'	'0'	

Reset Register 13 – 0x23		
Setting	Bit 0	Description – PLL_LOCK_BP
0	'0'	Synch logic waits for the first PLL lock state
1	'1'	Synch logic independent from first PLL lock state
Setting	Bit 1	Description – LOW_FD_FB_EN
0	'0'	Synch logic is independent from VCXO/DIV_FB frequency
1	'1'	Synch logic is started for VCXO/DIV_FB > 600khz
Setting	Bit 2	Description – NPRESET_MDIV
0	'0'	M-divider uses nHOLD as NPRESET
1	'1'	M-divider not preset by nHOLD
Setting	Bit 4:3	Description – BIAS_DIV_FB
0	'00'	No current reduction
1	'01'	20% current reduction
2	'10'	30% current reduction

CLOCK Register 14 – 0x24.

Clock Register 14 – 0x24								
Byte	Bit 7	Bit 6	Bit 5	Bit 4	Bit 3	Bit 2	Bit 1	Bit 0
1	Reference Divider[11:4]							

Default	'00000000'	
0	Reference Divider M[3:0]	Reserved
Default	'0000'	'1010'

Reset Register 14 – 0x24		
Setting	Bit 11:4	Description – Reference Divider M[11:0]
0		
1		

CLOCK Register 15 – 0x25.

Clock Register 15 – 0x25								
Byte	Bit 7	Bit 6	Bit 5	Bit 4	Bit 3	Bit 2	Bit 1	Bit 0
1	VCXO Divider N[13:6]							
Default	'000000'							
0	VCXO Divider N[5:0]						Reference Divider M[13:12]	
Default	'000000'						'00'	

Reset Register 15 – 0x25		
Setting	Bit 1:0	Description – Reference Divider M[13:12]
0		
1		
Setting	Bit 15:2	Description – VCXO Divider N[13:0]
0		
1		

CLOCK Register 16 – 0x26.

Clock Register 16 – 0x26								
Byte	Bit 7	Bit 6	Bit 5	Bit 4	Bit 3	Bit 2	Bit 1	Bit 0
1	FB_COUNTER							FB_INCLK_I NV
Default	'00000000'							'0'
0	FB_CML_SE L	FB_DIS	SEC_DIV2	PRI_DIV2	Reserved			
Default	'0'	'0'	'0'	'0'	'1011'			

Reset Register 16 – 0x26		
Setting	Bit 4	Description – PRI_DIV2
0	'0'	Primary reference divider disabled
1	'1'	Primary reference divider enabled
Setting	Bit 5	Description – SEC_DIV2
0	'0'	Secondary reference divider disabled

1	'1'	Secondary reference divider enabled
Setting	Bit 6	Description – FB_DIS
0	'0'	FB Divider is active
1	'1'	FB Divider is disabled
Setting	Bit 7	Description – FB_CML_SEL
0	'0'	FB is CMOS type
1	'1'	FB is CML type
Setting	Bit 8	Description – FB_INCLK_INV
0	'0'	Input clock for FB not inverted (normal/low speed mode)
1	'1'	Input for FB inverted (high speed mode)
Setting	Bit 15:9	Description – FB_COUNTER
0	'0'	FB Path integer counter
1		

CLOCK Register 17 – 0x27.

Clock Register 17 – 0x27								
Byte	Bit 7	Bit 6	Bit 5	Bit 4	Bit 3	Bit 2	Bit 1	Bit 0
1				RESET_HOLD	SEL_DELAY	RESHAPE	Reserved	OUT_MUX_SEL
Default				'0'	'0'	'0'	'0'	'0'
0	FB_MUX_SEL	PD_PLL	FB_PHASE_ADJ					
Default	'0'	'0'	'000000'					

Reset Register 17 – 0x27		
Setting	Bit 5:0	Description – FB_PHASE_ADJ
0	'0'	Feedback phase adjustment
Setting	Bit 6	Description – PD_PLL
0	'0'	PLL in normal mode
1	'1'	PLL powered down
Setting	Bit 7	Description – FB_MUX_SEL
0	'0'	VCXO selected for clock tree and FB
1	'1'	External Clock selected for clock tree and FB
Setting	Bit 8	Description – OUT_MUX_SEL
0	'0'	VCXO selected
1	'1'	External clock selected
Setting	Bit 10	Description – RESHAPE
0	'0'	Reference clock reshaped
1	'1'	Reference clock not reshaped
Setting	Bit 11	Description – SEL_DELAY
0	'0'	Enables short delay for fast operation
1	'1'	Long delay - recommended for reference below 150mhz.
Setting	Bit 12	Description – RESET_HOLD
0	'0'	RESET or HOLD acts as nRESET pin

1	'1'	RESET or HOLD acts as nHOLD pin
---	-----	---------------------------------

CLOCK Register 18 – 0x28.

Clock Register 18 – 0x28								
Byte	Bit 7	Bit 6	Bit 5	Bit 4	Bit 3	Bit 2	Bit 1	Bit 0
1	Reserved			nRESET_nHOLD	nPD	Reserved		
Default	'000'			'0'	'1'	'000'		
0	Reserved				Reserved			
Default	'0000'				'1100'			

Reset Register 18 – 0x28		
Setting	Bit 11	Description – nPD
0	'0'	Power-down mode active
1	'1'	Normal mode of operation
Setting	Bit 12	Description – nRESET_nHOLD
0	'0'	Forces RESET or HOLD
1	'1'	Normal mode of operation

CLOCK Register 19 – 0x29.

Clock Register 19 – 0x29								
Byte	Bit 7	Bit 6	Bit 5	Bit 4	Bit 3	Bit 2	Bit 1	Bit 0
1								
Default								
0								
Default								

Reset Register 19 – 0x29		
Setting	Bit 11	Description – nPD
0		
1		
Setting	Bit 12	Description – nRESET_nHOLD
0		
1		

ADC Chab Register 0 – 0x30.

ADC Chab Register 0 – 0x30								
Byte	Bit 7	Bit 6	Bit 5	Bit 4	Bit 3	Bit 2	Bit 1	Bit 0
1	Reserved					Enable Low Speed Mode	Reserved	
Default	'00000'					'0'	'00'	
0	Software Reset	Reserved						SerialRead Out
Default	'0'	'000000'						'0'

ADC Chab Register 0 – 0x30		
Setting	Bit 0	Description – SerialReadOut
0	'0'	Serial readout disabled.
1	'1'	Serial readout enabled.
Setting	Bit 7	Description - Software Reset
0	'0'	Normal mode of operation.
1	'1'	Resets all internal registers and self-clears to '0'.
Setting	Bit 10	Description - Enable Low Speed Mode
0	'0'	Low Speed Mode disabled. Sampling rates >100MSPS.
0	'1'	Low Speed Mode enabled. Sampling rates <=100 MSPS.

ADC Chab Register 1 – 0x31.

ADC Chab Register 1 – 0x31								
Byte	Bit 7	Bit 6	Bit 5	Bit 4	Bit 3	Bit 2	Bit 1	Bit 0
0	Reserved	Reference		Reserved			Standby	Reserved
Default	'0'	'00'		'000'			'0'	'0'
1	Reserved				PowerDownModes			
Default	'0000'				'0000'			

ADC Chab Register 1 – 0x31		
Setting	Bit 1	Description – Standby.
0	'0'	Normal mode of operation.

1	'1'	Both ADC channels are put into standby mode (internal ref and output buffers still active).
Setting	Bit 6:5	Description – Reference.
0	'01'	Internal Reference enabled.
1	'11'	External Reference enabled.
Setting	Bit 11:8	Description – Power down modes.
0	'0000'	Pins ctrl1, 2 and 3 determine power down modes.
1	'1000'	Normal mode of operation.
2	'1001'	Output buffers disabled for channelB.
3	'1010'	Output buffers disabled for channelA.
4	'1011'	Output buffers disabled for channelA and B.
5	'1100'	Global power down.
6	'1101'	ChannelB in standby.
7	'1110'	ChannelA in standby.

ADC Chab Register 2 – 0x32.

ADC Chab Register 2 – 0x32								
Byte	Bit 7	Bit 6	Bit 5	Bit 4	Bit 3	Bit 2	Bit 1	Bit 0
0	LVDS_CM OS	Reserved						
Default	'0'	'0000000'						
1	Clock Edge Control (rising edge)			Clock Edge Control (falling edge)			Reserved	
Default	'000'			'000'			'00'	

ADC Chab Register 2 – 0x32		
Setting	Bit 7	Description – LVDS_CMOS
0	'0'	Parallel CMOS interface.
1	'1'	DDR LVDS interface.
Setting	Bit 12:10	Description – Clock output Edge control (falling edge)
0	'000','100'	Default output clock position.
1	'101'	Falling edge shifted by $+(4/26)/\text{Sampling Frequency}$
2	'110'	Falling edge shifted by $-(6/26)/\text{Sampling Frequency}$
3	'111'	Falling edge shifted by $-(4/26)/\text{Sampling Frequency}$
Setting	Bit 15:13	Description – Clock output Edge control (rising edge)
0	'000','100'	Default output clock position.
1	'101'	Rising edge shifted by $+(4/26)/\text{Sampling Frequency}$
2	'110'	Rising edge shifted by $-(6/26)/\text{Sampling Frequency}$
3	'111'	Rising edge shifted by $-(4/26)/\text{Sampling Frequency}$

ADC Chab Register 3 – 0x33.

ADC Chab Register 3 – 0x33	

Byte	Bit 7	Bit 6	Bit 5	Bit 4	Bit 3	Bit 2	Bit 1	Bit 0
0	Reserved	Channel Control	Reserved			Data Format		Reserved
Default	'0'	'0'	'000'			'00'		'0'
1	Custom Pattern (lsb)							
Default	'00000000'							

ADC Chab Register 3 – 0x33		
Setting	Bit 2:1	Description – Data Format
0	'10'	2's complement.
1	'11'	Binary.
Setting	Bit 6	Description - Channel Control
0	'0'	Common Control.
1	'1'	Independent Control (Test pattern, Offset correction and SNR boost).
Setting	Bit 15:8	Description – Custom Pattern (lsb)
0		

ADC Chab Register 4 – 0x34.

ADC Chab Register 4 – 0x34								
Byte	Bit 7	Bit 6	Bit 5	Bit 4	Bit 3	Bit 2	Bit 1	Bit 0
0	Reserved		Custom Pattern (msb)					
Default	'00'		'000000'					
1	Reserved	Offset Correction Enable	Reserved					
Default	'0'	'0'	'000000'					

ADC Chab Register 4– 0x34		
Setting	Bit 5:0	Description – Custom Pattern (msb).
0		
Setting	Bit 14	Description – Offset Correction Enable ChA.
0	'0'	Offset Correction Disabled.
1	'1'	Offset Correction Enabled.

ADC Chab Register 5 – 0x35.

ADC Chab Register 5 – 0x35								
Byte	Bit 7	Bit 6	Bit 5	Bit 4	Bit 3	Bit 2	Bit 1	Bit 0
0	Gain ChA (Common)				Offset Correction Time Constant ChA			
Default	'0000'				'0000'			
1	Reserved	Fine Gain Adjustment ChA (Common)						

Default	'0'	'0000000'
---------	-----	-----------

ADC Chab Register 5- 0x35		
Setting	Bit 3:0	Description - Offset Correction Time Constant (number of clock cycles) ChA
0	'0000'	256k
1	'0001'	512k
2	'0010'	1Meg
3	'0011'	2Meg
4	'0100'	4Meg
5	'0101'	8Meg
6	'0110'	16Meg
7	'0111'	32Meg
8	'1000'	64Meg
9	'1001'	128Meg
10	'1010'	256Meg
11	'1011'	512Meg
Setting	Bit 7:4	Description - Gain ChA (Common).
0	'0000'	0dB gain
1	'0001'	0.5dB gain
2	'0010'	1.0dB gain
3	'0011'	1.5dB gain
4	'0100'	2.0dB gain
5	'0101'	2.5dB gain
6	'0110'	3.0dB gain
7	'0111'	3.5dB gain
8	'1000'	4.0dB gain
9	'1001'	4.5dB gain
10	'1010'	5.0dB gain
11	'1011'	5.5dB gain
12	'1100'	6.0dB gain
Setting	Bit 14:8	Description - Fine Gain ChA (Common).
0		128 steps for a range of 0.134dB

ADC Chab Register 6 - 0x36.

ADC Chab Register 6 - 0x36								
Byte	Bit 7	Bit 6	Bit 5	Bit 4	Bit 3	Bit 2	Bit 1	Bit 0
0	Reserved					Test Patterns ChA		
Default	'00000'					'000'		
1	Reserved		Offset Pedestal ChA (Common)					
Default	'00'							

ADC Chab Register 6– 0x36		
Setting	Bit 2:0	Description – Test Patterns ChA
0	'000'	Normal Mode of Operation
1	'001'	Outputs all zeroes
2	'010'	Outputs all ones
3	'011'	Outputs toggle pattern (0x1555 and 0x2AAA)
4	'100'	Outputs digital ramp (0->16383)
5	'101'	Outputs custom pattern
Setting	Bit 13:8	Description – Offset Pedestal ChA (Common)
0	'011111'	Pedestal=+31LSBs
1	'011110'	Pedestal=+30LSBs
2
3	'000000'	Pedestal=0
4
5	'111111'	Pedestal=-1LSB
6	'111110'	Pedestal=-2LSB
7
8	'100000'	-32LSBs

ADC Chab Register 7 – 0x37.

ADC Chab Register 7 – 0x37								
Byte	Bit 7	Bit 6	Bit 5	Bit 4	Bit 3	Bit 2	Bit 1	Bit 0
0	Reserved	Offset Correction Enable ChB	Reserved					
Default	'0'	'0'	'000000'					
1	Gain ChB (Common)				Offset Correction Time Constant ChB			
Default	'0000'				'0000'			

ADC Chab Register 7– 0x37		
Setting	Bit 6	Description – Offset Correction Enable ChB.
0	'0'	Offset Correction Disabled.
1	'1'	Offset Correction Enabled.
Setting	Bit 11:8	Description – Offset Correction Time Constant (number of clock cycles) ChB
0	'0000'	256k
1	'0001'	512k
2	'0010'	1Meg
3	'0011'	2Meg
4	'0100'	4Meg
5	'0101'	8Meg

6	'0110'	16Meg
7	'0111'	32Meg
8	'1000'	64Meg
9	'1001'	128Meg
10	'1010'	256Meg
11	'1011'	512Meg
Setting	Bit 15:12	Description – Gain ChB (Common).
0	'0000'	0dB gain
1	'0001'	0.5dB gain
2	'0010'	1.0dB gain
3	'0011'	1.5dB gain
4	'0100'	2.0dB gain
5	'0101'	2.5dB gain
6	'0110'	3.0dB gain
7	'0111'	3.5dB gain
8	'1000'	4.0dB gain
9	'1001'	4.5dB gain
10	'1010'	5.0dB gain
11	'1011'	5.5dB gain
12	'1100'	6.0dB gain

ADC Chab Register 8 – 0x38.

ADC Chab Register 8 – 0x38								
Byte	Bit 7	Bit 6	Bit 5	Bit 4	Bit 3	Bit 2	Bit 1	Bit 0
0	Reserved	Fine Gain Adjustment ChB						
Default	'0'	'0000000'						
1	Reserved					Test Patterns ChB		
Default	'00000'					'000'		

ADC Chab Register 8– 0x38		
Setting	Bit 6:0	Description – Fine Gain ChB.
0		128 steps for a range of 0.134dB
Setting	Bit 10:8	Description – Test Patterns ChB
0	'000'	Normal Mode of Operation
1	'001'	Outputs all zeroes
2	'010'	Outputs all ones
3	'011'	Outputs toggle pattern (0x1555 and 0x2AAA)
4	'100'	Outputs digital ramp (0->16383)
5	'101'	Outputs custom pattern

ADC Chab Register 9 – 0x39.

ADC Chab Register 9 – 0x39	
----------------------------	--

Byte	Bit 7	Bit 6	Bit 5	Bit 4	Bit 3	Bit 2	Bit 1	Bit 0
0	Reserved		Offset Pedestal ChB (Common)					
Default	'00'							
1	Reserved							
Default	'00000000'							

ADC Chab Register 9 – 0x39		
Setting	Bit 5:0	Description – Offset Pedestal ChA (Common)
0	'011111'	Pedestal=+31LSBs
1	'011110'	Pedestal=+30LSBs
2
3	'000000'	Pedestal=0
4
5	'111111'	Pedestal=-1LSB
6	'111110'	Pedestal=-2LSB
7
8	'100000'	-32LSBs

ADC Chcd Register 0 – 0x40.

ADC Chcd Register 0 – 0x40								
Byte	Bit 7	Bit 6	Bit 5	Bit 4	Bit 3	Bit 2	Bit 1	Bit 0
1	Reserved					Enable Low Speed Mode	Reserved	
Default	'00000'					'0'	'00'	
0	Software Reset	Reserved						SerialRead Out
Default	'0'	'000000'						'0'

ADC Chcd Register 0 – 0x40		
Setting	Bit 0	Description – SerialReadOut
0	'0'	Serial readout disabled.
1	'1'	Serial readout enabled.
Setting	Bit 7	Description – Software Reset
0	'0'	Normal mode of operation.
1	'1'	Resets all internal registers and self-clears to '0'.
Setting	Bit 10	Description – Enable Low Speed Mode
0	'0'	Low Speed Mode disabled. Sampling rates >100MSPS.
0	'1'	Low Speed Mode enabled. Sampling rates <=100 MSPS.

ADC Chcd Register 1 – 0x41.

ADC Chcd Register 1 – 0x41								
Byte	Bit 7	Bit 6	Bit 5	Bit 4	Bit 3	Bit 2	Bit 1	Bit 0
0	Reserved	Reference		Reserved			Standby	Reserved
Default	'0'	'00'		'000'			'0'	'0'
1	Reserved				PowerDownModes			
Default	'0000'				'0000'			

ADC Chcd Register 1 – 0x41		
Setting	Bit 1	Description – Standby.
0	'0'	Normal mode of operation.
1	'1'	Both ADC channels are put into standby mode (internal ref and output buffers still active).
Setting	Bit 6:5	Description – Reference.
0	'01'	Internal Reference enabled.
1	'11'	External Reference enabled.
Setting	Bit 11:8	Description – Power down modes.
0	'0000'	Pins ctrl1, 2 and 3 determine power down modes.
1	'1000'	Normal mode of operation.
2	'1001'	Output buffers disabled for channelB.
3	'1010'	Output buffers disabled for channelA.
4	'1011'	Output buffers disabled for channelA and B.
5	'1100'	Global power down.
6	'1101'	ChannelB in standby.
7	'1110'	ChannelA in standby.

ADC Chcd Register 2 – 0x42.

ADC Chcd Register 2 – 0x42								
Byte	Bit 7	Bit 6	Bit 5	Bit 4	Bit 3	Bit 2	Bit 1	Bit 0
0	LVDS_CMOS	Reserved						
Default	'0'	'0000000'						
1	Clock Edge Control (rising edge)			Clock Edge Control (falling edge)			Reserved	
Default	'000'			'000'			'00'	

ADC Chcd Register 2 – 0x42		
Setting	Bit 7	Description – LVDS_CMOS
0	'0'	Parallel CMOS interface.
1	'1'	DDR LVDS interface.
Setting	Bit 12:10	Description – Clock output Edge control (falling edge)
0	'000','100'	Default output clock position.
1	'101'	Falling edge shifted by $+(4/26)/\text{Sampling Frequency}$
2	'110'	Falling edge shifted by $-(6/26)/\text{Sampling Frequency}$

3	'111'	Falling edge shifted by $-(4/26)/\text{Sampling Frequency}$
Setting	Bit 15:13	Description – Clock output Edge control (rising edge)
0	'000','100'	Default output clock position.
1	'101'	Rising edge shifted by $+(4/26)/\text{Sampling Frequency}$
2	'110'	Rising edge shifted by $-(6/26)/\text{Sampling Frequency}$
3	'111'	Rising edge shifted by $-(4/26)/\text{Sampling Frequency}$

ADC Chcd Register 3 – 0x43.

ADC Chcd Register 3 – 0x43								
Byte	Bit 7	Bit 6	Bit 5	Bit 4	Bit 3	Bit 2	Bit 1	Bit 0
0	Reserved	Channel Control	Reserved			Data Format		Reserved
Default	'0'	'0'	'000'			'00'		'0'
1	Custom Pattern (lsb)							
Default	'00000000'							

ADC Chcd Register 3 – 0x43		
Setting	Bit 2:1	Description – Data Format
0	'10'	2's complement.
1	'11'	Binary.
Setting	Bit 6	Description - Channel Control
0	'0'	Common Control.
1	'1'	Independent Control (Test pattern, Offset correction and SNR boost).
Setting	Bit 15:8	Description – Custom Pattern (lsb)
0		

ADC Chcd Register 4 – 0x44.

ADC Chcd Register 4 – 0x44								
Byte	Bit 7	Bit 6	Bit 5	Bit 4	Bit 3	Bit 2	Bit 1	Bit 0
0	Reserved		Custom Pattern (msb)					
Default	'00'		'000000'					
1	Reserved	Offset Correction Enable	Reserved					
Default	'0'	'0'	'000000'					

ADC Chcd Register 4– 0x44		
Setting	Bit 5:0	Description – Custom Pattern (msb).
0		
Setting	Bit 14	Description – Offset Correction Enable ChA.

0	'0'	Offset Correction Disabled.
1	'1'	Offset Correction Enabled.

ADC Chcd Register 5 – 0x45.

ADC Chcd Register 5 – 0x45								
Byte	Bit 7	Bit 6	Bit 5	Bit 4	Bit 3	Bit 2	Bit 1	Bit 0
0	Gain ChA (Common)				Offset Correction Time Constant ChA			
Default	'0000'				'0000'			
1	Reserved	Fine Gain Adjustment ChA (Common)						
Default	'0'	'0000000'						

ADC Chcd Register 5– 0x45		
Setting	Bit 3:0	Description – Offset Correction Time Constant (number of clock cycles) ChA
0	'0000'	256k
1	'0001'	512k
2	'0010'	1Meg
3	'0011'	2Meg
4	'0100'	4Meg
5	'0101'	8Meg
6	'0110'	16Meg
7	'0111'	32Meg
8	'1000'	64Meg
9	'1001'	128Meg
10	'1010'	256Meg
11	'1011'	512Meg
Setting	Bit 7:4	Description – Gain ChA (Common).
0	'0000'	0dB gain
1	'0001'	0.5dB gain
2	'0010'	1.0dB gain
3	'0011'	1.5dB gain
4	'0100'	2.0dB gain
5	'0101'	2.5dB gain
6	'0110'	3.0dB gain
7	'0111'	3.5dB gain
8	'1000'	4.0dB gain
9	'1001'	4.5dB gain
10	'1010'	5.0dB gain
11	'1011'	5.5dB gain
12	'1100'	6.0dB gain
Setting	Bit 14:8	Description – Fine Gain ChA (Common).

0	128 steps for a range of 0.134dB
---	----------------------------------

ADC Chcd Register 6 – 0x46.

ADC Chcd Register 6 – 0x46								
Byte	Bit 7	Bit 6	Bit 5	Bit 4	Bit 3	Bit 2	Bit 1	Bit 0
0	Reserved					Test Patterns ChA		
Default	'00000'					'000'		
1	Reserved		Offset Pedestal ChA (Common)					
Default	'00'							

ADC Chcd Register 6– 0x46		
Setting	Bit 2:0	Description – Test Patterns ChA
0	'000'	Normal Mode of Operation
1	'001'	Outputs all zeroes
2	'010'	Outputs all ones
3	'011'	Outputs toggle pattern (0x1555 and 0x2AAA)
4	'100'	Outputs digital ramp (0->16383)
5	'101'	Outputs custom pattern
Setting	Bit 13:8	Description – Offset Pedestal ChA (Common)
0	'011111'	Pedestal=+31LSBs
1	'011110'	Pedestal=+30LSBs
2
3	'000000'	Pedestal=0
4
5	'111111'	Pedestal=-1LSB
6	'111110'	Pedestal=-2LSB
7
8	'100000'	-32LSBs

ADC Chcd Register 7 – 0x47.

ADC Chcd Register 7 – 0x47								
Byte	Bit 7	Bit 6	Bit 5	Bit 4	Bit 3	Bit 2	Bit 1	Bit 0
0	Reserved	Offset Correction Enable ChB	Reserved					
Default	'0'	'0'	'000000'					
1	Gain ChB (Common)				Offset Correction Time Constant ChB			
Default	'0000'				'0000'			

ADC Chcd Register 7– 0x47		
Setting	Bit 6	Description – Offset Correction Enable ChB.
0	'0'	Offset Correction Disabled.
1	'1'	Offset Correction Enabled.
Setting	Bit 11:8	Description – Offset Correction Time Constant (number of clock cycles) ChB
0	'0000'	256k
1	'0001'	512k
2	'0010'	1Meg
3	'0011'	2Meg
4	'0100'	4Meg
5	'0101'	8Meg
6	'0110'	16Meg
7	'0111'	32Meg
8	'1000'	64Meg
9	'1001'	128Meg
10	'1010'	256Meg
11	'1011'	512Meg
Setting	Bit 15:12	Description – Gain ChB (Common).
0	'0000'	0dB gain
1	'0001'	0.5dB gain
2	'0010'	1.0dB gain
3	'0011'	1.5dB gain
4	'0100'	2.0dB gain
5	'0101'	2.5dB gain
6	'0110'	3.0dB gain
7	'0111'	3.5dB gain
8	'1000'	4.0dB gain
9	'1001'	4.5dB gain
10	'1010'	5.0dB gain
11	'1011'	5.5dB gain
12	'1100'	6.0dB gain

ADC Chcd Register 8 – 0x48.

ADC Chcd Register 8 – 0x48								
Byte	Bit 7	Bit 6	Bit 5	Bit 4	Bit 3	Bit 2	Bit 1	Bit 0
0	Reserved	Fine Gain Adjustment ChB						
Default	'0'	'0000000'						
1	Reserved					Test Patterns ChB		
Default	'00000'					'000'		

ADC Chcd Register 8– 0x48		
Setting	Bit 6:0	Description – Fine Gain ChB.

0		128 steps for a range of 0.134dB
Setting	Bit 10:8	Description – Test Patterns ChB
0	'000'	Normal Mode of Operation
1	'001'	Outputs all zeroes
2	'010'	Outputs all ones
3	'011'	Outputs toggle pattern (0x1555 and 0x2AAA)
4	'100'	Outputs digital ramp (0->16383)
5	'101'	Outputs custom pattern

ADC Chcd Register 9 – 0x49.

ADC Chcd Register 9 – 0x49								
Byte	Bit 7	Bit 6	Bit 5	Bit 4	Bit 3	Bit 2	Bit 1	Bit 0
0	Reserved		Offset Pedestal ChB (Common)					
Default	'00'							
1	Reserved							
Default	'00000000'							

ADC Chcd Register 9 – 0x49		
Setting	Bit 5:0	Description – Offset Pedestal ChA (Common)
0	'011111'	Pedestal=+31LSBs
1	'011110'	Pedestal=+30LSBs
2
3	'000000'	Pedestal=0
4
5	'111111'	Pedestal=-1LSB
6	'111110'	Pedestal=-2LSB
7
8	'100000'	-32LSBs

3 PCB Layout

3.1 Top View

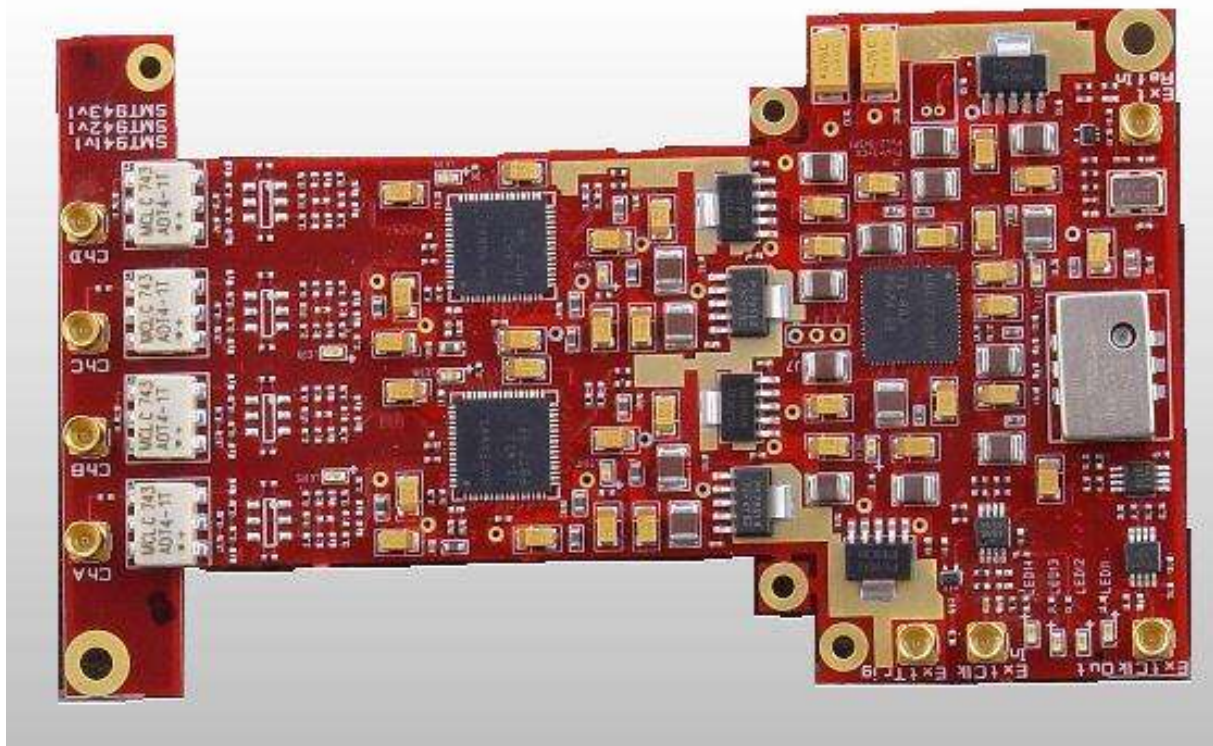

3.2 Bottom View

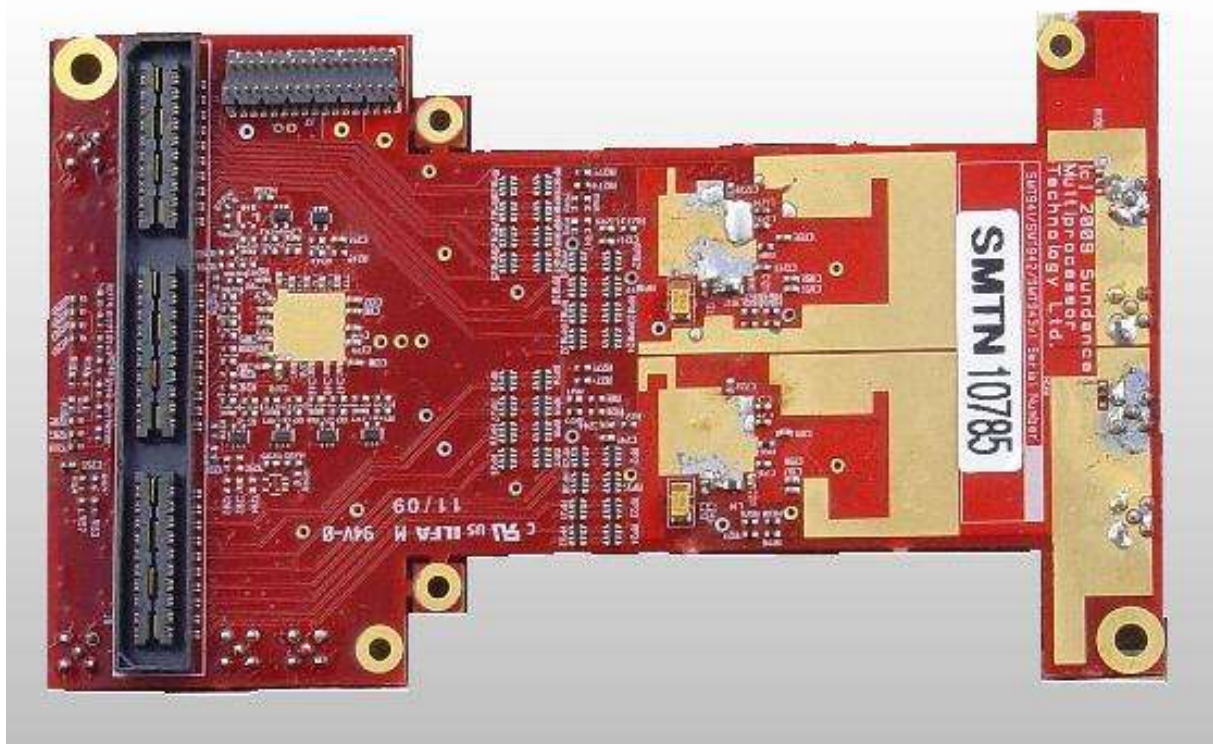

4 Connectors

4.1 Description

The following table gathers all connectors on the board and describes their function.

Connector (silkscreen schematics)	name and	Description	Location on the board
J16		ADCA Analog Input	Top / Left
J15		ADCB Analog Input	Top / Left
J1016		ADCC Analog Input	Top / Right
J1015		ADCD Analog Input	Top / Right
J30		External Reference Input	Bottom / Right
J29		External Clock Input	Bottom / Left
J4		External Clock Output	Bottom / Left
J24		External Trigger	Bottom / Left

4.2 Location on the board

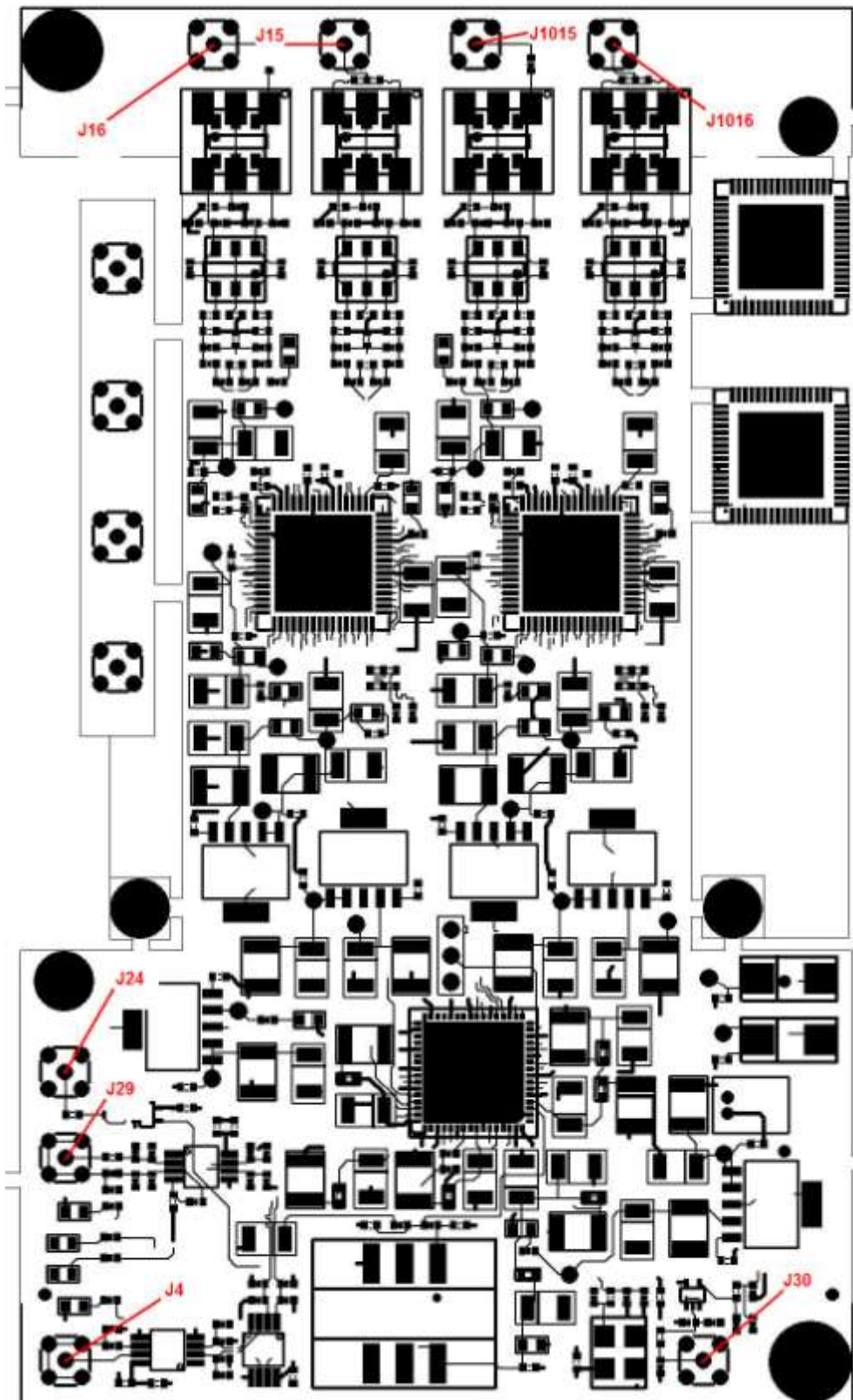

Figure 7 - Connectors

5 Physical Properties

Dimensions	63.5mm x 106.7mm x 18mm	
Weight	Tbc - 35 grams	
Supply Voltages		
Supply Current	+12V	N/A
	+5V	tbd
	+3.3V	tbd
	-5V	N/A
	-12V	N/A
MTBF		tbd

6 Safety

This module presents no hazard to the user when in normal use.

7 Ordering Information

SMT941 (Standard Product): ADC inputs are AC-coupled.

8 EMC

This module is designed to operate from within an enclosed host system, which is build to provide EMC shielding. Operation within the EU EMC guidelines is not guaranteed unless it is installed within an adequate host system.

This module is protected from damage by fast voltage transients originating from outside the host system which may be introduced through the output cables.

Short circuiting any output to ground does not cause the host PC system to lock up or reboot.