

US-D1 UAV Radar

Small. Easy Setup. Highly Customizable.



AINSTEIN™

Safety from numbers

ADDRESS:

2029 Becker Drive,
Lawrence, KS 66047 USA

EMAIL:

hi@ainstein.ai

PHONE:

785-856-0460

Overview

Ainstein's UAV Standard Radar Altimeter US-D1 is still the most compact radar altimeter for UAVs on the market today. So small it fits in the palm of your hands, you'll have greater flexibility with precious onboard real estate and payload.

The Standard Radar Altimeter US-D1 is designed to work in a multitude of environments from mountainous terrain to tree canopies, sand and water.

Do you fly over lakes or the ocean? It's normal for your UAV's components to get wet from choppy water, or simply from rain or fog. Worried about your expensive UAV electronics getting coated in mist from agricultural spraying, or covered in dust during takeoffs and landings?

Worry no more! Your drone's performance shouldn't suffer because of these real world operating conditions. We've designed Ainstein UAV Standard Radar Altimeter US-D1 to meet IP67 requirements – the highest protection rating for dust and water – making it impervious to these conditions and more.

The result? Better performance and a longer lifespan for your UAV.

Built for Tough Environments

WATER PROOF

Meets the highest Ingress Protection rating requirements IP67 for water

DUST PROOF

Meets the highest Ingress Protection rating requirements IP67 for dust



ROBUST AT HIGH SPEEDS/ TURBULENCE

Single board electronics design leaves no room for failure

COMPACT SIZE

Fits in the palm of your hands, Ainstein UAV Standard Radar Altimeter US-D1 is small and light enough even for your small camera drones

EASY TO USE

Plug-and-Play and CAN/UART firmware upgrade

Technical Data

Table 1: Specifications

Frequency Band	24 GHz
Bandwidth	190 MHz
Minimum Operating Altitude	0.5 meters
Maximum Operating Altitude	50 meters
Altitude Precision	6.0cm (< 1m), 4.0cm (> 1m)
Field of View	43 ° x 30 °
Interface	UART, CAN
Update Rate	UART: 82 Hz CAN : 86 Hz
Supply Voltage	5V~13V DC (5.5V recommended)
Power Consumption	2W(at 5 Volts DC input)
Operational Temperature Range	-20 °C ~ 65 °C*
Size	108 x 79 x 20 millimeters
Weight	110 grams
Environmental Conditions	IP67(with sealant)

- All specs above are measured under the environment of 35 °C temperature, standard atmospheric pressure and humidity, without any Electromagnetic Interference (EMI).
- Operational Temperature Range indicates radar works properly in this range. If operating temperature goes beyond this range, radar might not be accurate and can suffer mechanical damage.
- Radar unit can be shipped with either CAN or UART for it's output data protocol.
- * Operational Temperature Range is based off of the hardware's subcomponent specifications. Actual operational testing is still pending.



UART Data Protocol Specifications

- Baud Rate: 115200 b/s
- Data bit: 8
- Parity bit: N
- Stop bit: 1
- Voltage Level: 3.3V

A single data packet consists of six(6) bytes. Table 2 defines the packet structure.

Table 2: UART Data Packet Definition

From	US-D1 Altimeter	To	Receiver
Byte	Data	Note	
1	0xFE	Packet Head	
2	0x02	Version ID	
3	0x**	Altitude (Least Significant 8 Bits)	
4	0x**	Altitude (Most Significant 8 Bits)	
5	0x**	SNR	
6	0x**	Checksum (see formula below)	

Notes:

- ** refers to a variable bit containing dynamic data.
- This table ONLY describe the data format of standard firmware version. Please contact Ainstein AI for data formats of any customized firmware versions or customized firmware. requirement.
- Altitude: The altitude bytes can be combined (total 16 bits) to represent the altitude information in centimeters. The structure would be: 0x[MSB][LSB], where MSB and LSB are each two hexadecimal numbers (8 bits).
- Checksum: The Checksum Byte could be used in the following:
 - $checksum = (Version_ID + Altitude_H + Altitude_L + SNR) \& 0xFF$
 - If checksum = 1, check passed
 - if checksum = 0, check failed

CAN Data Protocol Specifications

- Baud Rate: 1 Mb/s
- Frame ID: customized (Standard Frame, Extended Frame)
- Standard: CAN Protocol 2.0 section A and B, ISO 11898-1:2015,-4

A single data packet uses four bytes of either, a Standard or Extended CAN frame. The type of CAN frame used and CAN ID of the device can be customized. The CAN frame is defined in table 3.

Table 3: CAN Frame Data Packet Definition

From	US-D1 Altimeter	To	Receiver
Byte	Data	Note	
StdID	0x***	Standard ID frame	
EtdID	0x*****	Extended ID frame (Default 0x00090002)	
1	0x**	Altitude (Most Significant 8 Bits)	
2	0x**	Altitude (Least Significant 8 Bits)	
3	0x**	SNR(Most Significant 8 Bits)	
4	0x**	SNR(Least Significant 8 Bits)	
5	0x00	(Reserved)	
6	0x00	(Reserved)	
7	0x00	(Reserved)	
8	0x00	(Reserved)	

Mechanical Drawing

Figure 1: Dimensions of US-D1 (Units: mm)

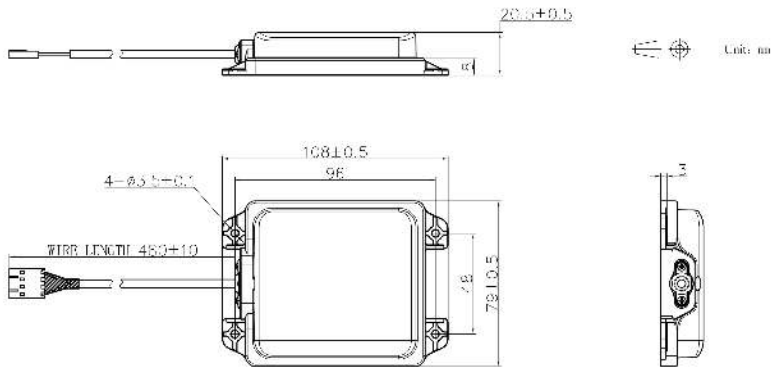
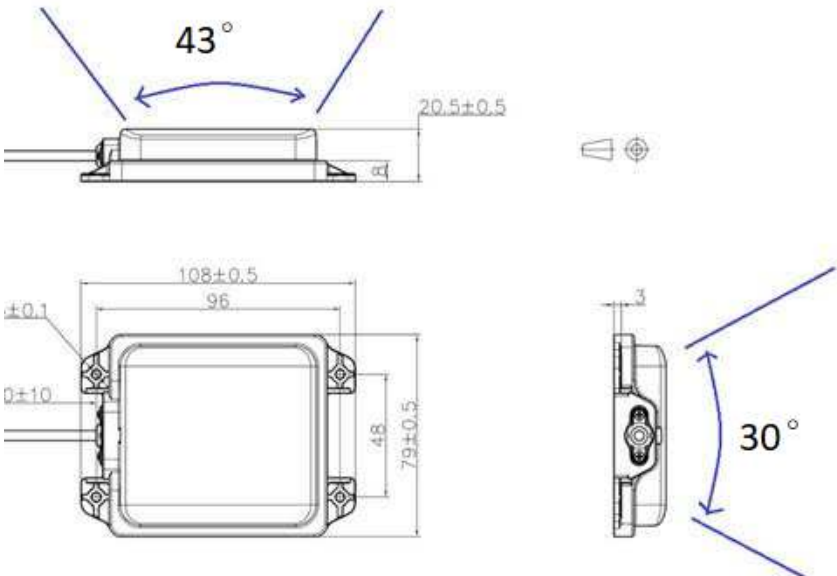

Figure 2: Field of View Orientation



Hardware Interface

Table 4: Data Packet Definition

Wire Color	UART	CAN
Black	Ground	Ground
White	RX(Radar)	CAN_LOW
Green	TX(Radar)	CAN_HI
Red	Voltage(5~13V)	Voltage(5~13V)

Figure 3: US-D1 Cabling Interface

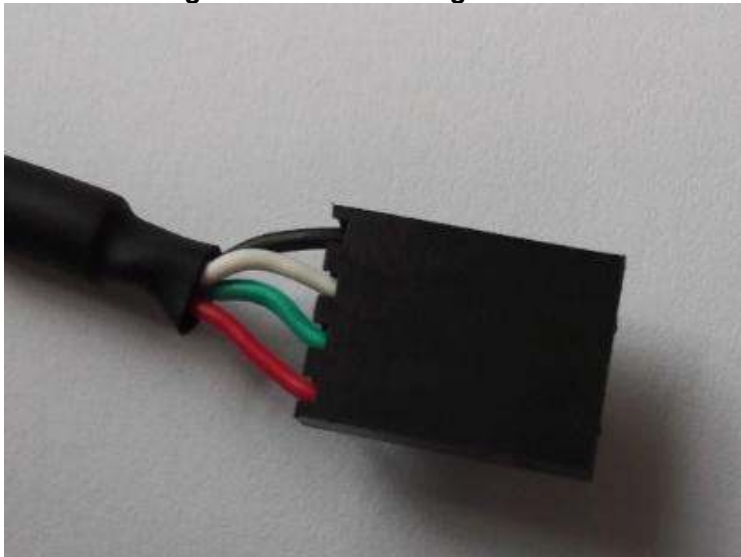

Installation Instructions

Mounting Requirements:

Radar face should be perpendicular to the target to be measured

Keep radar face clean, and do not cover it.

Keep any unexpected objects out of radar's FoV (Field of View), otherwise it might interfere radar's signal

No specific requirement for mounting orientation

Figure 3: Proper Mounting Example

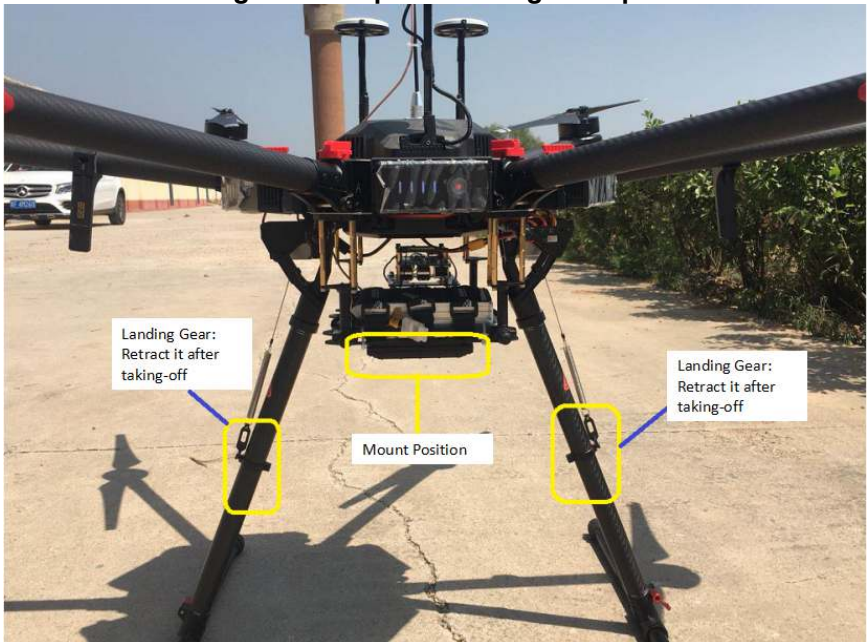

Ensure altimeter will not be obstructed by mechanical landing gear!

Known Issues

Table 5 lists the known issues that will be addressed in future revisions.

Table 5: US-D1 Known Issues

Issue ID	Description	Notes
1	If US-D1 is used outside of its Maximum Operational Altitude (Table 1). Inconsistent small readings will be output (See Figure 4 below).	<ul style="list-style-type: none">• For full confidence, only consider US-D1's data when used within its operating range
2	Altitude data from US-D1 may have various step-size, since some post-processing algorithm is implemented after radar processing, e.g. averaging,	<ul style="list-style-type: none">• No action needed
3	Altitude data from US-D1 may give unexpected or incorrect measurements under operation in an indoor environment. Multipath reflections of the sensor's radio waves are complicated in enclosed environments and may therefore introduce errors in the radar's	<ul style="list-style-type: none">• DO NOT rely on US-D1 in an indoor, tightly enclosed environment

4	The CAN Bus that CAN HI and CAN LOW are connected to must be between -2V and 5V power supply or it is at risk of burning the hardware.	<ul style="list-style-type: none">• Under no circumstances will Ainstein be held responsible or liable in any way for any claims, damages, losses, expenses, costs or liabilities whatsoever from your use of the US-D1 outside the range a -2V and 5V power supply
---	--	---

Figure 5: US-D1 Altitude Drop-off Example

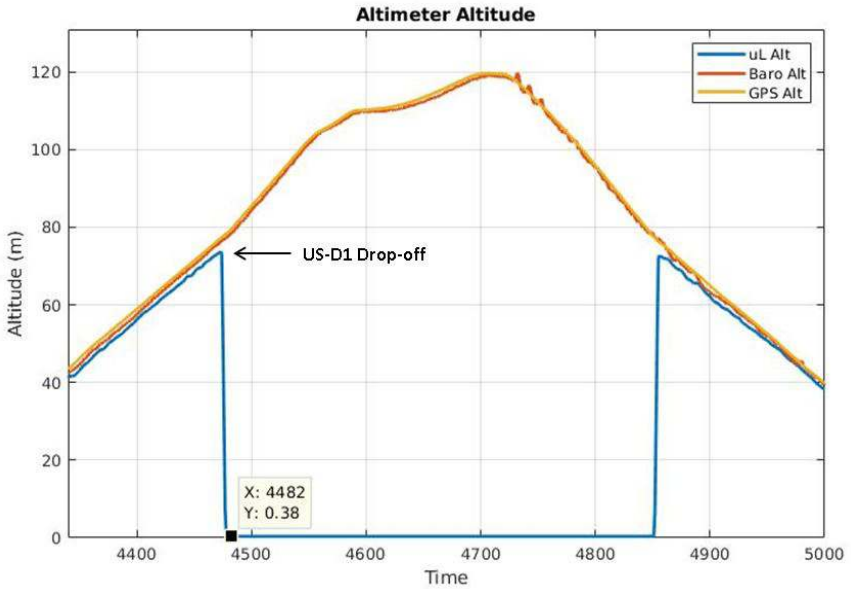

Hardware & Firmware Version

Firmware	V1.52
Bootloader	V1.07
Hardware	V1.1.0

About Einstein

Our mission is to enable safer driving, flying, working and living through radar-based technology. We are in the business of improving safety and protecting valuable assets through innovations in radar technology.

Ainstein makes radar systems smarter, more affordable and easier to deploy. We offer complete solutions for autonomous drones, advanced driver-assistance systems (ADAS), autonomous vehicles and industrial sensing – incorporating a combination of millimeter wave (mmWave) radar, sensor fusion and artificial intelligence (AI).

For years, cost, weight and performance constraints have hindered the wider adoption of radar. Ainstein makes radar systems accessible to everyone by overcoming these constraints. One recent innovation: we've developed the world's first UAV collision avoidance radar with 4D detection.

Radar systems and sensor data processing intelligence are keys to our autonomous future. We offer deep scientific, mathematical and engineering expertise along with a full spectrum portfolio (24GHz, 60GHz, 76-81GHz) of hardware and software to support our customers in developing highly customized solutions with unmatched precision in unpredictable environments.

Our core team has more than a combined 100 years of experience in radar research and development with deep knowledge gained through projects funded by NASA, the U.S. National Science Foundation (NSF), the European Space Agency and others.

Other radar companies are at least two to three years behind Ainstein. Startups have been slow to market and are unable to produce at scale, while established companies are slow to adopt the newest technological innovations.

Ainstein products can be fully customized to specific application requirements, have unmatched precision in ALL weather conditions and surface types, and are a fraction of the price of competitive products.

Visit our website (www.ainstein.ai) for more information, or get in touch with Andrew Boushie, Vice President for Strategy and Partnerships, at andrew.boushie@ainstein.ai to arrange a phone call.