



SERIES MMCX MICRO MINIATURE CONNECTORS

DESCRIPTION

HUBER+SUHNER® MMCX connectors are intended for use in applications where the smallest dimensions have to be achieved. These connectors can be used in applications from DC to 6 GHz.

The reliable "snap-on" coupling mechanism ensures that the electrical parameters are consistently reproduced. Due to its non-slotted outer contact, the MMCX series provides a low RF-leakage.

In addition, HUBER+SUHNER SMT MMCX connectors fully meet today's SMT (Surface Mount Technology) requirements with superior design, material selection and packaging.

The HUBER+SUHNER SMT connectors are suitable to all reflow-soldered SMT-PCBs where impedance matching or screened signal transmission is necessary

CONTENTS

PAGE

Description	51
Interface dimensions	51
Interface dimensions in mm / inches	51
Technical data	52
Cable connectors	54
Receptacles with solder end	58
PCB connectors	58
MMCX "cube"-connectors	61
Packaging MMCX "cube"-connectors	62
Application notes MMCX "cube"-connectors	63
Packaging for MMCX edge mount	66
Application notes for MMCX edge mount	66

MMCX

INTERFACE DIMENSIONS

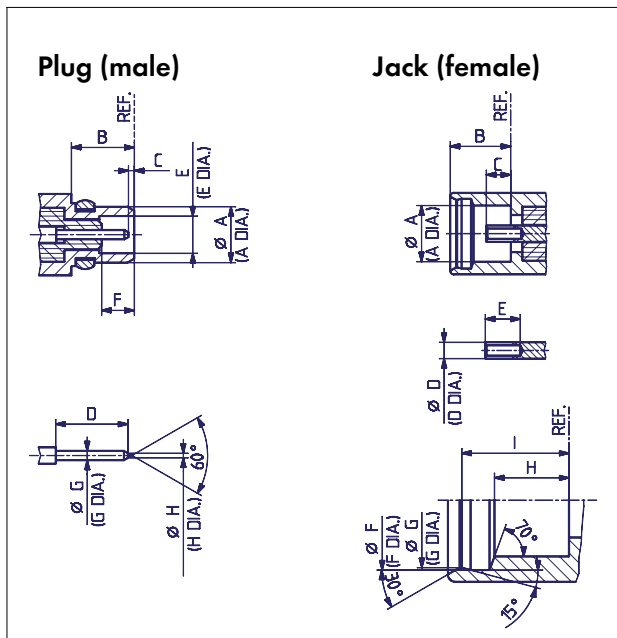

INTERFACE DIMENSIONS (MM / INCHES)

	Plug		Jack	
	min.	max.	min.	max.
A	–	2.40/.094	2.41/.095	–
B	2.70/.106	–	–	2.65/.104
C	0.00/.000	0.25/.010	0.90/.035	1.20/.047
D	1.23/.048	–	0.70/.028 nom.	
E	1.58/.062	1.62/.064	1.40/.055	–
F	1.23/.048	–	3.00/.118	3.04/.120
G*	0.38/.015	0.42/.017	2.88/.113	2.92/.115
H	–	0.20/.008	1.57/.062	1.63/.064

*	Jack		
G	2.88/.113	2.90/.114	2.92/.115
I	2.34/.092	2.30/.091	2.26/.089

Note: I is related to G

IP rating (interface, mated) IP50

TECHNICAL DATA

ELECTRICAL DATA	CECC 22000	TEST REQUIREMENTS
Impedance		50 Ω
Frequency range		DC ... 6 GHz
Dielectric withstanding voltage (at sea level)	4.4.5	500 V rms, 50 Hz
Working voltage (at sea level)		≤ 170 V rms, 50 Hz
Insulation resistance	4.4.4	≥ 10 ³ MΩ / ≥ 500 MΩ ¹⁾
Contact resistance		
- centre contact	4.4.2	≤ 5.0 mΩ / ≤ 10 mΩ ¹⁾
- outer contact	4.4.3	≤ 2.5 mΩ / ≤ 5 mΩ ¹⁾
VSWR (mated pair)		(typical values)
- up to 4 GHz	4.4.1	≤ 1.15
- 4 up to 6 GHz		≤ 1.40
		for cable connectors, see table below
RF leakage (measured at 1 GHz)		
- connectors for flexible cables	4.4.8	≥ 60 dB
- connectors for semi-rigid cables		≥ 70 dB

1) valid for MMCX "Cube"-connectors only.

TYPICAL VSWR	FREQUENCY RANGE			CABLE GROUP
	1 GHZ	2.5 GHZ	6 GHZ	
straight connectors	1.03	1.08	1.12	Y3, Y11
	1.04	1.08	1.12	U1
right angle connectors	1.03	1.08	1.13	Y3, Y11
	1.07	1.12	1.25	U1

Other connectors and cables on request

MECHANICAL DATA	CECC 22000	REQUIREMENTS
Engagement force	4.5.4	≤ 15 N / 3.4 lbs
Disengagement force	4.5.4	6 N ... 15 N / 1.4 lbs ... 3.4 lbs
Contact captivation	4.5.2	≥ 10 N / 2.3 lbs
Cable retention force ²⁾	4.5.5	see pages 28 - 34
Durability (matings)	4.7.1	≥ 500

2) value considers maximum load of the cables without irreversible variations of specifications.

ENVIRONMENTAL DATA	CECC 22000 TEST CONDITIONS	EQUIVALENT MIL TEST CONDITIONS
Temperature range		- 55° C ... + 155° C / - 67 °F ... + 311 °F
Climatic category	4.6.5 → 55 / 155 / 21	
Thermal shock	4.6.7 → IEC 68-2-14 Na	MIL-STD-202, Method 107, Condition F
Moisture resistance	4.6.6 → IEC 68-2-3 Ca	MIL-STD-202, Method 106
Corrosion	4.6.10 → IEC 68-2-11 Ka	Saltspray test acc. to MIL-STD-202, Method 101, Condition B
Vibration	4.6.3 → IEC 68-2-6 Fc	MIL-STD-202, Method 204, Condition C

ENVIRONMENTAL DATA FOR "CUBE"-CONNECTORS ONLY	CECC 22000 TEST CONDITIONS	EQUIVALENT MIL TEST CONDITIONS
Temperature range		- 40°C ... + 90°C / - 40 °F ... + 194 °F
Climatic category	4.6.5 → 40 / 90 / 21	
Thermal shock	4.6.7	MIL-STD-202, Method 107, - 40°C/ 40 °F and + 90°C/ + 194 °F, 30 min. each
Moisture resistance	4.6.6	MIL-STD-202, Method 103, Condition B
Vibration	4.6.3	3 cycles in 3 opposite directions 10-150 Hz, 10-60 Hz: 0.75 mm/.030 in., 60-150 Hz: 10 G
Mechanical shock	4.6.4	MIL-STD-202, Method 213, Condition B

MATERIAL DATA

CONNECTOR PARTS	MATERIAL	PLATING
Centre contact	copper-beryllium alloy, bronze	SUCOPRO / gold
Body	brass	SUCOPRO / gold
Crimp ferrules	brass	SUCOPRO / gold
Insulators	PTFE or PFA	

MATERIAL DATA FOR "CUBE"-CONNECTORS ONLY

CONNECTOR PARTS	MATERIAL	PLATING
Leads Contact sockets	bronze	gold
Body	LCP (liquid crystal polymer), brass	gold
Outer contact	brass	gold
Insulators	LCP (liquid crystal polymer), PTFE or PFA	

PROCESSING DATA

FOR "Cube"-CONNECTORS ONLY	TEST STANDARD	REQUIREMENT
Lead free reflow process	IPC/JEDECJ-STD-020C	recommended
Adherent to the print - shearing - pulling (vertical to PCB)		25 N/5.6 lbs 50 N/11.2 lbs

Some connectors may have a specification that differs from the above mentioned data.

The products are designed and guaranteed to pass the above mentioned test procedures. Any additional or different requirement arising from specific applications or environmental conditions which is not covered by these test procedures is subject to request.

CABLE CONNECTORS

Straight cable plugs (male)

- > for semi-rigid cables
- > cable entry soldered
- > centre contact crimped

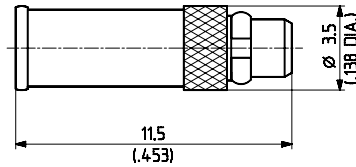

HUBER+SUHNER type	Item no.	Cable group (example)	Packaging	Assembly instruction	Crimp insert
11_MM CX-50-1-3/111_OE	22648893	Y2 (EZ 47)	single	9078	1
11_MM CX-50-2-1/111_OE	22645297	Y3, Y11 (EZ 86)	single	9170	1
11_MM CX-50-2-1/111_OH	22649039	Y3, Y11 (EZ 86)	bulk 100 pcs.	9170	1

- > for flexible cables
- > HUBER+SUHNER® full crimp

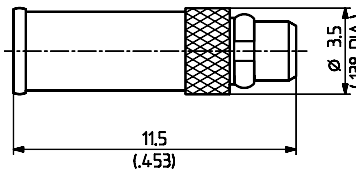

HUBER+SUHNER type	Item no.	Cable group (example)	Packaging	Assembly instruction	Crimp insert
11_MM CX-50-1-1/111_OE	22645298	U1 (EF 178)	single	9169	1 / 2.67
11_MM CX-50-1-1/111_OH	22651666	U1 (EF 178)	bulk 100 pcs.	9169	1 / 2.67
11_MM CX-50-1-2/111_OE	22645296	U0 (K 01152-07)	single	9169	1 / 2.67
11_MM CX-50-1-2/111_OH	84027753	U0 (K 01152-07)	bulk 100 pcs.	9169	1 / 2.67

- > for flexible cables
- > HUBER+SUHNER® full crimp

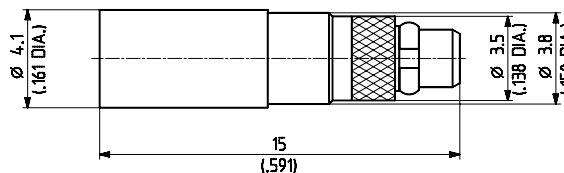

HUBER+SUHNER type	Item no.	Cable group (example)	Packaging	Assembly instruction	Crimp insert
11_MM CX-50-2-3/111_OE	22649899	U2 (EF 316)	single	9110	1 A
11_MM CX-50-2-3/111_OH	23000258	U2 (EF 316)	bulk 100 pcs.	9110	1 A
11_MM CX-50-2-4/111_OE	22649901	U4 (EF 316 D)	single	9110	1 A

Right angle cable plugs (male)

- > for semi-rigid cables
- > cable entry soldered
- > centre contact soldered

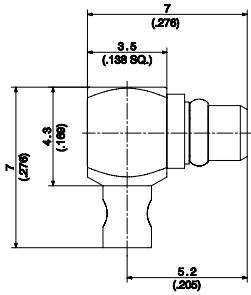

Fig. 1

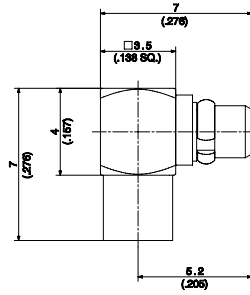

Fig. 2



MMCX

HUBER+SUHNER type	Item no.	Cable group (example)	Packaging	Assembly instruction	Fig.
16_MMCX-50-1-12/111_OE	84030531	Y2 (EZ 47)	single	0000180777	1
16_MMCX-50-1-12/111_OH	21000178	Y2 (EZ 47)	bulk 100 pcs.	0000180777	1
16_MMCX-50-2-13/111_OE	84032569	Y3, Y11 (EZ 86)	single	0000214734	2
16_MMCX-50-2-13/111_OH	84007944	Y3, Y11 (EZ 86)	bulk 100 pcs.	0000214734	2

- > for flexible cables
- > cable entry crimp
- > centre contact soldered

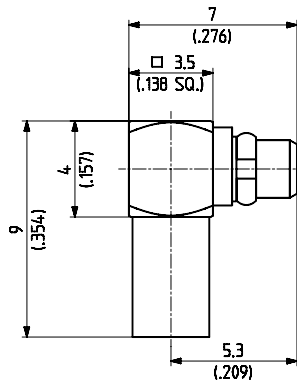

HUBER+SUHNER type	Item no.	Cable group (example)	Packaging	Assembly instruction	Crimp insert
16_MMCX-50-1-1/111_OE	22645955	U1 (EF 178)	single	9175	2.67
16_MMCX-50-1-1/111_OH	22648762	U1 (EF 178)	bulk 100 pcs.	9175	2.67

- > for flexible cables
- > cable entry crimp
- > centre contact soldered

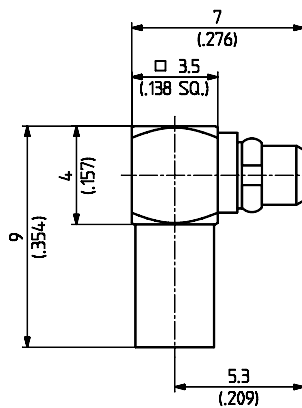

HUBER+SUHNER type	Item no.	Cable group (example)	Packaging	Assembly instruction	Crimp insert
16_MMCX-50-1-2/111_OE	22645956	U0 (K 01152-07)	single	9175	2.67
16_MMCX-50-1-2/111_OH	22649009	U0 (K 01152-07)	bulk 100 pcs.	9175	2.67

- > for flexible cables
- > cable entry crimp
- > centre contact soldered

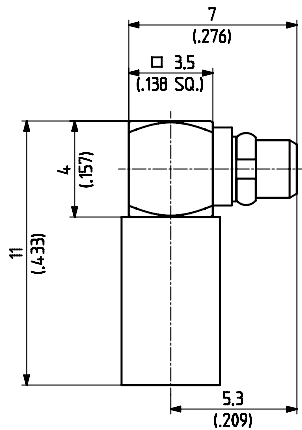

HUBER+SUHNER type	Item no.	Cable group (example)	Packaging	Assembly instruction	Crimp insert
16_MMCX-50-1-7/111_OE	22649900	Cable: K 01252 D	single	9128	A
16_MMCX-50-1-7/111_OH	23008430	Cable: K 01252 D	bulk 100 pcs.	9128	A
16_MMCX-50-2-2/111_OE	22649374	U4 (EF 316 D)	single	9128	A
16_MMCX-50-2-2/111_OH	22651401	U4 (EF 316 D)	bulk 100 pcs.	9128	A
16_MMCX-50-2-4/111_OE	22649433	U2 (EF 316)	single	9128	A
16_MMCX-50-2-4/111_OH	22649635	U2 (EF 316)	bulk 100 pcs.	9128	A

Straight cable jacks (female)

- > for semi-rigid cables
- > cable entry soldered
- > centre contact crimped

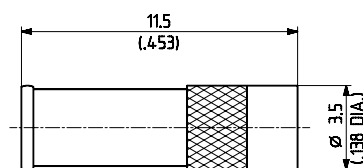

HUBER+SUHNER type	Item no.	Cable group (example)	Packaging	Assembly instruction	Crimp insert
21_MMCX-50-2-1/111_OE	22645290	Y3, Y11 (EZ 86)	single	9170	1

- > for flexible cables
- > HUBER+SUHNER® full crimp

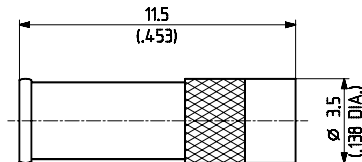

HUBER+SUHNER type	Item no.	Cable group (example)	Packaging	Assembly instruction	Crimp insert
21_MMCX-50-1-1/111_OE	22645288	U1 (EF 178)	single	9169	1 / 2.67
21_MMCX-50-1-2/111_OE	22645289	U0 (K 01152-07)	single	9169	1 / 2.67

Straight bulkhead cable jacks (female)

- > for semi-rigid cables
- > cable entry soldered
- > centre contact crimped
- > front mounting

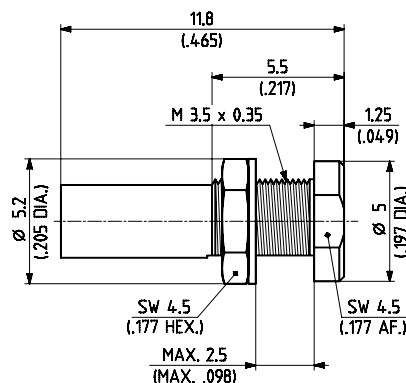

HUBER+SUHNER type	Item no.	Cable group (example)	Packaging	Assembly instruction/ Mounting hole	Crimp insert
24_MMCX-50-2-1/111_OE	22645954	Y3, Y11 (EZ 86)	single	9170 / ML 68	1

- > for flexible cables
- > HUBER+SUHNER® full crimp
- > front mounting

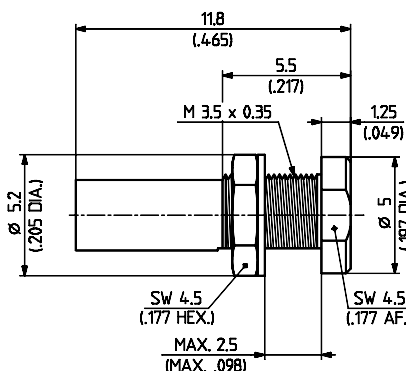

HUBER+SUHNER type	Item no.	Cable group (example)	Packaging	Assembly instruction/ Mounting hole	Crimp insert
24_MMCX-50-1-1/111_OE	22645952	U1 (EF 178)	single	9169 / ML 68	1 / 2.67
24_MMCX-50-1-1/111_OH	23000416	U1 (EF 178)	bulk 100 pcs.	9169 / ML 68	1 / 2.67

RECEPTACLES WITH SOLDER END

Receptacles, jacks (female)

> bulkhead mounted

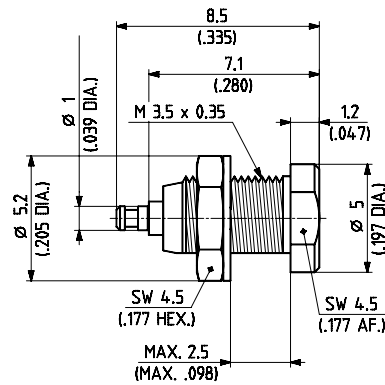

HUBER+SUHNER type	Item no.	Packaging	Mounting hole	Notes
22_MMCX-50-0-1/111_OE	22645951	single	ML 68	
22_MMCX-50-0-1/111_OH	22660126	bulk 100 pcs.	ML 68	

> bulkhead mounted

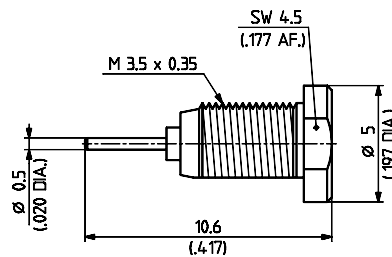

HUBER+SUHNER type	Item no.	Packaging	Mounting hole	Notes
22_MMCX-50-0-4/111_OH	22660282	bulk 100 pcs.	M 3.5 × 0.35	

PCB CONNECTORS

Straight PCB plugs (male)

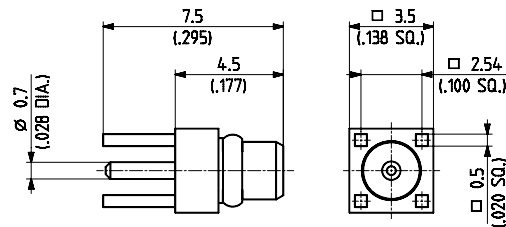

HUBER+SUHNER type	Item no.	Packaging	Mounting hole	Notes
81_MMCX-50-0-1/111_OE	22646298	single	ML 44	without stand-off

Straight PCB jacks (female)

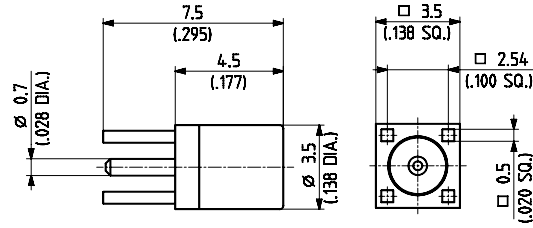

HUBER+SUHNER type	Item no.	Packaging	Mounting hole	Notes
82_MMCX-50-0-1/111_NE	22645958	single	ML 44	without stand-off
82_MMCX-50-0-1/111_NH	22648469	bulk 100 pcs.	ML 44	without stand-off

Jacks for horizontal applications

> edge mount

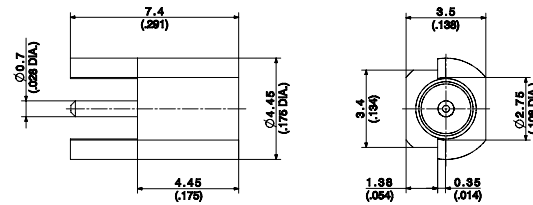

HUBER+SUHNER type	Item no.	Packaging	PCB Layout	Notes
82_MMCX-S50-0-2/111_KE	22648789	single	see application notes on page 66	
82_MMCX-S50-0-2/111_KH	22649680	bulk 100 pcs.	see application notes on page 66	
82_MMCX-S50-0-2/111_KG	22649679	tape and reel	see application notes on page 66	blister tape containing 750 pcs.
82_MMCX-S50-0-2/111_KL-1	23041776	tape and reel	see application notes on page 66	blister tape containing 1500 pcs.

Straight PCB jacks (female)

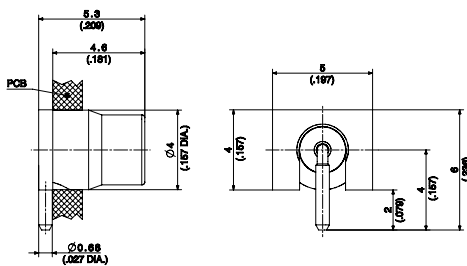

Fig. 1

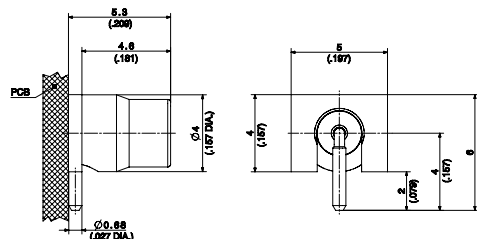
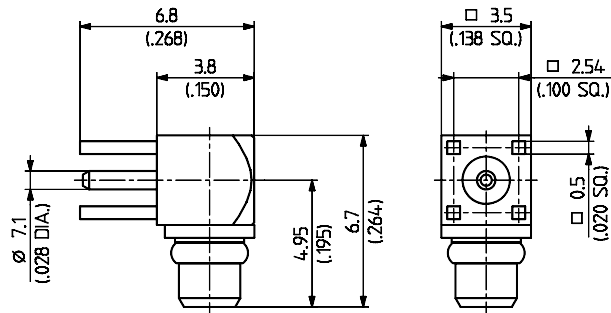

Fig. 2



HUBER+SUHNER type	Item no.	Packaging	Mounting hole	Notes	Fig.
82_MMCX-50-0-8/111_OE	22652153	single	ML 167	throughhole mount	1
82_MMCX-50-0-8/111_OM	22660270	tape and reel	ML 167	throughhole mount	1
82_MMCX-50-0-18/111_OM	23023564	tape and reel	ML 130	surface mount technology	2

Right angle PCB plugs (male)



HUBER+SUHNER type	Item no.	Packaging	Mounting hole	Notes
84_MMCX-50-0-1/111_OH	22658819	bulk 100 pcs.	ML 44	without stand-off

Right angle PCB jacks (female)

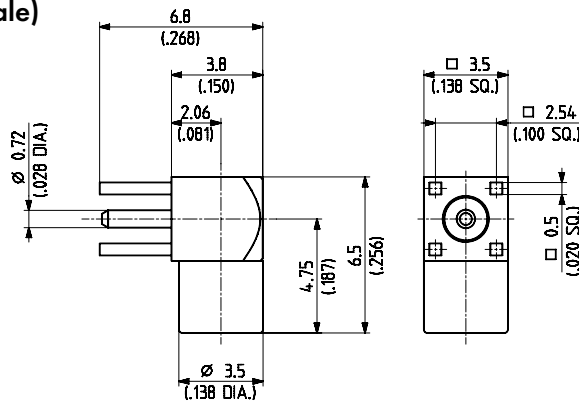

HUBER+SUHNER type	Item no.	Packaging	Mounting hole	Notes
85_MMCX-50-0-1/111_OE	22645968	single	ML 44	without stand-off
85_MMCX-50-0-1/111_OH	22646636	bulk 100 pcs.	ML 44	without stand-off

MMCX "CUBE"-CONNECTORS

Jack for straight (vertical) applications

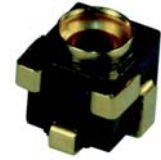
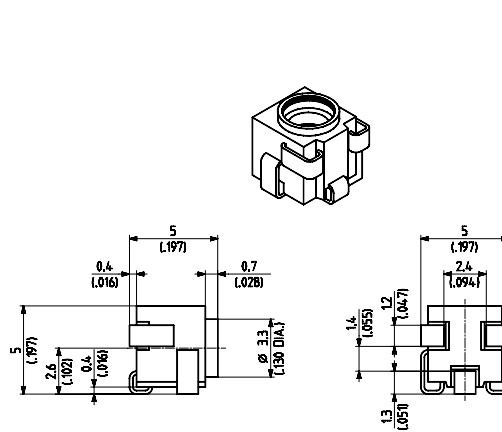

HUBER+SUHNER type	Item no.	Packaging	PCB Layout	Notes
82_MMCX-S50-0-55/119_OM	84021645	tape and reel	see application notes on page 63	blister tape containing 1500 pcs.

Jack for right angle (horizontal) applications



HUBER+SUHNER type	Item no.	Packaging	PCB Layout	Notes
85_MMCX-S50-0-55/119_OM	84021646	tape and reel	see application notes on page 63	blister tape containing 1500 pcs.

Combination jack

for straight (vertical) or right angle (horizontal) applications

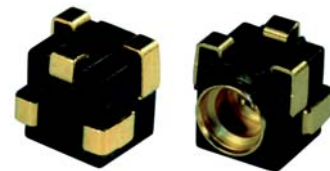

HUBER+SUHNER type	Item no.	Packaging	PCB Layout	Notes
90_MMCX-S50-0-55/119_OE	84021577	single	see application notes on page 63	
90_MMCX-S50-0-55/119_OH	84021269	bulk 100 pcs.	see application notes on page 63	

PACKAGING FOR MMCX "Cube"-CONNECTORS

Blister tape supply in accordance with IEC 286-3/EIA-481

For automated placement the connectors can be supplied on industry standard tape-and-reel. Depending on the application, they are packaged uniformly either for vertical or horizontal mounting.

Bulk supply in bags of one single or 100 pcs. (90_MMCX-S50-0-55)

This delivery form supports vertical or horizontal applications of the SMT MMCX connector. It is suitable for manual or automated tube fed pick-and-place assembly.

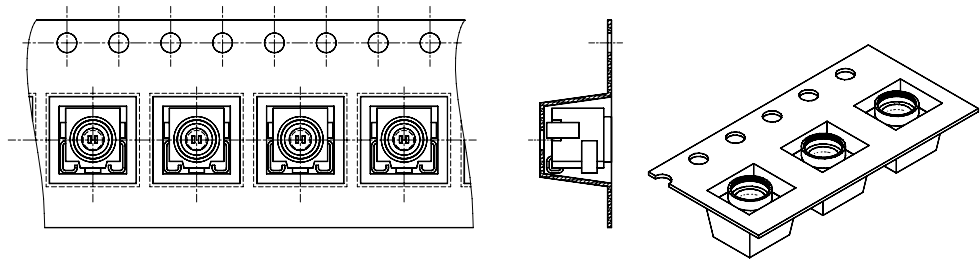

1. straight (vertical) application (82_MMCX-S50-0-55)

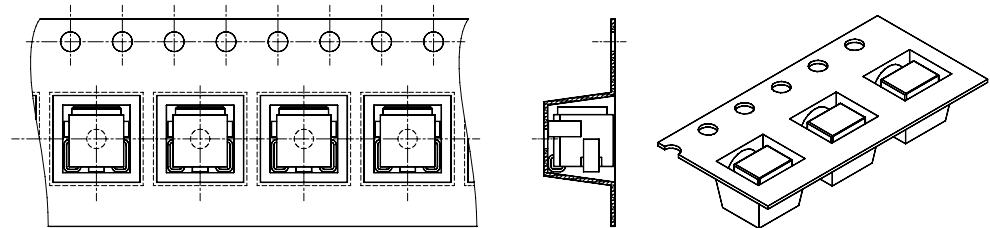

2. right angle (horizontal) application (85_MMCX-S50-0-55)

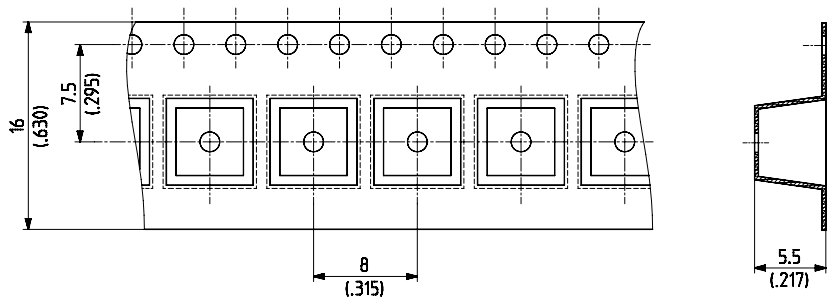

Dimensions of blister carrier tape

The 16 mm/.63 inches blister tape is delivered on reels of 330 mm/13 inches diameter and in tough cardboard boxes.

APPLICATION NOTES FOR MMCX "Cube"-CONNECTORS

Dimensions of mated pair and clearance for mating

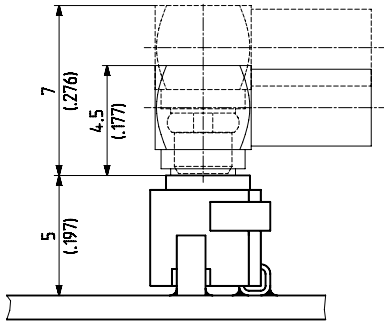

Vertical mounting together with a right angle cable connector (can be rotated by 360°)

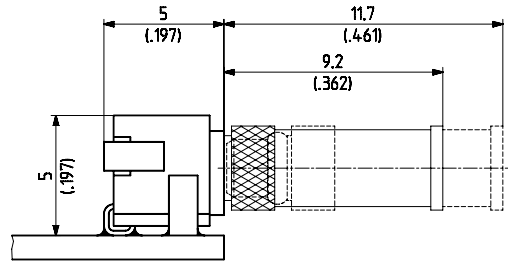

Horizontal mounting together with a straight cable connector

Appropriate operation

Surface-mounted electronic components exhibit a lower adherence force to the PCB than through-hole components.

The solder joints act as a mechanical fixation to the board and also function as the electrical contact.

Therefore the following has to be considered:

- Avoid forces from the cable of the mating connector to the surface mount connector.
Fix the cable sufficiently and in several places.
- Apply only axial forces during the mating and de-mating of the connector parts.

Non-axial forces – such as improper pulling at the cable entry or the cable portion of right angle mating connector – may cause excessive torque forces, which could result in damage to the solder joints.

Recommendation:

Application of the assembly tools 74_Z-0-225 or 74_Z-0-272 when disengaging right angle connectors. The tool 74_Z-0-272 can simultaneously be used as a mating support for straight connectors.

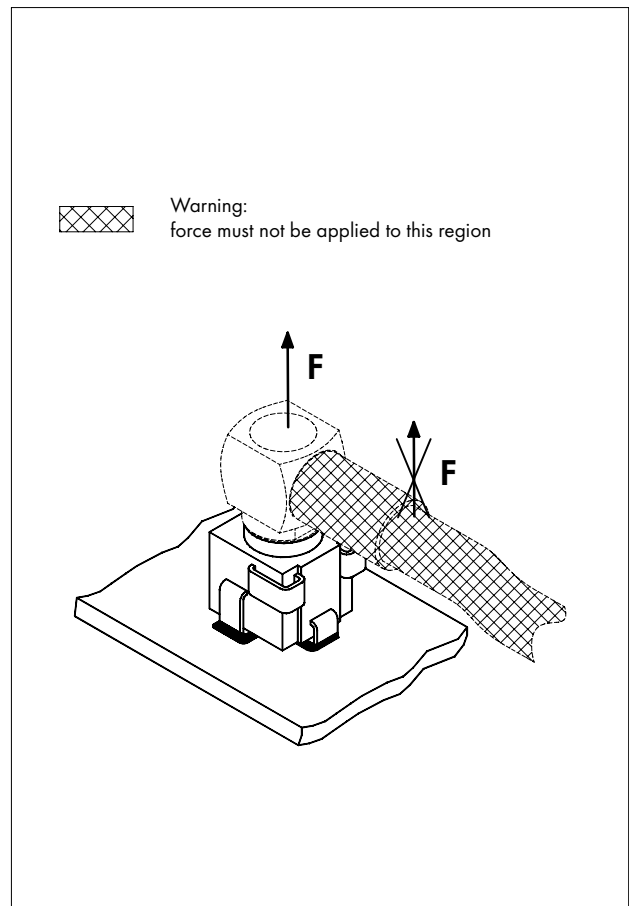

Recommended mounting pattern for MMCX "Cube"-connectors

MATERIAL FR 4 ($\epsilon_r = 4.6$)

- pattern
- land (free of solder mask)

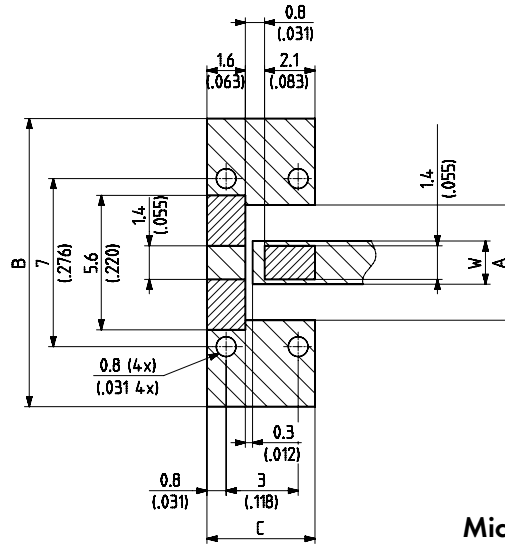

Microstrip line

PCB thickness	W	A	B	C
1.0 mm / .039 in.	1.8 mm / .071 in.	2.4 mm / .094 in.	12 mm / .472 in.	4.5 mm / .177 in.
1.6 mm / .063 in.	2.8 mm / .110 in.	4.8 mm / .189 in.	16 mm / .630 in.	5.0 mm / .197 in.

MATERIAL FR 4 ($\epsilon_r = 4.6$)

- pattern
- land (free of solder mask)

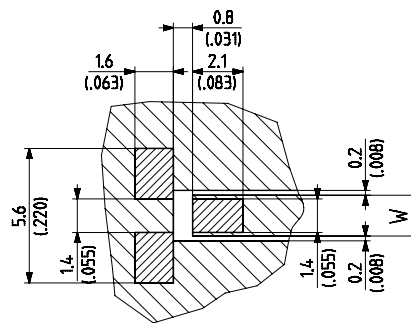

Coplanar line

PCB thickness	W
0.8 mm / .031 in.	1.85 mm / .037 in.
1.0 mm / .039 in.	1.70 mm / .067 in.
1.2 mm / .047 in.	1.60 mm / .063 in.
1.6 mm / .063 in.	1.50 mm / .059 in.

Data valid for PCB material FR 4 ($\epsilon_r = 4.6$)

Automated pick-and-place for MMCX “Cube”-connectors

The MMCX “Cube” connectors can be processed on all state-of-the-art pick-and-place machines.

Application hints:

- Position of the connectors in the carrier tape

For the uniform orientation of the connectors refer to the figures in section “Packaging” (see page 62).

- Connector pick up by suction tip
1. Vertical mounting (82_MMCXS50-0-55)

You have the choice between the contact of the suction tip on the outer edge of the outer conductor sleeve (convenient circular or square standard tip) or the insertion of a special tip into the connector interface.

When using an insertion tip consider that the outer conductor sleeve is only centered along one axis. A chuck alignment is possible only along this axis, which however is fully sufficient.

2. Horizontal mounting (85_MMCXS50-0-55)

The suction tip meets an even surface and can be a suitable standard one:

- Vision system alignment inspection
The optical alignment inspection of the MMCX “cube” connector is supported by its asymmetrical contour in vertical as well as horizontal applications.
- Placement

For placing the connectors, the special arrangement of the leads must be considered. When applying a suction tip, the eccentricity of the outer conductor sleeve has to be taken into account.

Soldering

MMCX “Cube” connectors are compatible with reflow soldering methods.

Infrared soldering (IR, IC - max. 260°C/500 °F, 10s) is recommended.

Lead free solder pastes (96.5% tin, 3.5% silver) can be used with a thickness of 0.20 mm/.008 inches to 0.25 mm/.010 inches if stencilled or screened in accordance with our recommended mounting pattern. The stand-off of 0.4 mm/.016 inches enables an easy visual inspection of the soldered joint.

Cleaning

The stand-off also allows effective cleaning after soldering, if necessary. It is especially advantageous when applying aqueous solutions.

Because of the material used, MMCX “cube” connectors withstand solvents such as alcohols, halogenated hydrocarbons and azeotropic solutions, as well as water mixed with alkaline saponifiers.

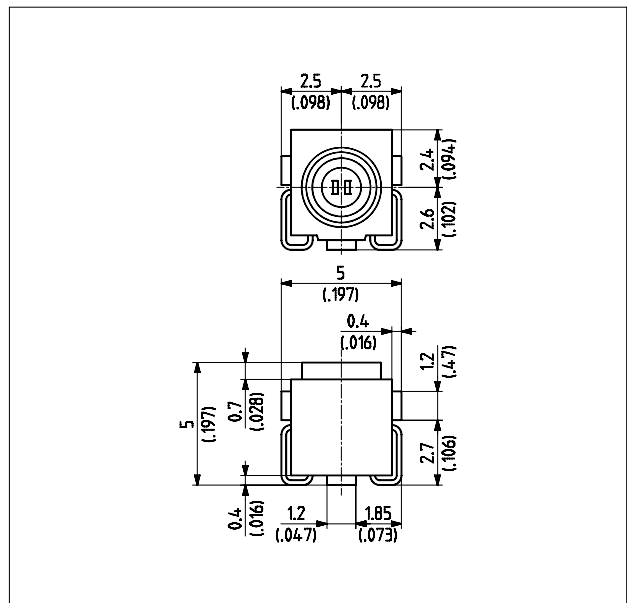
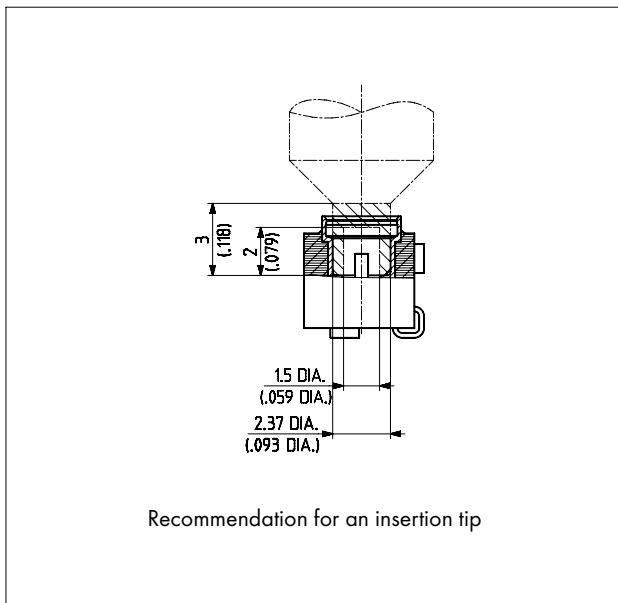

PACKAGING FOR MMCX EDGE MOUNT CONNECTORS

Blister tape supply in accordance with IEC 286-2/EIA-481

For automated placement the connectors can be supplied on industry standard type-and-reel.

Bulk supply in bags of 100 pcs.

This delivery form is suitable for manual or automated tube fed pick-and-place assembly.

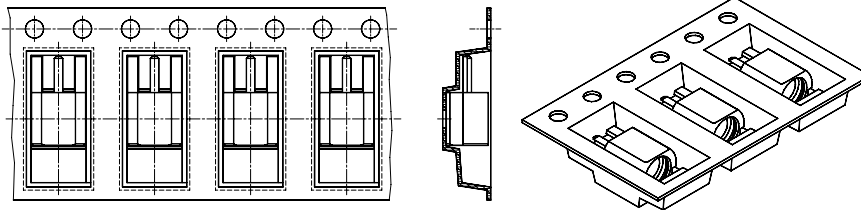

straight (horizontal) application

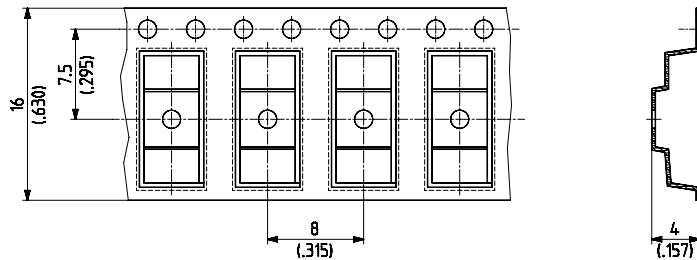

dimensions of blister carrier tape

The 16 mm/.63 inches blister tape is delivered on reels of 330 mm/13 inches diameter, in a tough cardboard box.

APPLICATION NOTES FOR MMCX EDGE MOUNT

Dimensions of mated pair and clearance for mating

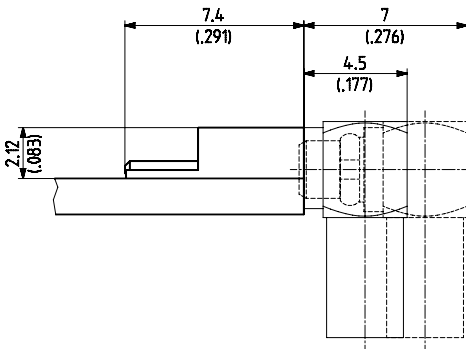

Horizontal mounting together with a right angle cable connector

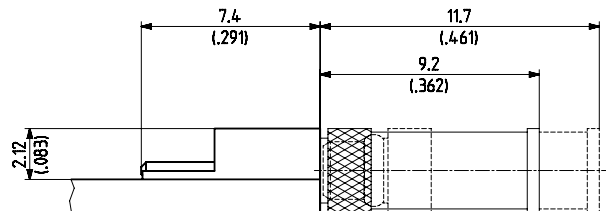

Horizontal mounting together with a straight cable connector

Appropriate operation for MMCX edge mount

For appropriate operation the following has to be considered:

- Avoid forces from the cable of the mating connector to the surface mount connector.
Fix the cable sufficiently and in several places.
- Apply only axial forces during the mating and demating of the connector parts.

Non-axial forces – such as improper pulling at the cable entry or the cable portion of a right angle mating connector – may cause excessive torque forces, which could result in damage to the solder joints.

For further information about soldering or cleaning, please see page 65.

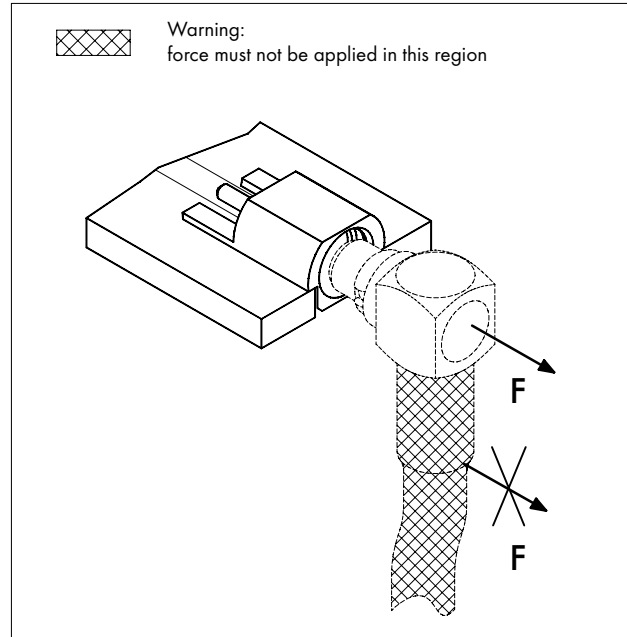

Recommended mounting pattern for MMCX edge mount

Material FR 4 ($\epsilon_r = 4.6$)

pattern

land (free of solder mask)

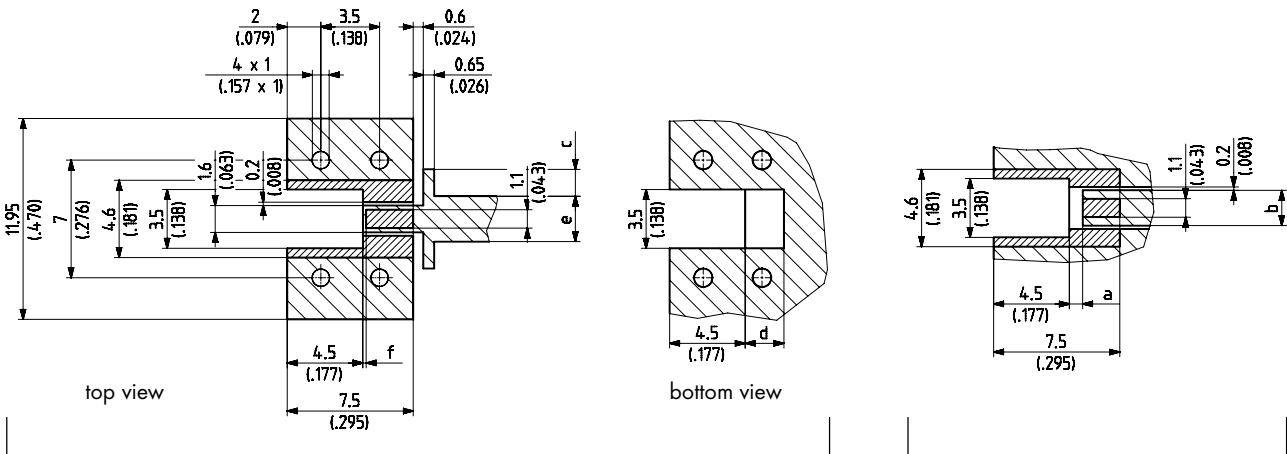

Microstrip line

Coplanar line

PCB thickness	a	b	c	d	e	f
0.8 mm / .031 in.	1.6 / .063	1.90 / .075		1.1 / .043	1.4 / .055	1.0 / .039
1.0 mm / .039 in.	1.4 / .055	1.75 / .069	0.3 / .012	1.2 / .047	1.8 / .071	0.9 / .035
1.6 mm / .063 in.	0.8 / .031	1.55 / .061	1.6 / .063	2.3 / .091	2.8 / .110	0.4 / .016